

# **BUILDINGENERGY BOSTON**

---

**Operational and Embodied Carbon,  
Together at Last!**

**The MA 100-Home Embodied Carbon Study**

**Patrick Nachlas, Ekotrope**  
**Jacob Racusin, Builders for Climate Action**

*Curated by Megan Nedzinski and Tim Zumbo*

---

**Northeast Sustainable Energy Association (NESEA) | March 23, 2026**

# Hello!



Patrick Nachlas

Ekotrope

*Customer Success Manager for  
Raters and Providers*



Jacob Deva Racusin

Builders for  
Climate Action

*Senior Research and Innovation Advisor*

# How the Massachusetts 100 Home Embodied Carbon Study went beyond Energy

- ✓ About the Study
- ✓ Workflow by and for HERS Raters
- ✓ Embodied Carbon Results
- ✓ Blended Emission Results
- ✓ HERS Rater Experience
- ✓ What's Next

# GHG Emissions over the life cycle

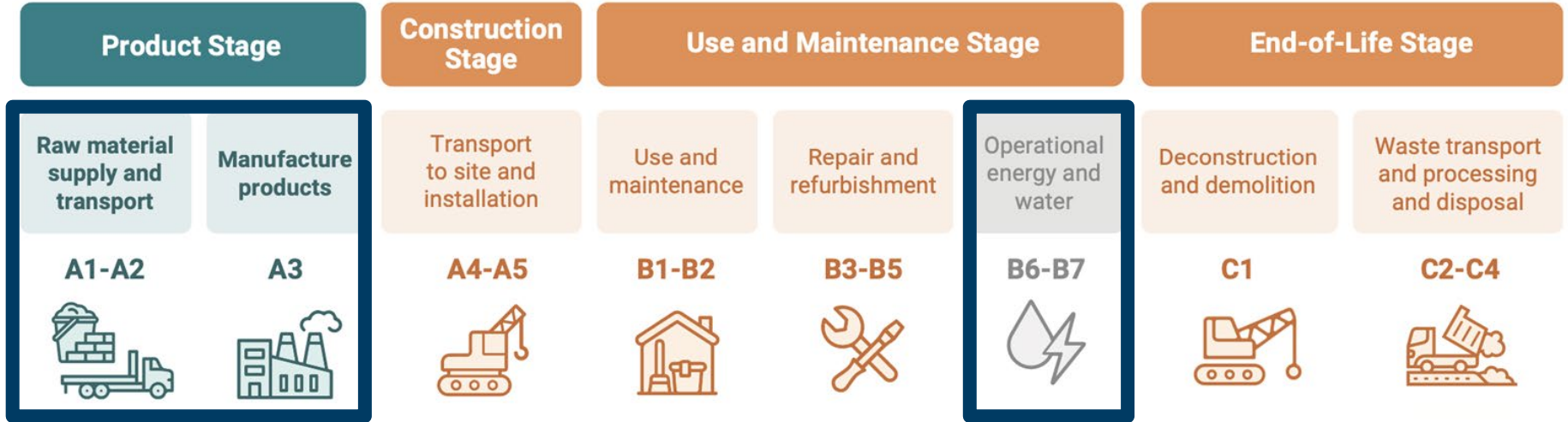

**Embodied Carbon is the emissions used to extract and manufacture building product materials (Stages A1-A3).**

# Global Impact of Building -Related Emissions

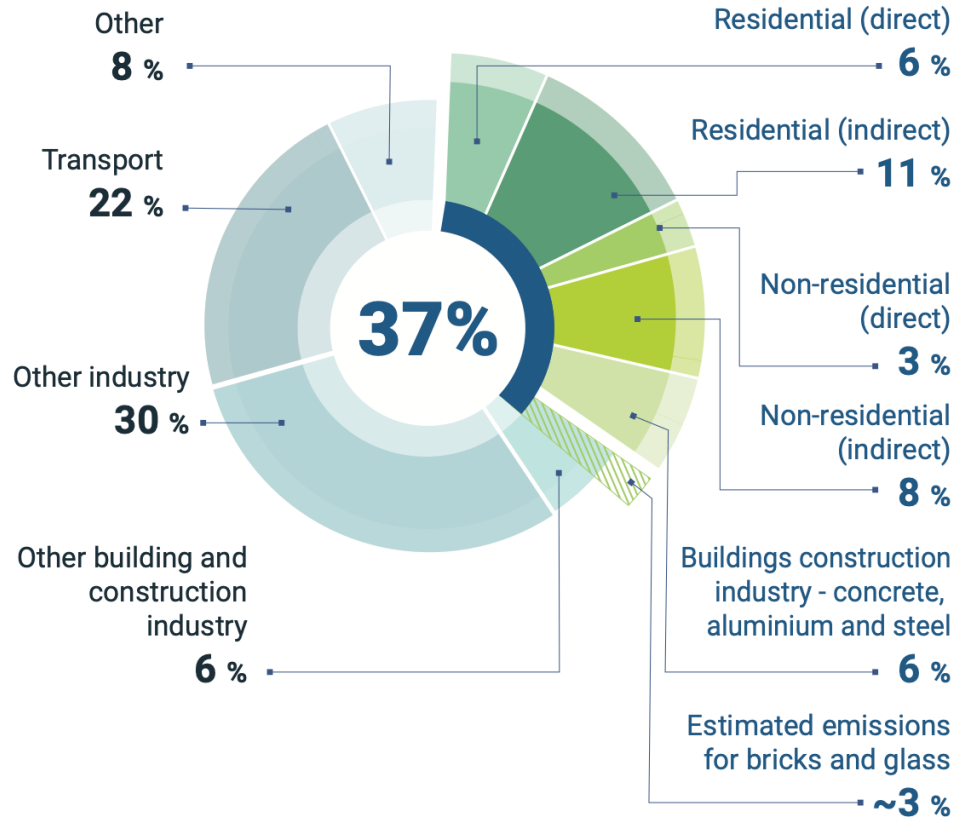

**Operational**  
carbon emissions  
28%

**Embodied**  
carbon emission  
9%  
+  
share of industry & transportation

# Operational Carbon Emissions - *Business as usual*

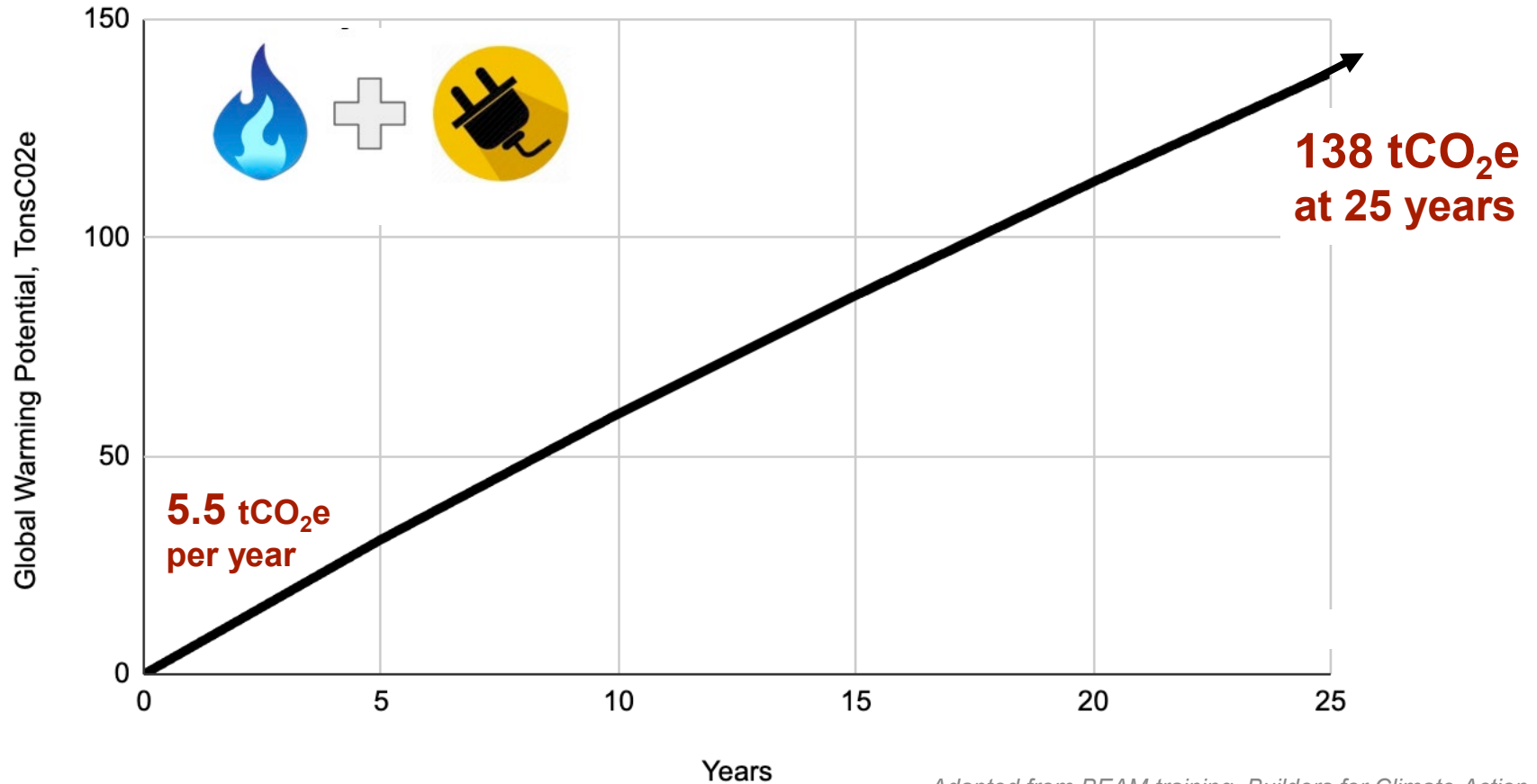

# Operational Carbon Emissions - *Business as usual*

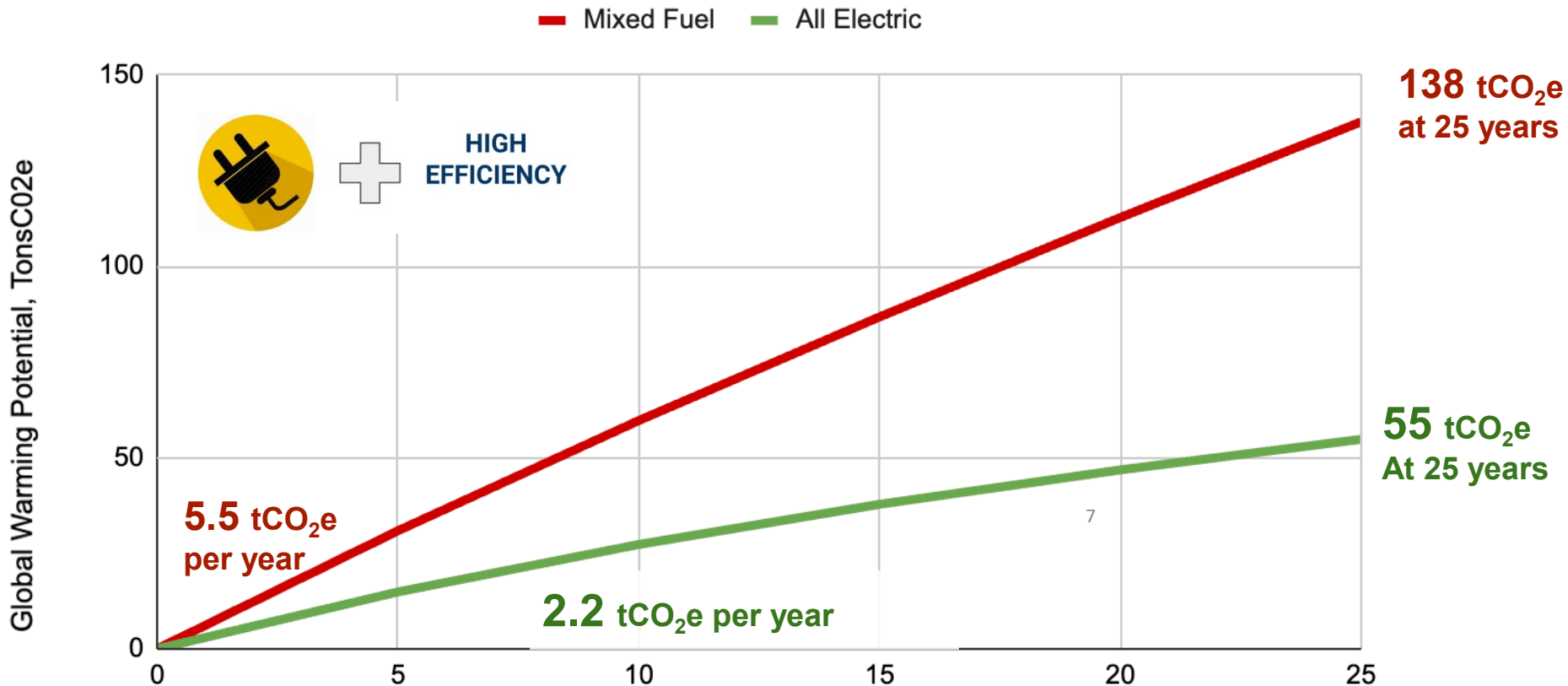

Measuring and reducing OC is well understood...

# But before operating emissions happen...

...there are up front emissions that need to be counted

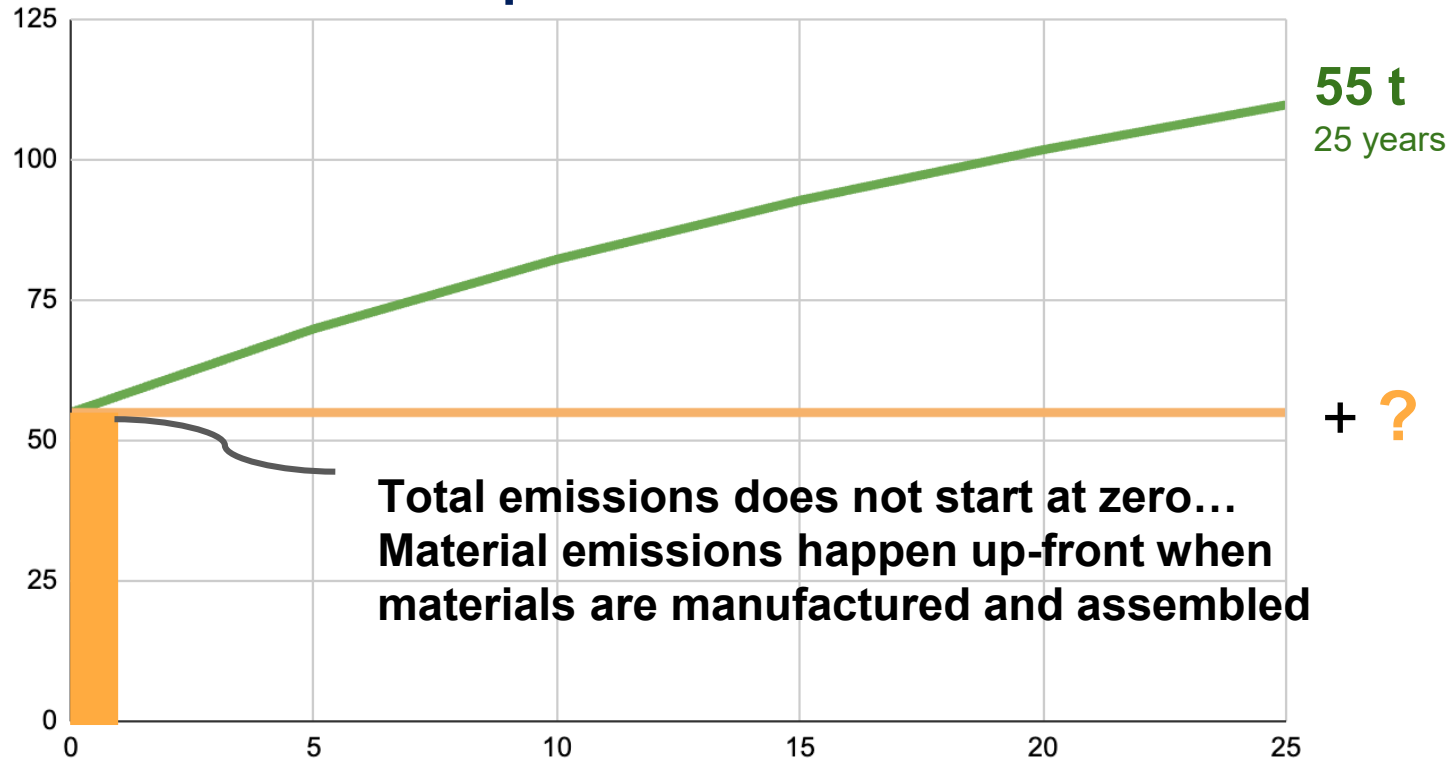

# Embodied Carbon Happens Up Front

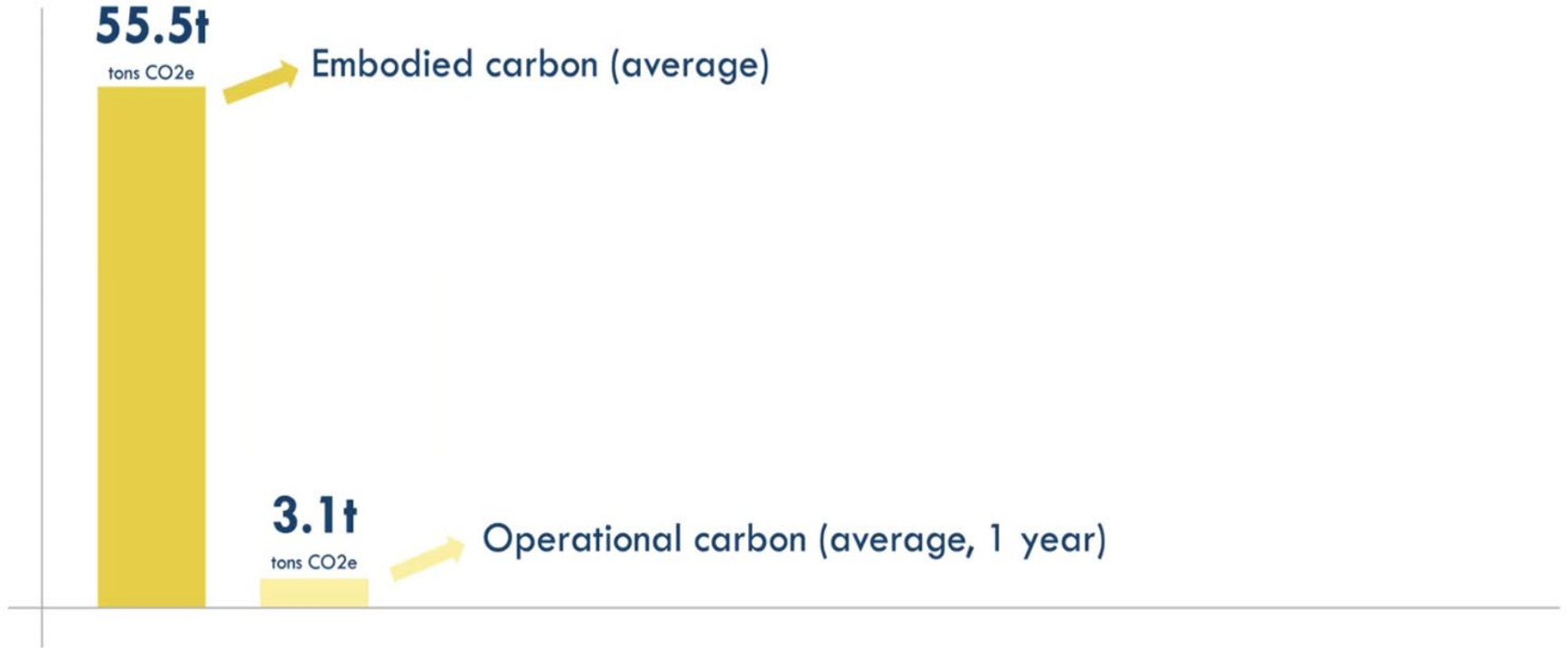

# Embodied Carbon Happens Up Front

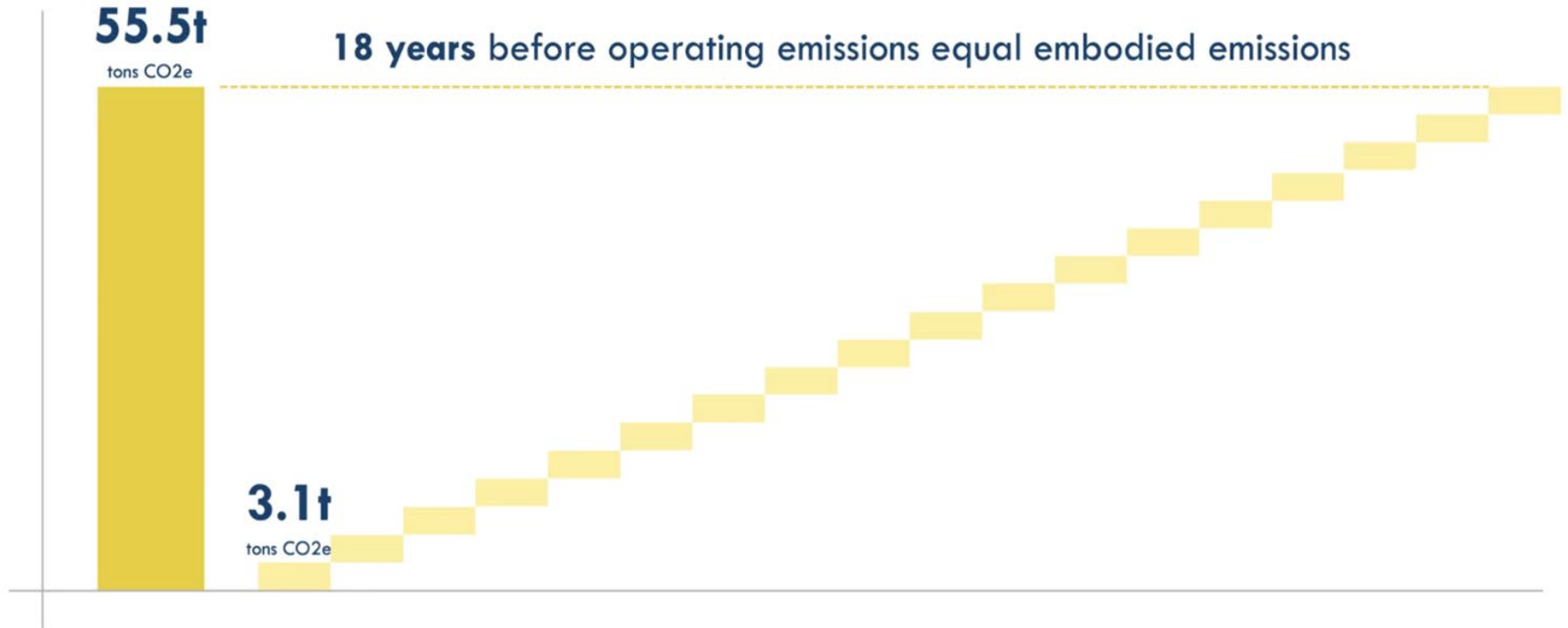

# Why should we care about embodied carbon?

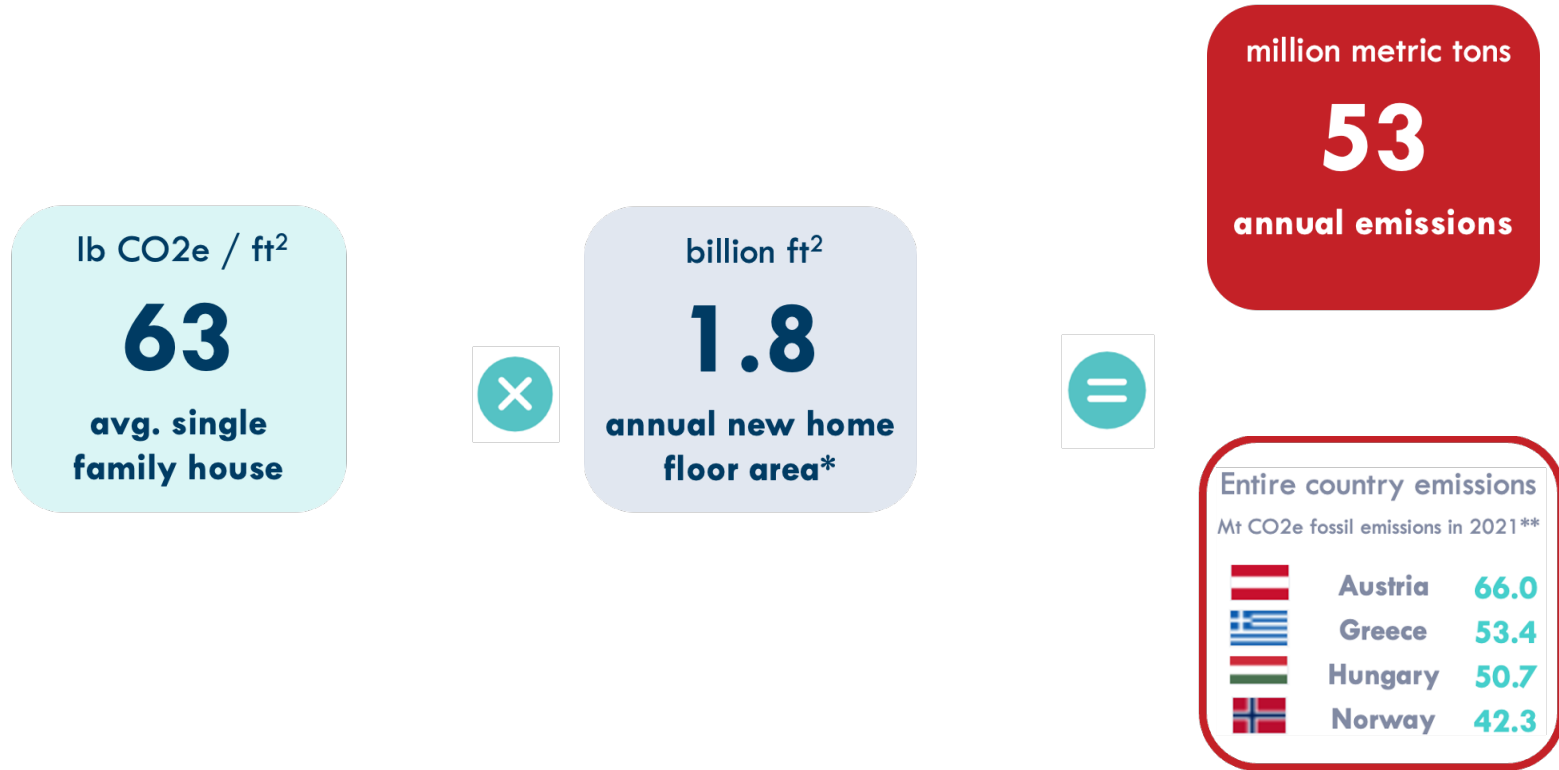

# Basic embodied carbon emission calculation

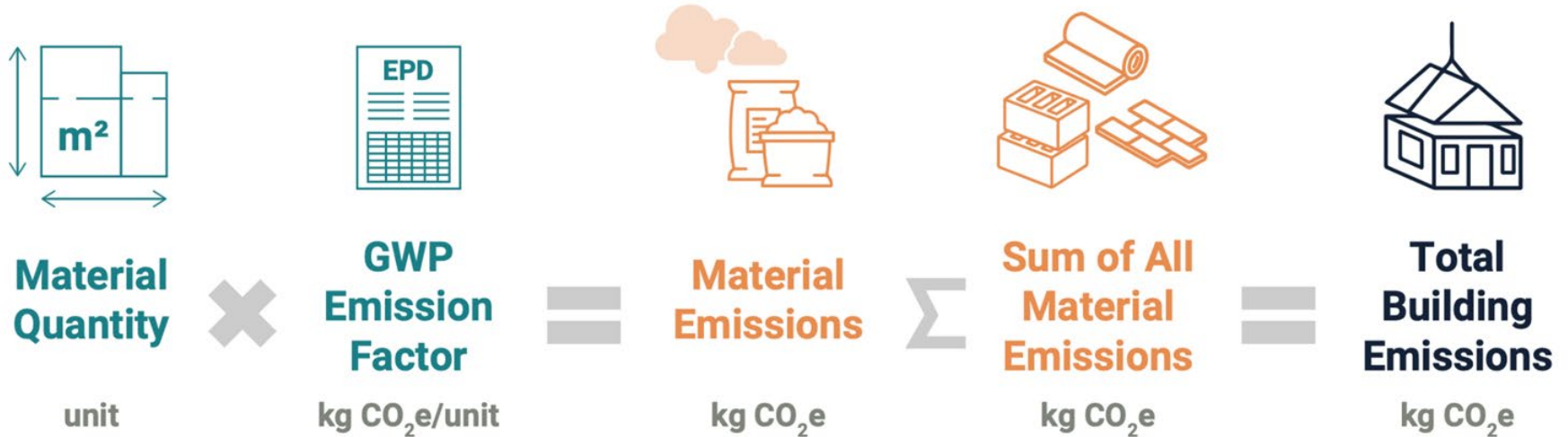

For Part 9, these typically come from area-based takeoffs.

Per life cycle module, from EPDs, LCAs, or generic databases

Per life cycle module

# EPD = Environmental Product Declarations

An EPD “*quantifies environmental information on the life cycle of a product to enable comparisons between products fulfilling the same function.*”

- *Like a nutritional label for material*
- Valid for 5 years and third party verified
- Follow standards (EN1508, ISO14040)
- GWP = kg CO<sub>2</sub> eq / functional unit

<b>Product Impacts</b>	
Declared Unit: 1 m <sup>3</sup> of 10,000 psi concrete at 28 days	
Amount Per Declared Unit	
<b>Global Warming Potential</b>	445 kgCO <sub>2</sub> eq
Emitted	460 kgCO <sub>2</sub> eq
Sequestered	-15 kgCO <sub>2</sub> eq
<b>Ozone Depletion</b>	0.000 kgCFC11eq
<b>Acidification</b>	2.96 kgSO <sub>2</sub> eq
<b>Eutrophication</b>	0.09 kgNeq
<b>Smog Formation</b>	0.61 kgO <sub>3</sub> eq
<b>Primary Energy Demand</b>	3017 MJ
Non-renewable	3000 MJ
Renewable	17 MJ

Image: Building Transparency  
<https://www.buildingtransparency.org/resources/how-get-epd/>



RMI – Energy.  
Transformed.

## Draft PDS-02 Standard RESNET C1550



Standard for  
Calculating and Reporting  
the Embodied Carbon of Buildings  
with Dwelling and Sleeping Units

# What is the Massachusetts 100 Home Study?

Why does it matter?



# 100 Homes Study

100 HERS Rated Homes in  
Massachusetts were selected for  
an Embodied Carbon assessment

## EC Baseline for MA

- Incentive structures
- Better lifecycle Carbon Reporting
- Helps low-EC material value proposition

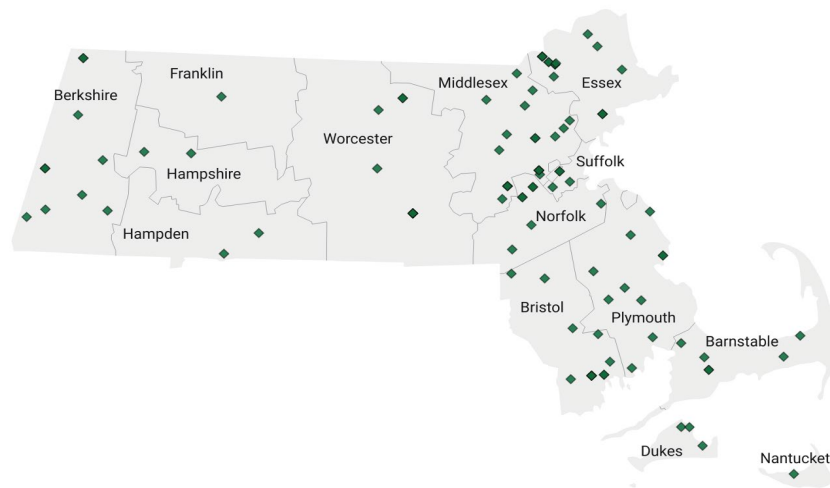

# 100 Homes Study

100 HERS Rated Homes in  
Massachusetts were selected for  
an Embodied Carbon assessment

## Rater Workflow

- Establish the Raters' role in EC reporting
- Understand effort to create EC model
- *Raters went through EC training and were subject to QA on all study projects*

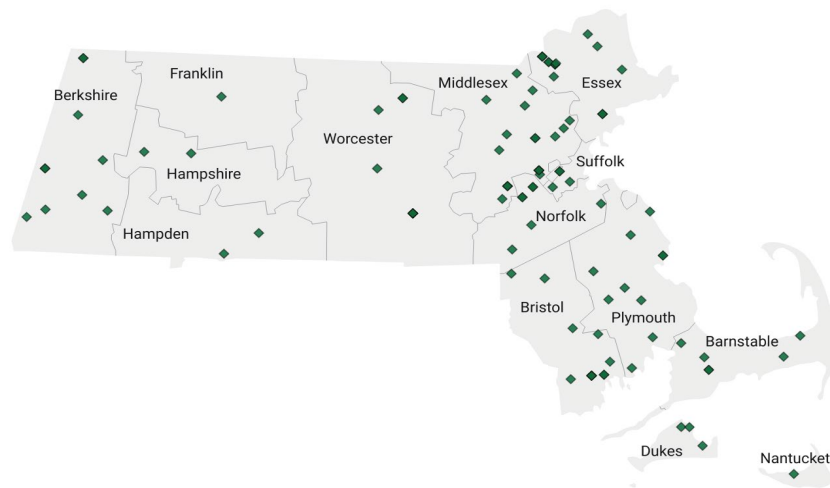

# The Funders

national**grid**



EVERSOURCE

# The Study Team



# What was unique about the 100 Homes Study?

- ✓ First EC study to include HERS Raters
- ✓ First N.A. EC benchmark study to include MEP in scope
- ✓ First study to show blend of HERS Index, Carbon Index, and Embodied Carbon
- ✓ Developed with Standard 1550

# Workflow Development

How was the study conducted?

# Basic embodied carbon emission calculation

Energy model

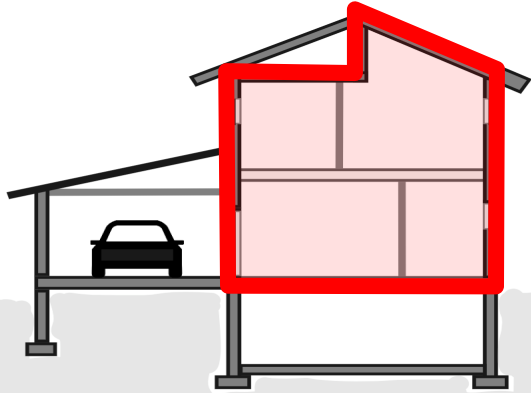

Thermal Envelope assemblies

MCE model

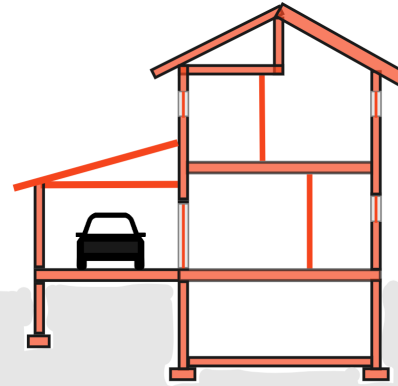

Whole Building  
Structure, Enclosure, and partition

# Life cycle stages included : A1 -A3 + B6

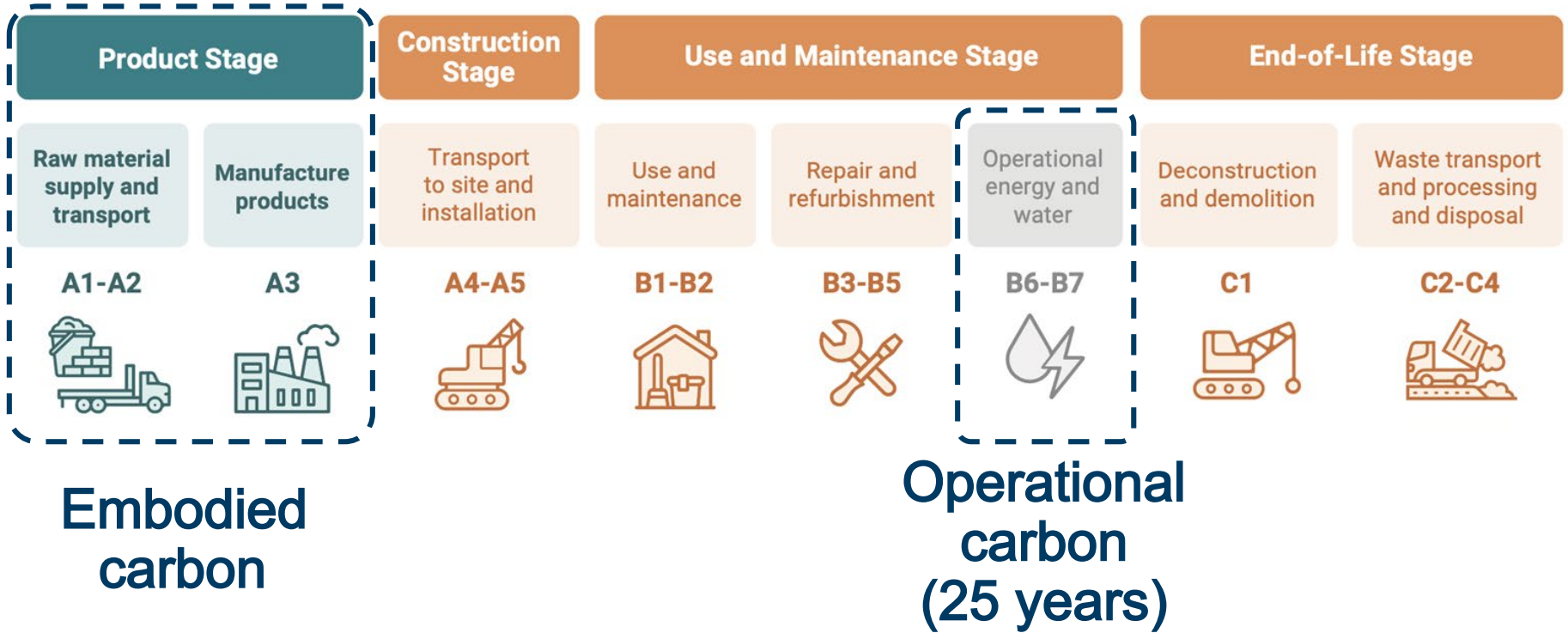

# Building Assemblies Included :

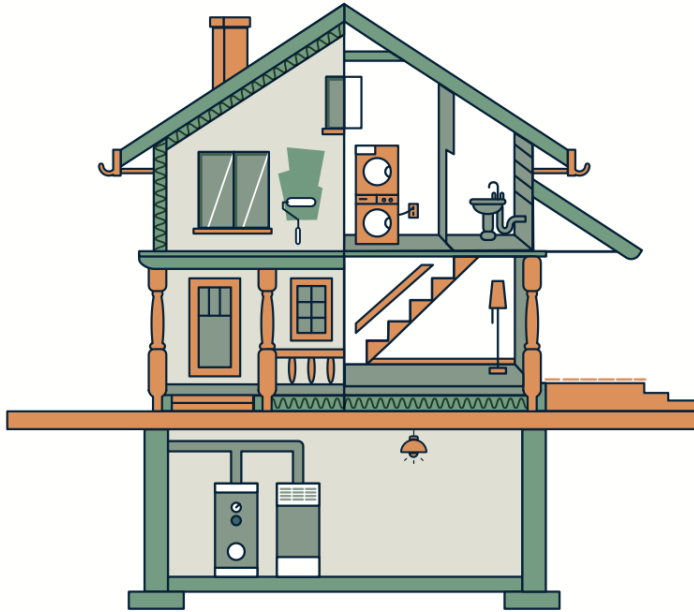

*Partially in Energy Model*

*Fully in Energy Model*

- Footings and slabs
- Foundation walls & insulation
- Exterior walls & insulation
- Party walls (where applicable)
- Exterior cladding
- Windows
- Ceilings & floors
- Roof (structure, insulation and roofing)
- Structural elements (posts & beams)
- Interior walls
- Garage
- Mechanical, Electrical, Plumbing (MEP) systems

# Study methodology overview

QA by research team

100 Registered  
Projects

Ekotrope  
Energy Model

Thermal Envelope  
Material

MEP

Drawings Set /  
Sketchup

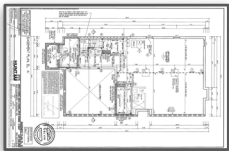

BETA Integration  
Worksheet

Material info imported  
from Ekotrope  
(dimension + type)

+

Manual inputs  
for missing information

MEP Embodied Carbon  
calculations

BEAM Model



CATEGORY	MATERIAL	QUANTITY	UNITS	%	SELECT	NET FLOORAREA	NET VOLUME	NET MASS
<b>CAVITY INSULATION</b>								
<b>WALL &amp; WALL CAVITY INSULATION</b>								
SPRAY FOAM INSULATION	Open Cell 200 gsm / R 6.0 inch / 150mm Polyurethane	2,000.00	sq ft	100%	<input type="checkbox"/>	12,075	12,075	0
SPRAY FOAM INSULATION	Open Cell 200 gsm / R 6.0 inch / 150mm Polyurethane	2,000.00	sq ft	100%	<input type="checkbox"/>	11,139	11,139	0
SPRAY FOAM INSULATION	Open Cell 200 gsm / R 6.0 inch / 150mm Polyurethane	2,000.00	sq ft	100%	<input type="checkbox"/>	2,651	2,651	0
SPRAY FOAM INSULATION	Open Cell 200 gsm / R 6.0 inch / 150mm Polyurethane	2,000.00	sq ft	100%	<input type="checkbox"/>	8,502	8,502	0
SPRAY FOAM INSULATION	Open Cell 200 gsm / R 6.0 inch / 150mm Polyurethane	2,000.00	sq ft	100%	<input type="checkbox"/>	2,906	2,906	0
<b>SPRAY FOAM INSULATION - CLOSED CELL</b>								
SPRAY FOAM INSULATION	Closed Cell 300 gsm / R 6.0 inch / 150mm Polyurethane	2,000.00	sq ft	100%	<input type="checkbox"/>	8,613	8,613	0
SPRAY FOAM INSULATION	Closed Cell 300 gsm / R 6.0 inch / 150mm Polyurethane	2,000.00	sq ft	100%	<input type="checkbox"/>	2,271	2,271	0
SPRAY FOAM INSULATION	Closed Cell 300 gsm / R 6.0 inch / 150mm Polyurethane	2,000.00	sq ft	100%	<input type="checkbox"/>	5,997	5,997	0
SPRAY FOAM INSULATION	Closed Cell 300 gsm / R 6.0 inch / 150mm Polyurethane	2,000.00	sq ft	100%	<input type="checkbox"/>	1,247	1,247	0
SPRAY FOAM INSULATION	Closed Cell 300 gsm / R 6.0 inch / 150mm Polyurethane	2,000.00	sq ft	100%	<input type="checkbox"/>	1,638	1,638	0
<b>SPRAY FOAM INSULATION - OPEN CELL</b>								
SPRAY FOAM INSULATION	Open Cell 200 gsm / R 6.0 inch / 150mm Polyurethane	2,000.00	sq ft	100%	<input type="checkbox"/>	929	929	0
SPRAY FOAM INSULATION	Open Cell 200 gsm / R 6.0 inch / 150mm Polyurethane	2,000.00	sq ft	100%	<input type="checkbox"/>	733	733	0
<b>IDENTIFICATION FOAM INSULATION</b>								
IDENTIFICATION FOAM INSULATION	Open Cell 200 gsm / R 6.0 inch / 150mm Polyurethane	2,000.00	sq ft	100%	<input type="checkbox"/>	1,042	1,042	0
IDENTIFICATION FOAM INSULATION	Open Cell 200 gsm / R 6.0 inch / 150mm Polyurethane	2,000.00	sq ft	100%	<input type="checkbox"/>	1,143	1,143	0
IDENTIFICATION FOAM INSULATION	Open Cell 200 gsm / R 6.0 inch / 150mm Polyurethane	2,000.00	sq ft	100%	<input type="checkbox"/>	1,116	1,116	0
IDENTIFICATION FOAM INSULATION	Open Cell 200 gsm / R 6.0 inch / 150mm Polyurethane	2,000.00	sq ft	100%	<input type="checkbox"/>	867	867	0
<b>MINERAL WOOL BATT INSULATION</b>								
MINERAL WOOL BATT INSULATION	Open Cell 200 gsm / R 6.0 inch / 150mm Polyurethane	400.00	sq ft	100%	<input type="checkbox"/>	392	392	0
MINERAL WOOL BATT INSULATION	Open Cell 200 gsm / R 6.0 inch / 150mm Polyurethane	2,000.00	sq ft	100%	<input type="checkbox"/>	1,244	1,244	0

# Main difference between Ekotrope and BEAM

Ex. : 2000 ft<sup>2</sup> of Exterior Wall

## Ekotrope

Wall A  
Area : 1600ft<sup>2</sup>

Fiberglass Batts R-20

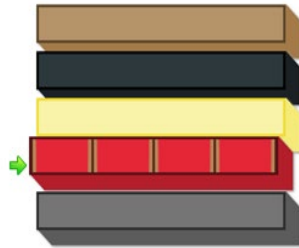

Wall B  
Area : 400ft<sup>2</sup>

Mineral wool Batts R-20

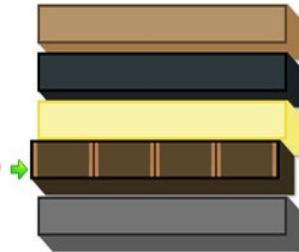

## BEAM

### Building Dimension Inputs (Excluding Garage)

DIMENSION NAME	QTY	UNIT	DESCRIPTION
EXTERIOR WALL AREA	2000.0	ft <sup>2</sup>	Surface area of exterior walls. Includes: gable ends. Excludes: window & door openings, party walls, garage

### EXTERIOR WALLS

PROJECT NAME: B-Collective - 3156\_22nd Ave  
SCENARIO: Baseline  
BEAM VERSION: V1.1

SECTION COMPLETE?

1,749

CATEGORY	MATERIAL	QUANTITY	UNITS	%	SELECT	NET EMISSIONS kg CO <sub>2</sub> e
		R-VALUE	20.0			
<b>CAVITY INSULATION</b>						
<b>FIBERGLASS BATT INSULATION</b>						
	Fiberglass batt / NAIMA / R 4.4-inch [Industry Avg   N.America]	1,600.0	ft <sup>2</sup>	80%	<input checked="" type="checkbox"/>	529
	Fiberglass batt / Johns Manville / Unfaced, ComfortTherm, Cavity-SHELD, FSK-237 / R 3.4-inch	2,000.0	ft <sup>2</sup>	100%	<input type="checkbox"/>	746
	Fiberglass batt / CertainTeed / Sustainable Insulation / R 3.6-inch	2,000.0	ft <sup>2</sup>	100%	<input type="checkbox"/>	615
	Fiberglass batt & roll / Owens Corning / Unfaced, PINK Next Gen Fiberglas / R 3.6-inch avg	2,000.0	ft <sup>2</sup>	100%	<input type="checkbox"/>	431
<b>MINERAL WOOL BATT INSULATION</b>						
	Mineral wool batt / [BEAM Avg]	400.0	ft <sup>2</sup>	20%	<input checked="" type="checkbox"/>	202
	Mineral wool batt / Owens Corning / UltraBatt - Fire & Sound Guard Plus R-13, R-30 (plant Avg) / R 4.2-inch	2,000.0	ft <sup>2</sup>	100%	<input type="checkbox"/>	1,244
	Mineral wool batt / Owens Corning / UltraBatt - Fire & Sound Guard Plus R-23 (plant Avg) / R 4.2-inch	2,000.0	ft <sup>2</sup>	100%	<input type="checkbox"/>	1,217
	Mineral wool batt / Rockwool / ComfortBatt R-24 (Wood Studs) / R 4.4-inch	2,000.0	ft <sup>2</sup>	100%	<input type="checkbox"/>	1,113
	Mineral wool batt / Owens Corning / UltraBatt - Fire & Sound Guard Plus R-10 (plant Avg) / R 4.0-inch	2,000.0	ft <sup>2</sup>	100%	<input type="checkbox"/>	1,106
	Mineral wool batt / Owens Corning / UltraBatt - Fire & Sound Guard Plus R-24 (plant Avg) / R 4.0-inch	2,000.0	ft <sup>2</sup>	100%	<input type="checkbox"/>	1,054

# Ekotrope Integration

*Ex. : 2000 ft<sup>2</sup> of Exterior Wall*

## Ekotrope

Wall A  
Area : 1600ft<sup>2</sup>

Fiberglass Batts R-20

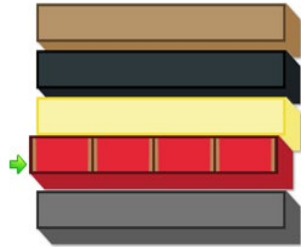

Wall B  
Area : 400ft<sup>2</sup>

Mineral wool Batts R-20

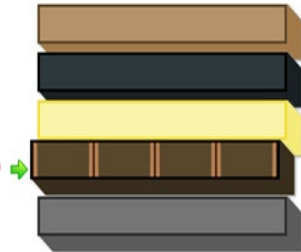

## Integration Worksheet

### DIMENSION

Total Exterior Wall Area : 2000 ft<sup>2</sup>

### Exterior Wall Breakdown

Category	Type	Area	%	Add. Factors
Cladding	Siding (wood)	2000	100%	
Membrane	Sheet Barrier	2000	100%	
Sheathing	OSB ½"	2000	100%	
Cavity Insulation	Fiberglass Batt	1600	80%	R-value : 20
	Mineral Wool Batt	400	20%	R-value: 20
Framing	Wood 2x6	2000	100%	
Interior Cladding	Gypsum	2000	100%	

# STEP 2.1 - Foundations / Foundation walls

## Foundation walls Area

Total foundation wall surface area (center-line length x height)

Include: basement, party walls.

Exclude: openings, garage foundation

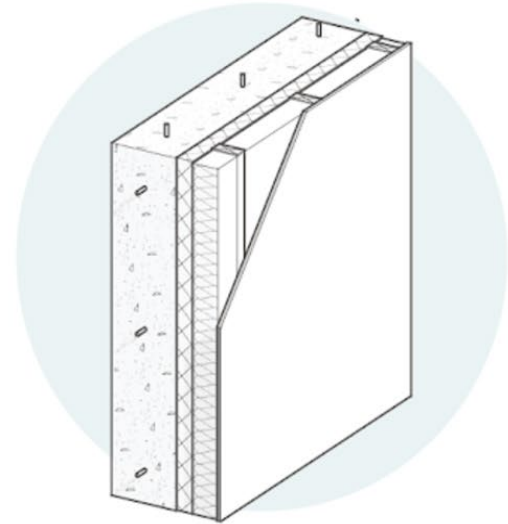
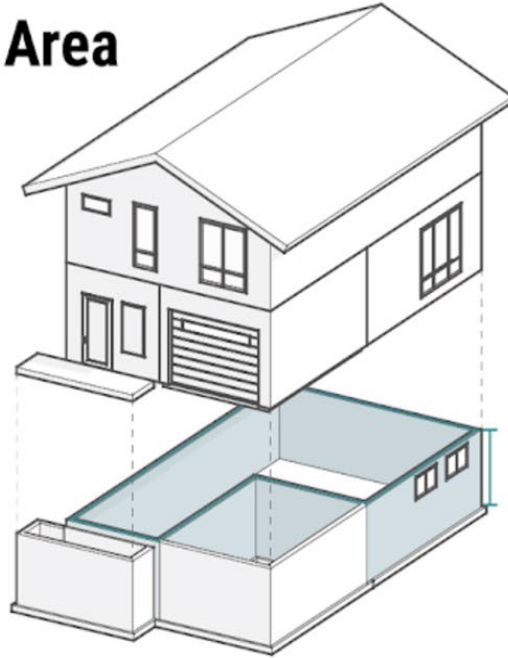

# Ekotrope input for Walls

Detailed inputs for insulation values, but no input for wall thickness or unconditioned basements.

### Foundation Wall

Help

Name   Verified

R Value 301-2022:   
R Value 301-2019:

Continuous Insulation  Has Stud/Cavity Layer?

R-value <input type="text" value="15"/>	Material <input type="text" value="Fiberglass Batts"/>	Stud Type <input type="text" value="Wood"/>
Fully insulated (top to bottom) <input checked="" type="checkbox"/>	Depth in. <input type="text" value="3.5"/>	Depth in. <input type="text" value="3.5"/>
	Insulation Grade <input type="text" value="I"/>	Width in. <input type="text" value="1.5"/>
	Per Inch <input type="radio"/> Total <input checked="" type="radio"/>	Spacing in. <input type="text" value="16"/>
	R <input type="text" value="13"/>	Framing Fraction <input type="text" value="0.250625"/>
		<input type="checkbox"/> Override Framing Fraction <input type="text" value="0.5"/>
		Sheetrock Thickness [in] <input type="text" value="0.5"/>

### Foundation Wall

Name

Type

Height Above Grade [ft]

Depth Below Grade [ft]

Exterior Perimeter [ft]

Encloses

Between interior and

## STEP 2.1 - Foundations / Foundation walls

\*Foundation walls enclosing condition space are integrated from Ekotrope

\*Rater need to input foundation wall area (ft<sup>2</sup>) enclosing unconditioned space. Exclude windows area.

\*Rater need to confirm wall thickness (in)

### ✓ FOUNDATION WALLS

#### Dimensions

	Area (ft <sup>2</sup> )	Perimeter (ft)	Thickness (in)
Encloses Conditioned Space	1700	175	8
Encloses Conditioned Crawlspace	0	0	8
Encloses Unconditioned Space	0	0	8
<b>TOTAL AREA</b>	<b>1700</b>		<b>8</b>

# Measuring Embodied Carbon for MEPs

Brand new default data from Standard 1550!

NO LIFT FOR RATERS!

□ Mechanical		Subtotal :	5768 Kg CO2e
<b>Heating and Cooling Equipment</b>			
Natural Gas Furnace	Equip capacity :	0 kBtu capacity	0
Ducted Heat Pump + Compressor	Equip capacity :	5 tons	3420
Mini-Split Heads + Compressor	Equip capacity :	1 tons	720
Central A/C Compressor	Equip capacity :	0 tons	0
Electric Aux Heater	Equip capacity :	0 kBtu capacity	0
Electric Baseboard	Equip capacity :	0 kBtu capacity	0
Gas boiler	Equip capacity :	0 kBtu capacity	0
Air-to-water heat pump	Equip capacity :	0 tons	0
Ground source heat pump equipment	Equip capacity :	0 tons	0
Ground source heat pump ground loop borehole	Li. feet of borehole :	0 linear foot	0
<b>Other Equipment</b>			
Fan coil	Equip capacity :	0 tons	0
Exhaust Fan (e.g. bath, range hood)	Number of Fan :	0 unit	0
Balanced ventilation with energy recovery	Number of units :	1 unit	350
Pump, small (e.g. circulator)	Number of small pump :	0 unit	0
Pump, large (e.g. sump, booster)	Number of large pump :	0 unit	0
<b>Distribution</b>			
Ductwork heating and cooling	Duct area, sq ft	380 sq ft of duct	912
Ductwork heating and cooling insulation	Duct area, sq ft	0 sq ft of duct	0
Ventilation supply distribution ductwork is shared with heating/cooling distribution		<input type="checkbox"/>	
Ventilation return distribution ductwork is shared with heating/cooling distribution		<input type="checkbox"/>	
Ductwork ventilation	Duct area, sq ft	152 sq ft of duct	365
Ductwork ventilation insulation	Duct area, sq ft	8 sq ft of duct	1
Hydronic radiant distribution	Sq ft radiant surface :	0 sq ft	0
Hydronic baseboard	Equip capacity :	0 kBtu	0

# Measuring Embodied Carbon for MEPs

- H/C capacity
- Fans/pumps count
- Ductwork length
- Wiring area
- Fixtures count

## Heating and Cooling Equipment

Natural Gas Furnace	Equip capacity :	0 kBtu capacity
Ducted Heat Pump + Compressor	Equip capacity :	5 tons

## Other Equipment

Fan coil	Equip capacity :	0 tons
Exhaust Fan (e.g. bath, range hood)	Number of Fan :	0 unit
Balanced ventilation with energy recovery	Number of units:	1 unit
Pump, small (e.g. circulator)	Number of small pump :	0 unit
Pump, large (e.g. sump, booster)	Number of large pump :	0 unit

## Distribution

Ductwork heating and cooling	Duct area, sq ft	380 sq ft of duct
Ductwork heating and cooling insulation	Duct area, sq ft	0 sq ft of duct
Ventilation supply distribution ductwork is shared with heating/cooling distribution	<input type="checkbox"/>	
Ventilation return distribution ductwork is shared with heating/cooling distribution	<input type="checkbox"/>	
Ductwork ventilation	Duct area, sq ft	152 sq ft of duct
Ductwork ventilation insulation	Duct area, sq ft	8 sq ft of duct
Hydronic radiant distribution	Sq ft radiant surface :	0 sq ft
Hydronic baseboard	Equip capacity :	0 kBtu

Calculates directly from  
HERS Raters Minimum Rated Features

# Embodied Carbon Results

What did we learn?

# Embodied carbon emissions (Tons of CO<sub>2</sub>e)

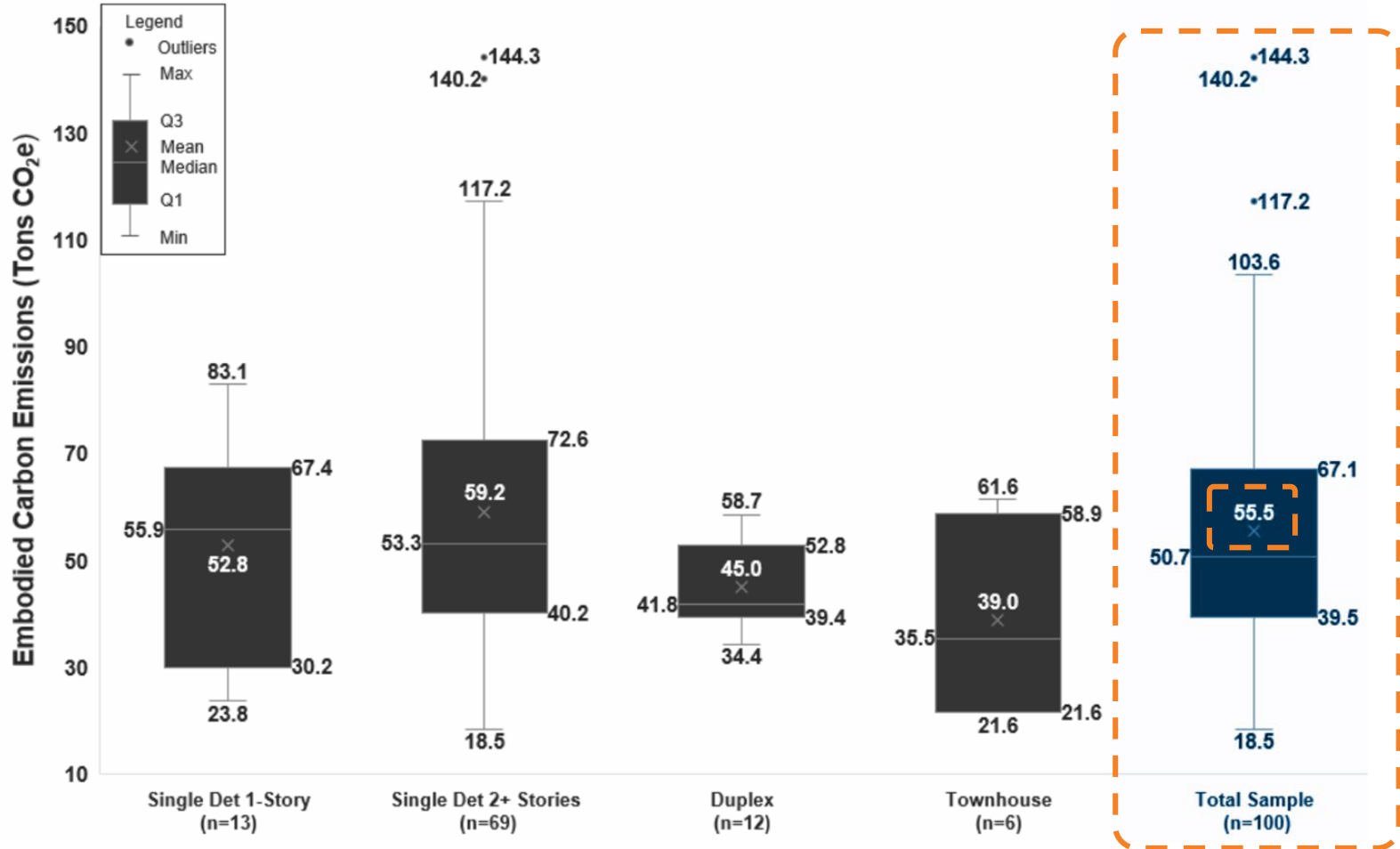

# What about when normalized for home size?

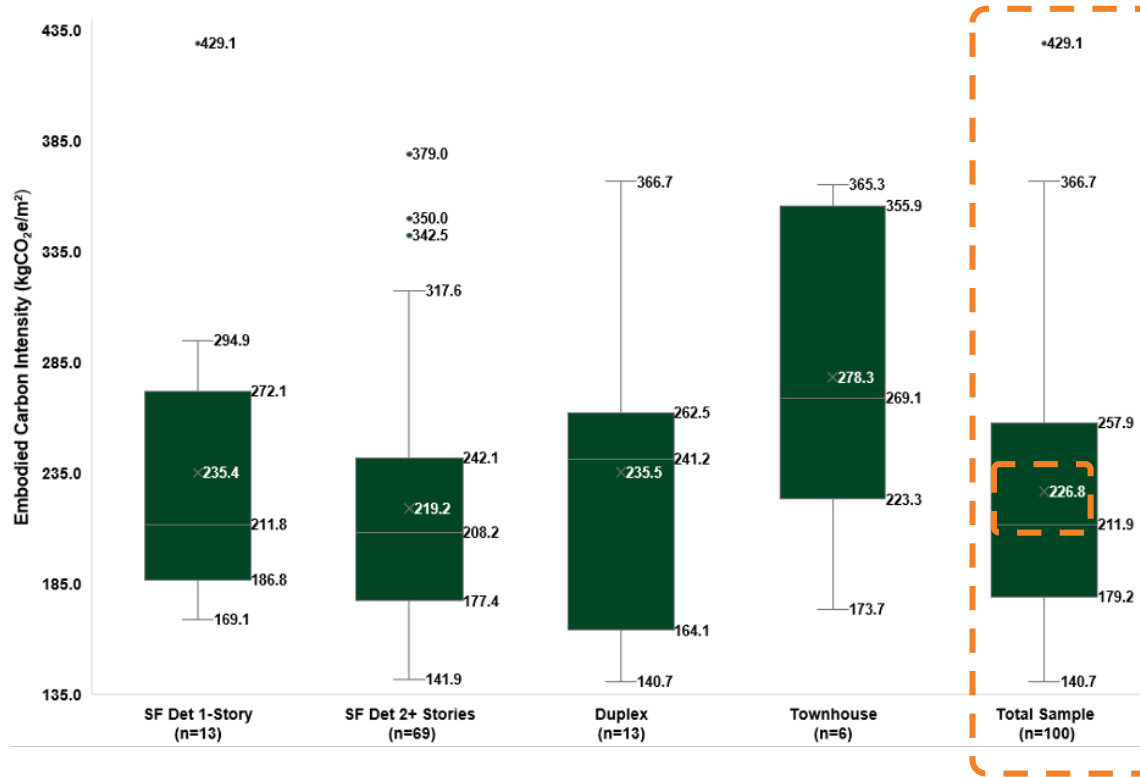

Net ECI per Conditioned Floor Area by Home Type (kg CO<sub>2</sub>e/m<sup>2</sup>)

# Results are similar to other studies (kg CO<sub>2</sub>e/m<sup>2</sup>)

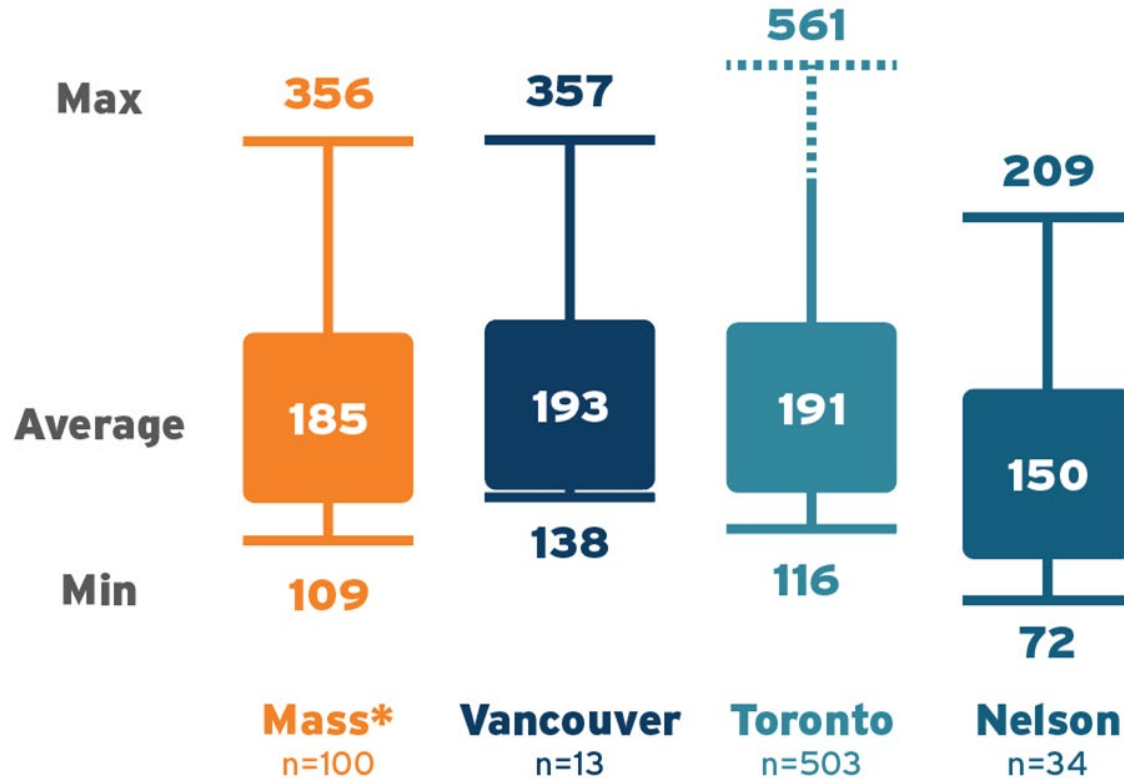

# What areas of the home contributed the most?

Gross Material Emissions by Category (% contribution of total)

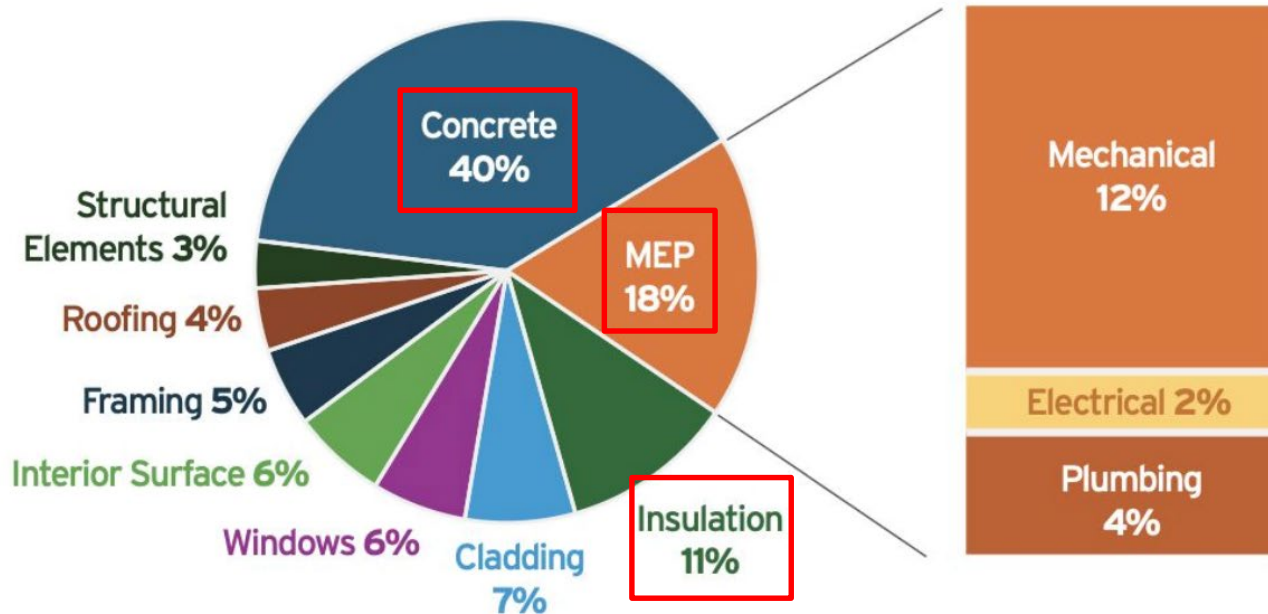

# Let's Blend

## Combining Operational and Embodied Carbon



# What about operational emissions?

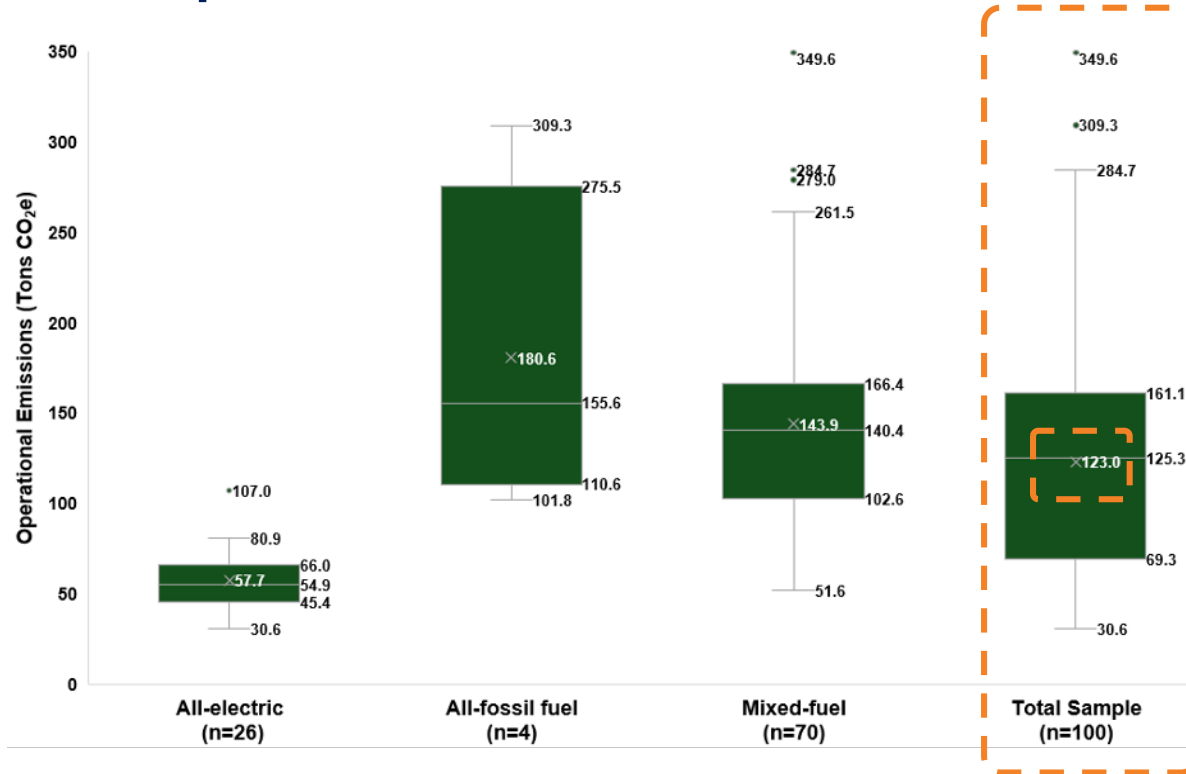

25-year Forecast of Cumulative Operational Carbon Emissions  
by Fossil Fuel Use (Tons CO<sub>2</sub>e)

# Embodied emissions are significant

ECE is average 32% of total emissions over 25 years

**118 tons CO<sub>2</sub>e:**  
Operational emissions  
over 25 years

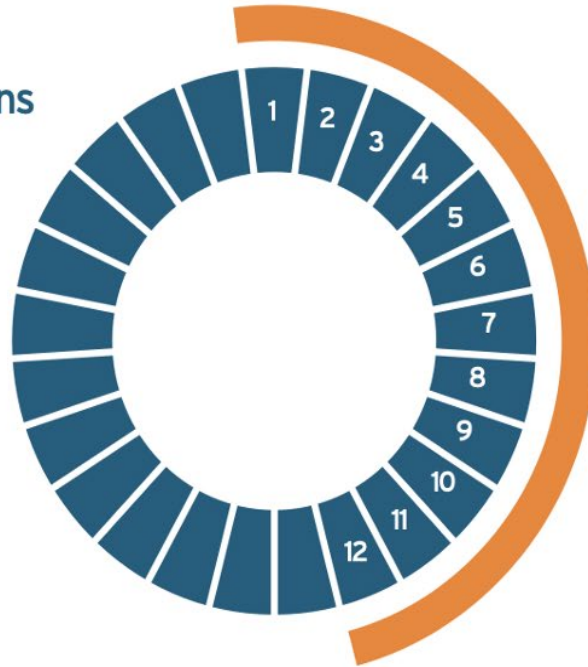

**56 tons CO<sub>2</sub>e:**  
Embodied emissions  
equates to 12 years of  
operational emissions



# Results: ECE and energy efficiency

Net Embodied Carbon Intensities per Conditioned Floor Area by HERS® Index (kg CO<sub>2</sub>e/m<sup>2</sup>)

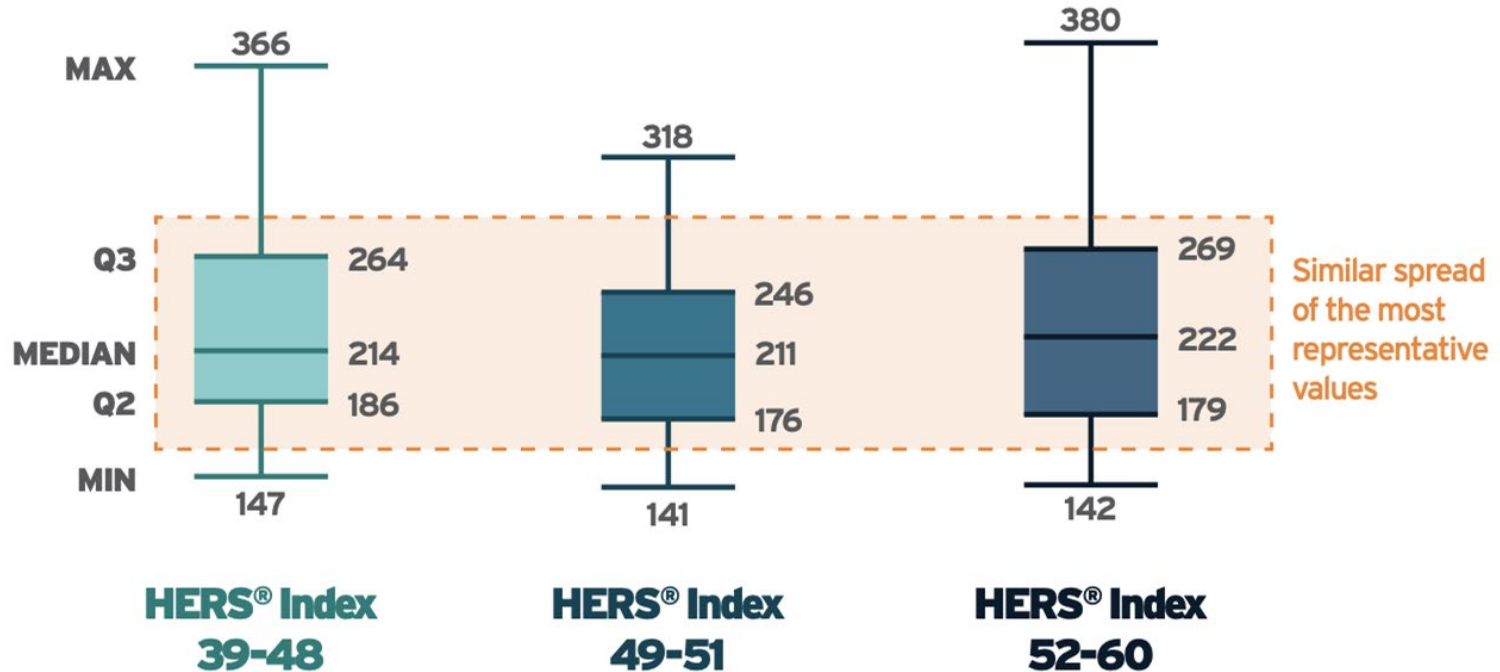

# Results: The level of energy efficiency is not a predictor of embodied carbon performance.

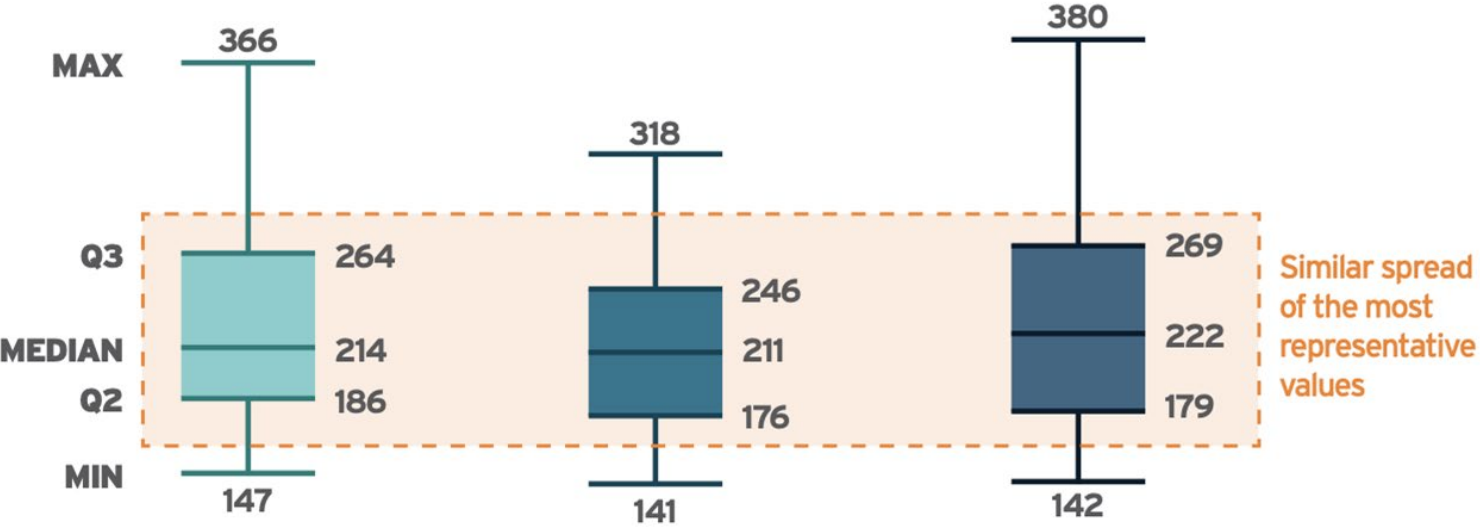

More efficient → Less efficient

# Results: BOTH material and fuel choices matter!

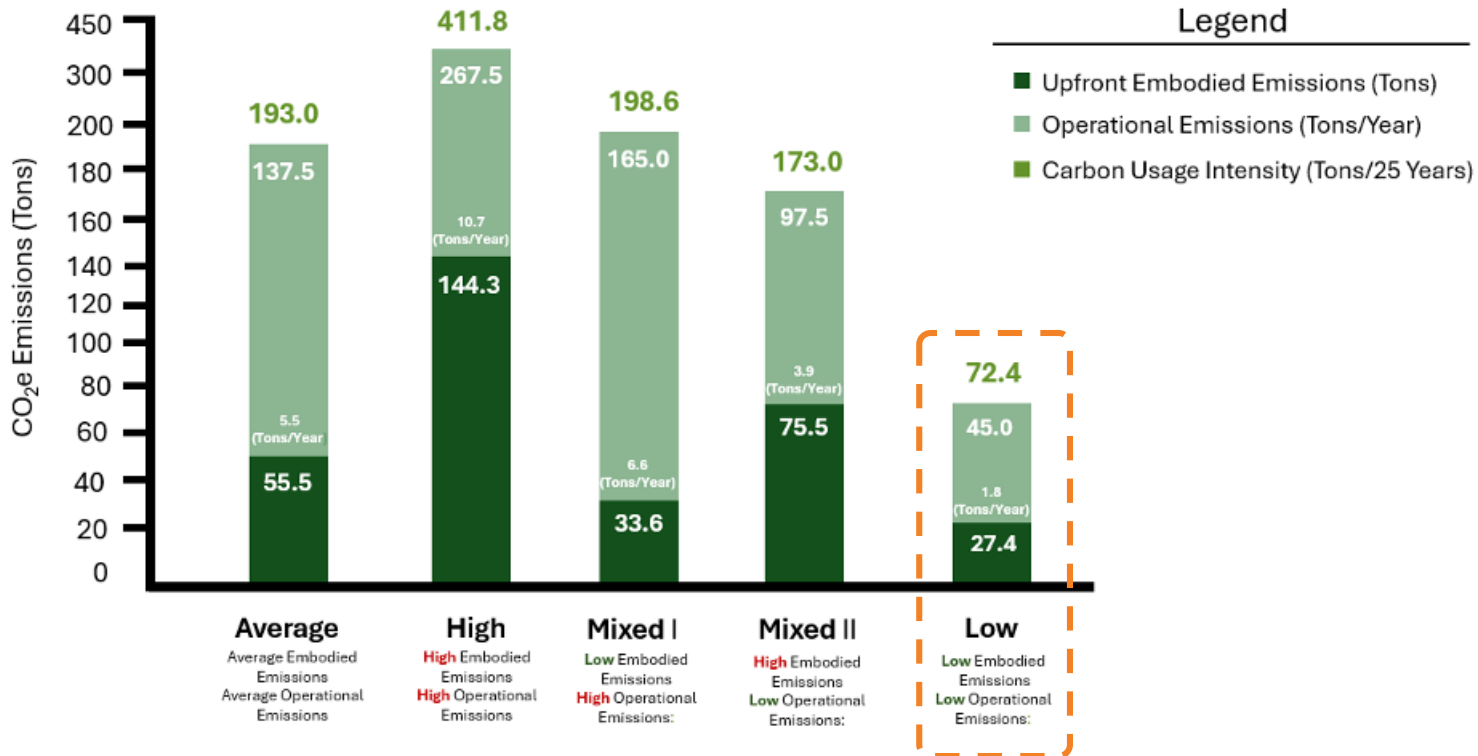

# “Yes and” approach to ECE and OCE

Operational Performance Improvement	Possible to Achieve with Equivalent or Reduced Embodied GHGe
Reduced building size and/or surface area	✓
Increased quantity of insulation	✓
High performance windows	✓
Improved air tightness	✓
Improved equipment efficiency	✓
Fuel switching	✓
Passive design	✓

What did the Raters think?

How big a pain in the butt was this?

# How long did modeling these homes take?

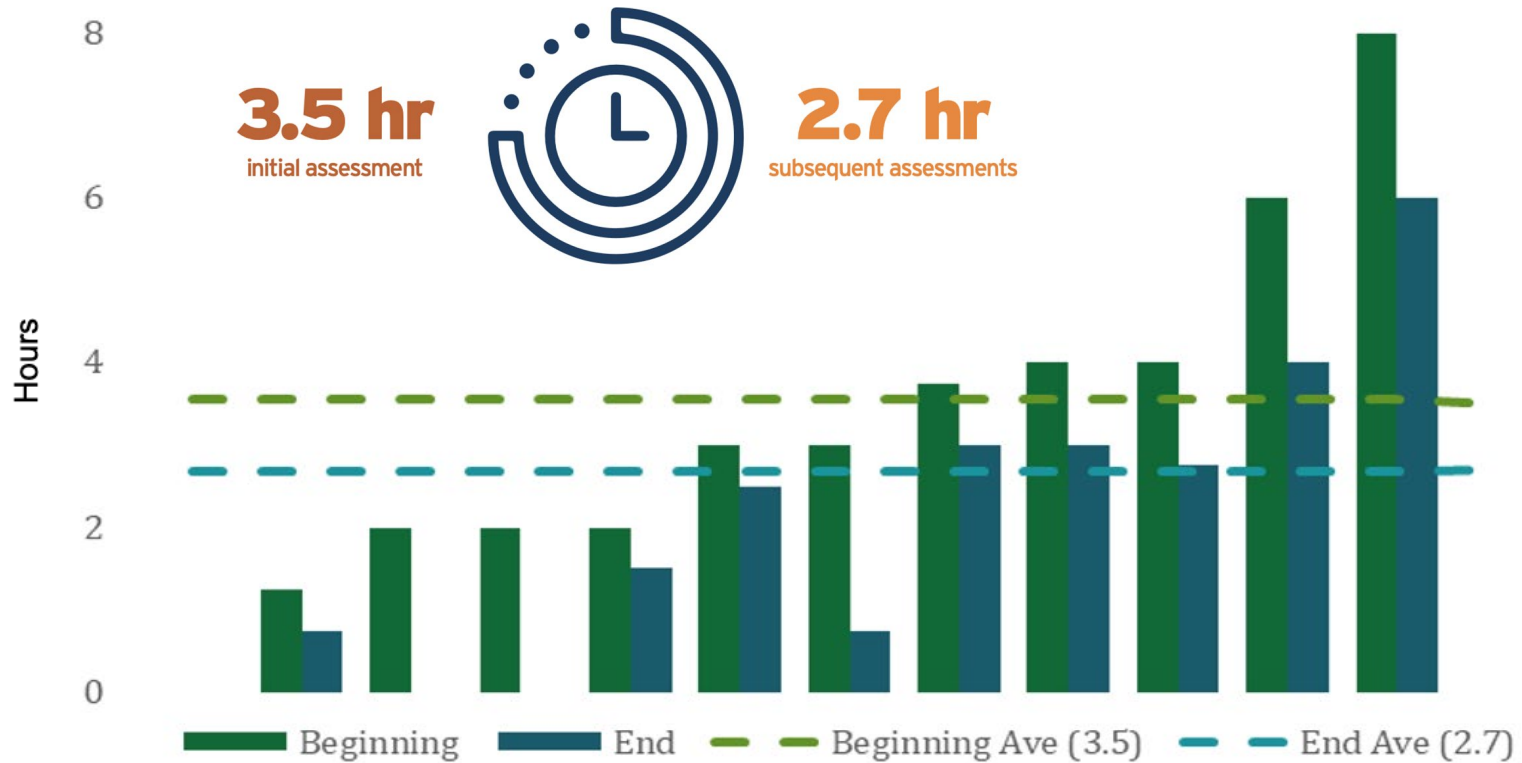

Respondent Reduction in Respondent Time to Complete Embodied Carbon Assessment

# HERS Raters & EC Assessments

Key gaps, training needs, and preferred delivery formats identified by HERS raters



## Gaps in Understanding

Embodied Carbon

**55%** Identifying specific Products from drawings

**27%** Guidance on level of details needed

**18%** Struggled with assessing structure



## Recommended Training

Priority Areas

Reading Plans & Doing Take-offs



General Construction Knowledge



Embodied Carbon Fundamentals



## Delivery Formats

Preferred Methods

- Visual & Video Guides
- Webinars
- Email Updates
- Peer Collaboration

# Market Transformation

A coordinated body of work to support the equitable scaling of actions needed



## Standards and Codes

### RESNET C1550

A standardized framework ensuring fair and inclusive implementation across the industry.



## Technology

### INNOVATION & TOOLS

Tool integration with a tested workflow, driving efficiency through innovation currently underway.



## Workforce Development

### ACTIONABLE INSIGHTS

The study provided real insight into workforce needs, supporting targeted skills development and training.

Now what?

How can this be applied?

# Embodied carbon in the MA stretch code

Pursuing the Embodied Carbon Credit grants you 3 HERS points lenience on energy code compliance.

**TABLE R406.5 MAXIMUM ENERGY RATING INDEX**

	Maximum HERS Index score <sup>a,b</sup>			
	New construction permits after July 1, 2024	New Construction with R406.5.2 embodied carbon credit	Accessory Dwelling Units	Major alterations, additions, or change of use <sup>c</sup>

<i>Mixed-Fuel Building</i>	42	45	52	65
Solar Electric Generation	42	45	55	70
<i>All-Electric Building</i>	45	48	55	70
Solar Electric & <i>All-Electric Building</i>	45	48	58	75

# Embodied carbon in the MA stretch code

Pursuing the Embodied  
Carbon Credit grants  
you 3 HERS points  
lenience on energy  
code compliance.

1. **Insulation embodied carbon credit:** new single *dwelling units* or R-use buildings containing multiple *dwelling units* that demonstrate an average calculated insulation Global Warming Potential (GWP) intensity ( $\text{kg CO}_2\text{e}/\text{m}^2$ ) less than 0 across the whole building envelope shall offset 3 HERS points for each applicable *dwelling unit* of new construction. GWP intensity shall be based on the default values in Table R406.5.3, or product specific EPDs or calculations in the approved tools: EC3 and BEAM, may be used in place of default table values.
2. **Low GWP concrete mix credit:** new single *dwelling units* or R-use buildings containing multiple *dwelling units* that demonstrate an average calculated concrete mix Global Warming Potential (GWP) for at least 90% of all concrete mix used in the building of not

# Current Implementation in Ekotrope

Only available for projects in  
Massachusetts.

Automation and workflow can still be  
improved.

Embodied Carbon Credits

i Yes

Insulation Embodied Carbon Credit Calculated GWP

i

Low GWP Concrete Mix Credit Calculated GWP

i

# Concrete emission reduction

- ✓ Reduce massing
- ✓ Optimize required strength
- ✓ Optimize formulations  
(additives, Type 1L)
- ✓ Spec lowest %GWP reduction  
(work with GC, SE, ready-mix)
- ✓ Emerging tech:  
biochar, pozzolans
- ✓ Novel tech: Sublime Systems,  
Prometheus Materials



# Drop-in replacements for insulation

Select low-carbon insulation materials for the same performance (often better value!)



# TIMBERHP

INSULATE BETTER. LIVE BETTER.™

TimberBatt	TimberFill	TimberBoard
<p>Acoustic &amp; Thermal Cavity Insulation</p>  <p>EXPLORE TIMBERBATT &gt;</p>	<p>Dense Pack &amp; Blanket Insulation</p>  <p>EXPLORE TIMBERFILL &gt;</p>	<p>Exterior Continuous Insulation</p>  <p>EXPLORE TIMBERBOARD &gt;</p>

# Other Opportunities

Embodied Carbon has gone this far with no code requirements. It can keep growing.

- ✓ Builders with sustainability goals tied to emissions reduction
- ✓ Utility companies with CO<sub>2</sub>e reduction requirements
- ✓ Jurisdictions with climate goals (VT, MA, CA, OR)
- ✓ Green building programs (e.g. Living Futures)

# Bottom Line

What do we need to take away?

1. You must consider operational and embodied emissions **TOGETHER** to reach decarbonization goals
2. HERS Raters can make this happen through measurement and recommendations
3. Standard 1550, BEAM development, industry support will help
4. Focus on the big things: concrete, insulation, MEP

THANK YOU

# Resources

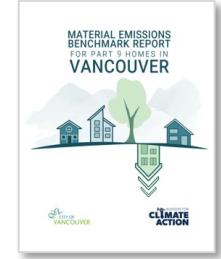
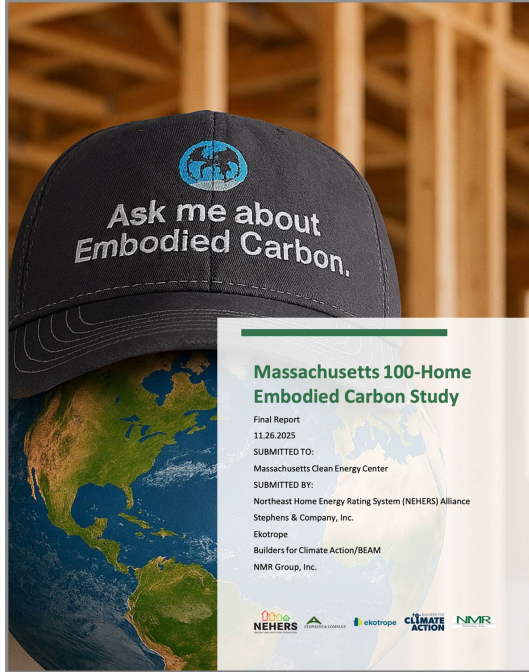

<https://www.buildersforclimateaction.org/our-work.html>

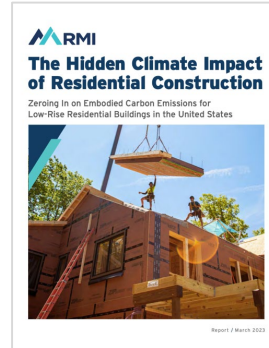

<https://rmi.org/homebuilderscan/>

# BUILDINGENERGY BOSTON

---

Please fill out an evaluation for this session



or: [nesea.org/eval](https://nesea.org/eval)

---

Northeast Sustainable Energy Association (NESEA)