

# **BUILDINGENERGY BOSTON**

---

## **Closing the Materials Gap: Practical Steps for Making Better Materials Choices**

**Kena David, Consigli Construction**

**Andrea Love, Payette**

**Misha SemeLev, Yale University**

**Charley Stevenson, Materially Better**

*Curated by Ted Butler and Brenda Lam*

---

**Northeast Sustainable Energy Association (NESEA) | March 24, 2026**

# Learning Objectives

1. **Identify** typical material improvement obstacles and best practices
2. **Classify the five impact categories** under the Mindful Materials Common Materials Framework.
3. **Evaluate solutions** used by different project team members to drive success in the final outcomes.
4. **Explain the role of AI-enabled tools** in supporting materials work.

An architectural rendering of a modern building at dusk. The building features a large glass facade and a prominent white tower with a dome in the background. The scene is framed by trees with vibrant autumn foliage in shades of orange, red, and yellow. The sky is a deep blue with a crescent moon. In the foreground, there are several people walking on a path, and a few benches are visible. The overall atmosphere is serene and modern.

# Owner's Perspective

# Yale's Capital Program Ambitions



# Current Piecemeal Standards from the 2010s

	Title: YALE OFFICE OF FACILITIES PROCEDURE MANUAL Chapter: 01 - Yale Design Standard Division: 01 35 63 Sustainable Design	Section: 01 35 63 Requirements for Sustainable Design
		Date: June 2025
		Author: Office of Facilities

LEED BD+C and LEED ID+C: Must incorporate Building Product Disclosure and Optimization – Material Ingredients Credit, Option 1 Material Ingredient Reporting. Yale further requires that product disclosures meeting this credit shall be Declare Living Building Challenge (LBC) Red List Free or Red List Approved at the time of specification.

Yale University requires reporting on embodied carbon on all comprehensive scope projects. Provide an embodied carbon analysis as an attachment to the basis of design at the Final Submission. Modeling and analysis tools to be determined with the Yale Project Manager.

## Materials and Products Standards

Designers shall provide product and materials specifications that preferentially select resource, energy saving and healthy building materials and design features.

## SUSTAINABLE PRODUCTS LIST YALE UNIVERSITY

16 March 2012



# (Imperfect) Verification via LEED V4

MATERIALS AND RESOURCES	9 OF 13
Storage and Collection of Recyclables	Y
Construction and Demolition Waste Mgmt Planning	Y
Building Life-Cycle Impact Reduction	5 / 5
Product disclosure & optimization - Environmental Product Declarations	2 / 2
Product disclosure & optimization - Sourcing of Raw Materials	0 / 2
Product disclosure & optimization - Material Ingredients	1 / 2
Construction and Demolition Waste Mgmt	1 / 2

Is this **good or bad**?

Does it mean our building is **“healthy”**?

What about the products that weren't on the **calculator**?



Green Bodger

# Bespoke Enhanced Tracking...

Spec #	Keynote	Spec Name	Product Type	VOC Emissions Testing Compliant	VOC Content Compliant	Composite Wood Formaldehyde Emissions	Ingredient Transparency: 100 ppm	Ingredient Transparency: 1,000 ppm	Red List Free	Red List Compliant	Industry-Wide EPD	Product-Specific EPD	DFF Compliant, Disclosed	FSC Wood	Biobased	Reused or Salvaged	Manufacturer Take Back Program
030143	0301P	Repair of Gypsum Concrete Plank Deck	Precast, lightweight nailable deck planks				o	o	o	o	o	o	o				
030143		Repair of Gypsum Concrete Plank Deck	Gypsum Concrete Patching compound				o	o	o	o	o	o	o				
033500	0335C1	Concrete Finishing	Diamond Polishing Concrete Floors		X		X		o	o			o				
033500		Concrete Finishing	Diamond Polishing Concrete Floors: Accessories	X	X		X		X				o				
041000	0410M	Stone Restoration and Cleaning	Parge Coat				o	o	o	o	o	o	o				
041000	0410S1	Stone Restoration and Cleaning	Replacement Sandstone to match existing							o	o	o	o				
041000	0410S2	Stone Restoration and Cleaning	Replacement Limestone to match existing				X		X		o	o	o				
041000		Stone Restoration and Cleaning	Stone Repair Mortar				o	o	o	o	o	o	o				
041000		Stone Restoration and Cleaning	Stone Repair Mortar				o	o	o	o	o	o	o				
044200	0442A	Stone Assemblies: Anchors	Adjustable Masonry Veneer Anchors				X		o	o	o	o	o				
044200	0442A1	Stone Assemblies: Anchors	Seismic Veneer Buck Anchor				X		o	o	o	o	o				
044200	0442D	Stone Assemblies	Drainage Fabric/ Board				o	o	o	o		X	o				
044200	0442DM	Stone Assemblies	High-Temperature Membrane Underlayment				o	o	o	o	o	o	o				
054000	0540C	Cold-Formed Metal Framing	CFMF C Studs	X				X	o	o		X	o				
054000	0540Z	Cold-Formed Metal Framing	Resilient Channel Furring	X			X			X		X	o				

# Bespoke Enhanced Tracking...

Spec Section	Manufacturer	Material ID	Product Name	MRc4: Documentation Type	Chemicals of Concern: Category	Chemicals of Concern: Red List Free?	Chemicals of Concern: Ingredient Info Available?	Chemicals of Concern: Ingredient Document Type	Chemicals of Concern: Compliant?
Added to Div 01 spec	ARCHITECTURAL MATERIALS								
	FINISHES								
095113	Armstrong	ACT	Calla	Declare Label	Ceiling	Yes	Yes		Yes
095113	Armstrong	ACT	Lyra PB Direct Apply	Declare Label	Ceiling	No	Yes		Substituted
095113	Armstrong	ACT	Calla Healthzone	Declare Label	Ceiling	Yes	Yes	HPD	Yes
095113	Armstrong	ACT	Clean Room VL		Ceiling	No	Yes	SDS	Yes
095113	Armstrong	ACT Grid	Suprafine	Declare Label	Ceiling	Yes	Yes		Yes
096813	Shaw Contract	CPT	Knotted Tile	Declare Label	Flooring	No	Yes	HPD	Yes
096813	Interface	CPT	Darning	Cradle to Cradle Certified	Flooring	No	Yes	HPD	Yes
096813	Milliken	CPT	Heavy Meta; Alloy	Declare Label	Flooring	Yes	Yes		Yes
093000	Mosa Tile	CTB	Global Collection	Declare Label	Flooring	Yes	Yes		Yes
096623	Terrazzo & Marble	TER	Epoxy Resin Terrazzo Floor	Declare Label	Flooring	Yes	Yes		Yes
097200	Forbo	CWC	Bulletin Board	HPD	Wall	No	Yes	HPD	Yes
097200	Filzfelt	FELT	Felt Wall Covering	Declare Label	Wall	Yes	Yes		Yes
097200	Carnegie Fabric	FWC	Xorel Tangle	Declare Label	Wall	Yes	Yes		Yes
096500	Flexco	RB	Color: Bonsai 509	HPD	Wall	No	Yes	HPD	Yes
097713	Carnegie	AST-11	Xorel, Galway	HPD	Ceiling/Wall	Yes	Yes	HPD	Yes
092900	CertainTeed	GYP BD-2 (opt1)	M2Tech Type X Gypsum Board	HPD	Ceiling/Wall	No	Yes	HPD	Yes
092900	G-P Gypsum	GYP BD-2 (opt2)	ToughRock Mold-Guard Fireguard X	HPD	Ceiling/Wall	No	Yes	HPD	Yes
092900	National Gypsum	GYP BD-2 (opt3)	Gold Bond Brand XP Fire-Shield Gypsum Board	HPD	Ceiling/Wall	No	Yes	HPD	Yes
092900	USG	GYP BD-2 (opt4)	SHEETROCK Brand Mold Tough Firecode Gypsum Panel	HPD	Ceiling/Wall	No	Yes	HPD	Yes
092900	CertainTeed	GYP BD-16 (opt1)	1/4 inch Flex Gypsum Board	HPD	Ceiling/Wall	No	Yes	HPD	Yes
092900	Georgia-Pacific	GYP BD-16 (opt2)	ToughRock Flexroc Gypsum Board		Ceiling/Wall	No	Yes	SDS	Substituted
092900	National Gypsum	GYP BD-16 (opt3)	Gold Bond Brand High Flex Gypsum Board		Ceiling/Wall	No	Yes	SDS	Yes
092900	USG	GYP BD-16 (opt4)	SHEETROCK Brand 1/4 inch Flexible Gypsum Panels		Ceiling/Wall	No	Yes	SDS	Yes
092900	National Gypsum	GYP BD-38 (opt2)			Ceiling/Wall	No	Yes	HPD	Yes
092900	USG	GYP BD-38 (opt3)	Gold Bond Brand Hi-Abuse XP Gypsum Board	HPD		No	Yes	HPD	Yes
092900	USG	GYP BD-38 (opt3)	SHEETROCK Brand Mold Tough Abuse-Resistant Firecode X Panels	HPD		No	Yes	HPD	Yes
092900	USG	GYP BD-21	Mold Tough Gypsum Liner Panels	HPD	Ceiling/Wall	No	Yes	HPD	Yes
092900	National Gypsum	GYP BD-23 (opt2)	PermaBasa Cement Board	HPD	Ceiling/Wall	No	Yes	HPD	Substituted
092900	USG	GYP BD-23 (opt3)	DUROCK Cement Board	HPD	Ceiling/Wall	No	Yes	HPD	Yes
092900	CertainTeed	GYP BD-25 (opt1)	GlasRoc Diamondback Tile Backer Type X Board	HPD	Ceiling/Wall	No	Yes	HPD	Yes
092900	National Gypsum	GYP BD-25 (opt3)	eXP Tile Backer Fire-Shield Type X	HPD	Ceiling/Wall	No	Yes	HPD	Yes
092900	USG	GYP BD-25 (opt4)	Durock Glass-Mat Tile Backerboard Type X		Ceiling/Wall	No	Yes	SDS	Yes

# Bespoke Enhanced Tracking...

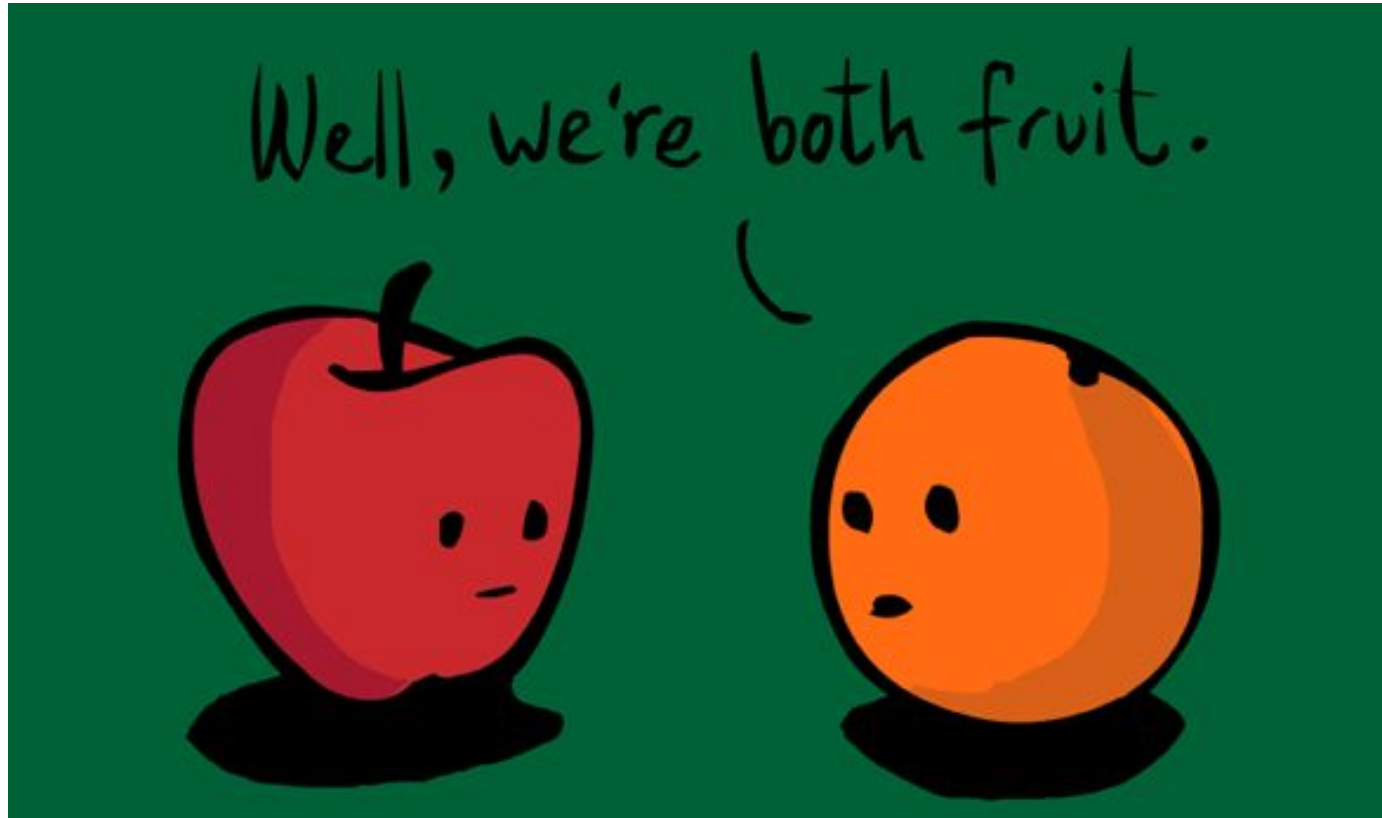

# Moving to an Aligned Framework



**Human  
Health**



**Climate  
Health**



**Ecosystem  
Health**



**Social Health  
& Equity**



**Circular  
Economy**

# Standardizing Auditing & Tracking

## Common Materials Framework

### HUMAN HEALTH

Transparency	78	52	
Red List Free	26	104	
VOC Emissions	70	30	N/A
VOC Content	20	5	N/A

### CLIMATE HEALTH

EPDs	32	98
------	----	----

### ECOSYSTEM HEALTH

FSC Wood	10	5	N/A
----------	----	---	-----

### SOCIAL HEALTH + EQUITY

JUST, B-Corp	5	125
--------------	---	-----

### CIRCULAR ECONOMY

Take-Back Program	5	125
-------------------	---	-----

## Focus on Human Health

SUBSTANCES

- Red List Free
- Well Disclosed
- Limited Disclosure
- Undisclosed

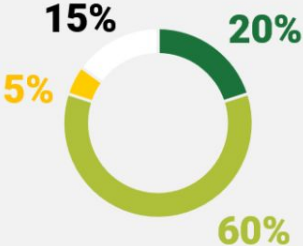

## Focus on Embodied Carbon



OF PRODUCTS WITH A CLF BENCHMARK

**HAVE EPDS**

# Percent of Products with $\geq 1$ CMF Attribute

(Products in AIA MP Categories)

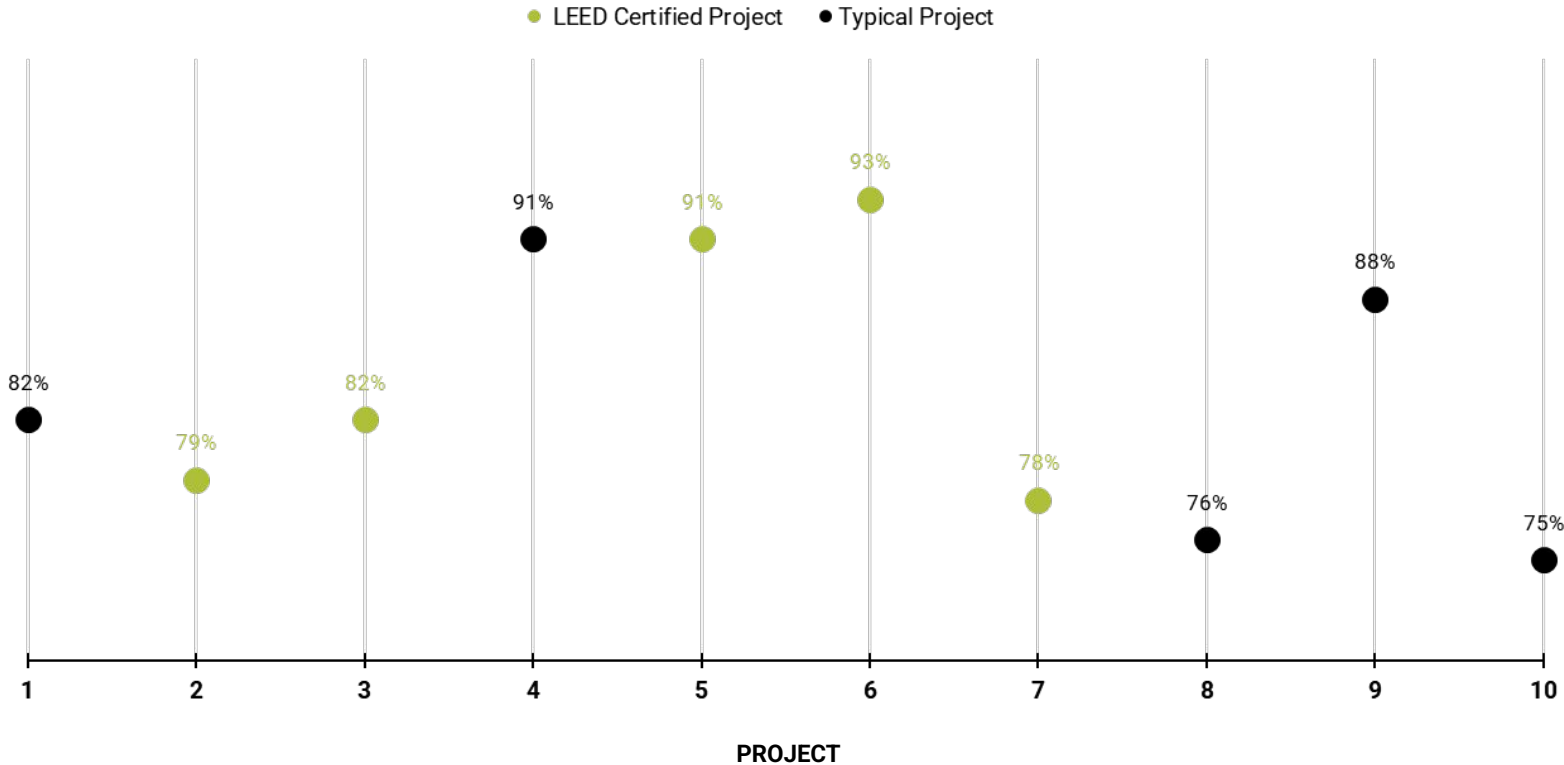

# Percent of Products with $\geq 1$ CMF Attribute (Products in AIA MP Categories)

- LEED Certified Project
- Non LEED Project
- Total AIA Product Count
- Count with  $\geq 1$  CMF Attribute

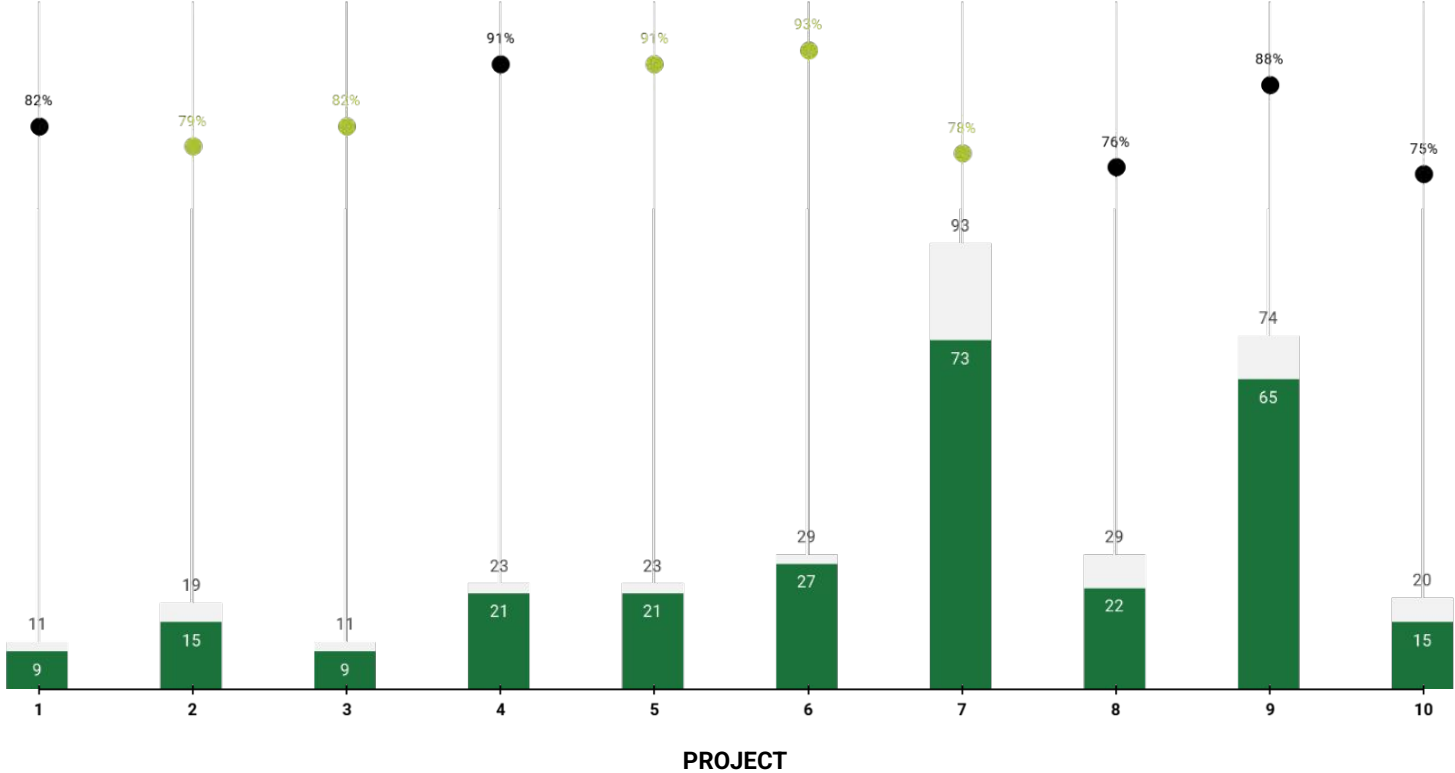

# LEED V5 & CMF as Armature

**Table: 1. Product Documentation Scores in LEED v5**

Eligible Product Documentation	Criteria Areas					LEED Multi-Attribute Score (max = 5)
	Human Health	Climate Health	Ecosystem Health	Social Health & Equity	Circular Economy	
Biobased Content, Non-Wood (½ x verified biobased content %)	-	-	-	-	%	up to 1
BIFMA LEVEL (2019): achievement of 7.5.1.1 or 7.5.2.2	1	*	-	-	%	1+
BIFMA LEVEL (2024) Tier 1 or Tier 2	-	*	-	-	%	up to 2
BIFMA LEVEL (2024) Tier 3	1	*	-	1	%	2+
BIFMA LEVEL (2024) Tier 4	2	*	1	1	1	5
Cradle to Cradle: Bronze (Version 3.1)	1	-	-	-	%	1+
Cradle to Cradle: Bronze (Version 4.0/4.1)	1	-	-	1	%	2+
Cradle to Cradle: Silver (Version 3.1)	2	-	-	1	%	3+
Cradle to Cradle: Silver (Version 4.0/4.1)	2	1	1	1	1	5
Cradle to Cradle: Gold (Version 3.1)	3	1	1	1	1	5
Cradle to Cradle: Gold (Version 4.0/4.1)	3	2	1	2	2	5
Cradle to Cradle: Platinum (Version 3.1)	3	2	2	2	2	5
Cradle to Cradle: Platinum (Version 4.0/4.1)	3	3	2	3	3	5
Cradle to Cradle: Certified Circularity, Bronze (v4.1)	1	-	-	-	%	1+
Cradle to Cradle: Certified Circularity, Silver (v4.1)	1	-	-	-	1	2
Cradle to Cradle: Certified Circularity, Gold (v4.1)	1	-	-	-	2	3

Individual Product Results						
Human Health	Climate Health	Ecosystem Health	Social Health and Equity	Circular Economy	Multi-Attribute Score (Max 5)	BPSP Adjusted Value
2	1	1	1	1.00	5.00	390
2	1	0	0	0.00	3.00	2694
0	1	0	0	0.00	1.00	7989
0	1	0	0	0.00	1.00	786
0	3	2	0	0.00	5.00	280
2	1	0	1	0.00	4.00	1816



# Moving to an Aligned Framework

1. **New Standard (Spring 2026):** All interior products for projects with sufficient scope to be documented using **LEED V5 Building Products Calculator**, included in BOD submission.

*Required to be documented: Paints & Coatings, Flooring, Ceilings, Walls, Wood. Encouraged: Adhesives & Sealants, Insulation, Furniture, Composite Wood, Plumbing Fixtures.*

2. **Aspirational Goal: For major projects,** all specified high-touch materials (flooring, walls, furniture, paints) shall achieve LEED V5 score of 2 or higher for Human Health.
3. What other **stretch goals** are realistic for Yale to integrate?

# LEED V5 Multi-Attribute Optimization Points

## Project 6 - Lapham Field House Renovation

■ Level 1 ■ Level 2

Product Level Count

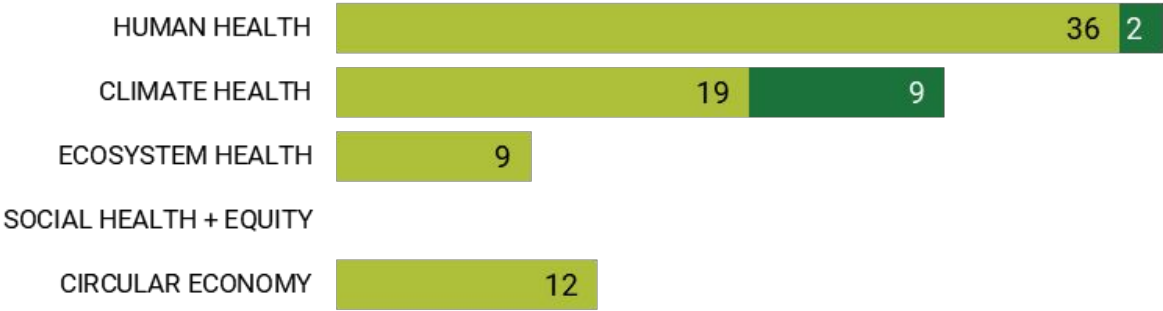

# Take Advantage of Emerging Databases



Yale

LEED V5

Raw Data

Aggregation Database

Portfolio Report

# Architect's Perspective



# Material Selection

Codes

Aesthetics

Performance

Social health & Equity



Climate Health



Human Health Hazards



Cost

Circular Economy



Ecosystem Health





# Human Health | Where To Start

## Request transparency

- Health Product Declarations (HPD)
- Declare Label
- Living Product Challenge (LPC)
- Cradle to Cradle (C2C)
- BIFMA LEVEL
- OEKO-TEX

## Eliminate “red list” chemicals

- ILFI Red List
- Green Science Policy Institute’s Six Classes
- Cradle to Cradle Banned List of Chemicals

## Integrate VOC limits & emissions test thresholds

**Armstrong Commercial Ceilings Ultima**  
by Armstrong World Industries

CLASSIFICATION: 095100

PRODUCT DESCRIPTION: A smooth visual ceiling with Total Acoustics™ performance - sound absorption and blocking needed for today's flexible spaces; durable finish - Washable, Impact-resistant, Scratch-resistant, Soil-resistant.

**Health Product Declaration v2.1**

created via: HPDC Online Builder

**Section 1: Summary**
Basic Method / Product Threshold

**CONTENT INVENTORY**

Inventory Reporting Format:	Threshold level:	Residuals/Impurities:	Are All Substances Above the Threshold Indicated:
<input type="checkbox"/> Nested Materials Method	<input type="checkbox"/> 100 ppm	<input checked="" type="checkbox"/> Considered	<input type="checkbox"/> Characterized
<input checked="" type="checkbox"/> Basic Method	<input checked="" type="checkbox"/> 1,000 ppm	<input type="checkbox"/> Partially Considered	<input type="checkbox"/> Percent Weight and Rate Provided? <input type="checkbox"/> Yes <input type="checkbox"/> No
<b>Threshold Disclosed Per</b>	<input type="checkbox"/> Per OSHA SDS	<input type="checkbox"/> Not Considered	<input type="checkbox"/> Screened
<input type="checkbox"/> Material	<input type="checkbox"/> Per OSHA MSDS	<input type="checkbox"/> Experimental provided for Residuals/Impurities?	<input type="checkbox"/> Using Priority Hazard Lists with Results Disclosed? <input type="checkbox"/> Yes <input type="checkbox"/> No
<input checked="" type="checkbox"/> Product	<input type="checkbox"/> Other	<input type="checkbox"/> Yes <input type="checkbox"/> No	<input type="checkbox"/> Identified Name and Identifier Provided? <input type="checkbox"/> Yes <input type="checkbox"/> No

**CONTENT IN DESCENDING ORDER OF QUANTITY**

Summary of product contents and results from screening individual chemical substances against HPD Priority Hazard Lists and the GreenScreen for Safer Chemicals®. The HPD does not assess whether using or handling this product will expose individuals to its chemical substances or any health risk. Refer to Section 2 for further details.

**MATERIAL | SUBSTANCE | RESIDUAL OR IMPURITY | HAZARD TYPE**

ULTIMA CEILING PANELS | MINERAL WOOL (BIOSOLUBLE, WITH ALKALINE OXIDE AND ALKALI EARTH OXIDE CONTENT GREATER THAN 18 % BY WEIGHT) | **RE-1** | CAN FIBERGLASS, BIOSOLUBLE AND/OR WITH ALKALINE OXIDE AND ALKALI EARTH OXIDE CONTENT <18 % BY WEIGHT | **RE-1** | CELLULOSE PULP | **RE-1** | STARCH | **RE-1** | HYDROXYETHYL CELLULOSE | **RE-1** | END LIMESTONE, CALCIUM CARBONATE | **RE-1** | CALCIUM CARBONATE | **RE-1** | DOLOMITE | **RE-1** | STARCH | **RE-1** | KAOLIN CLAY | **RE-1** | CAN DOLOMITE | **RE-1** | POLYVINYL ALCOHOL | **RE-1** | MELANINE D-YANTRATE | **RE-1** | ETHYLENE COPOLYMER | **RE-1** | UNDISCLOSED | **RE-1** | RES FATTY ACIDS, C16-22 AND C18 UNSATD. (FATTY ACIDS, C16-22 AND C18 UNSATD) | **RE-1** | TITANIUM DIOXIDE | **RE-1** | CAN | END POLYVINYL ACETATE (PVA) | **RE-1** | QUARTZ | **RE-1** | CAN STARCH, PHOSPHATE | **RE-1** | SILICA, AMORPHOUS | **RE-1** | CAN ALUMINA TRIHYDRATE | **RE-1** | RES |

**VOLATILE ORGANIC COMPOUND (VOC) CONTENT**

VOC Content data is not applicable for this product category.

**CERTIFICATIONS AND COMPLIANCE** See Section 3 for additional listings

VOC emissions: Clear Chem - Berkeley Analytical - Third Party compliant with CONDEX-B-604 Method v1.1 (2016). VOC Certificate of Compliance for Ultima LCA: Environmental Product Declaration

Other: International Living Future Institute - Ultima AirGuard Declare Label

**CONSISTENCY WITH OTHER PROGRAMS**

Pre-checked for LEED v4 Material Ingredients, Option 1

Third Party Verified?	PREPARED: Self-Prepared	SCREENING DATE: 2017-08-28
<input type="checkbox"/> Yes	VERIFIER: VERIFICATION #:	PUBLISHED DATE: 2017-08-29
<input checked="" type="checkbox"/> No		EXPIRY DATE: 2020-08-28

# Payette Material Policy

## A Targeted Approach

**NO:**

HIGHLY FLUORINATED CHEMICALS



FLAME RETARDANTS



ANTIMICROBIALS



VINYL



Human  
Health



Social  
Health  
&  
Equity

# Product Selector Cards



Human Health



Social Health & Equity

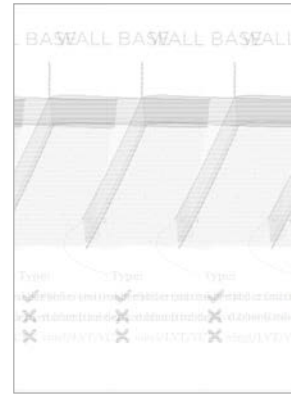
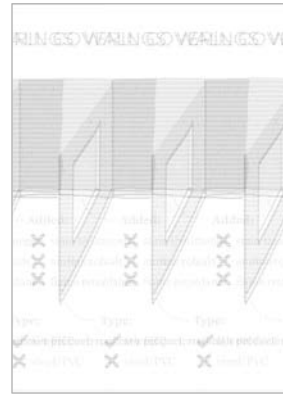
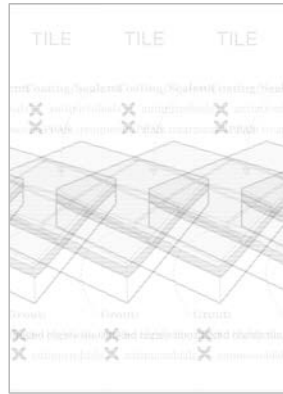
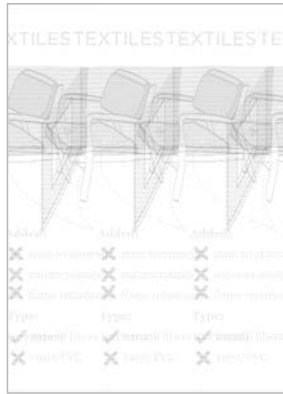
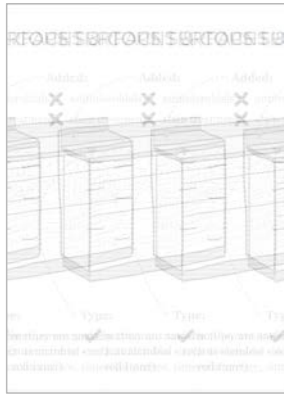
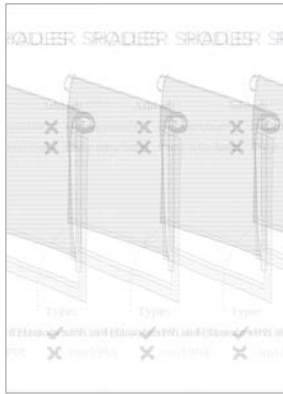
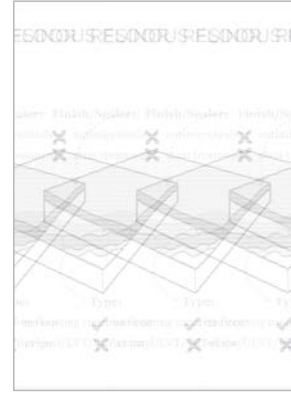
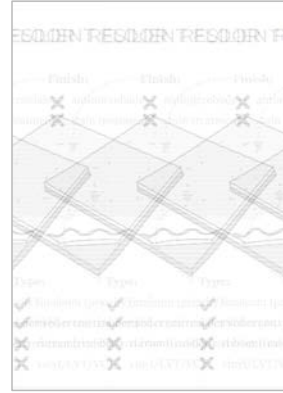
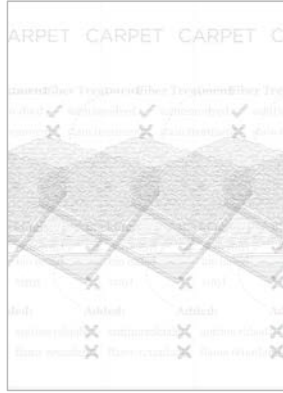
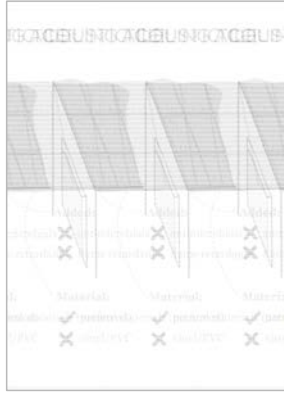

# Social Health & Equity | Where to Start

## Ask manufacturers for supplier codes of conduct

- Require their supply chain sources to comply with human rights guidelines

## Social hotspots / human rights labor risk for commonly specified products

- Design for Freedom report
- Social Hotspots Database

## Select products that meet requirements of abolition of forced labor, elimination of child labor, freedom of association, and equality

- International Labour Organization (ILO) Core Conventions
- LEED pilot credit “Social Equity within the Supply Chain”



International  
Labour  
Organization



Social  
Health  
&  
Equity

The image shows a screenshot of a 'design for FREEDOM supplier questionnaire' form. The form is titled 'design for FREEDOM supplier questionnaire' and includes a hummingbird logo. It contains several sections: a header, a disclaimer, a company information section, a high-risk materials section, organizational questions, and risk assessment questions. The form is partially filled out with handwritten text.

design for FREEDOM  
supplier questionnaire

At a supplier for this project, our team is asking you to complete this questionnaire in order to disclose transparency about your products. Please provide responses to each question below and provide back up or supplemental documentation as necessary.

Company Name: nora systems GmbH  
Date: 01.08.2022  
Product Name: various rubber flooring products  
Product Number: \_\_\_\_\_

Does this product contain any of the following high-risk materials (check all that apply)?  
 Bricks  Copper  Electronics  Glass  Iron  Minerals  Polysilicon  Precursors  
 Rubber  Steel  Stone  Textiles  Timber

Organizational questions (transparency & data collection)

1. Please list the country(ies) in which your organization is headquartered?  
Germany

2. Please list the country(ies) where your organization manufactures this product?  
Germany

3. What kind of operations and manufacturing activities do you conduct in your facilities?  
Entire production process located in Weinheim, Germany

4. How many people does your company employ? Approx. 900

Risk assessment questions

5. Do you employ seasonal, transient, migrant, or low-skilled workers? No

6. Is your lowest paid worker receiving a living wage? Yes

Use these living wage calculators specific to your region:  
U.S. Living Wage | Global Living Wage | U.K. Living Wage

designforfreedom.org

# Just Pick Somewhere to Start!



Highest Risk Materials



- Brick
- Copper
- Glass
- Minerals (Mica, Gypsum, Si)
- Polysilicon (Solar Panels)
- Rubber**
- Steel and Iron
- Stone
- Textiles
- Timber

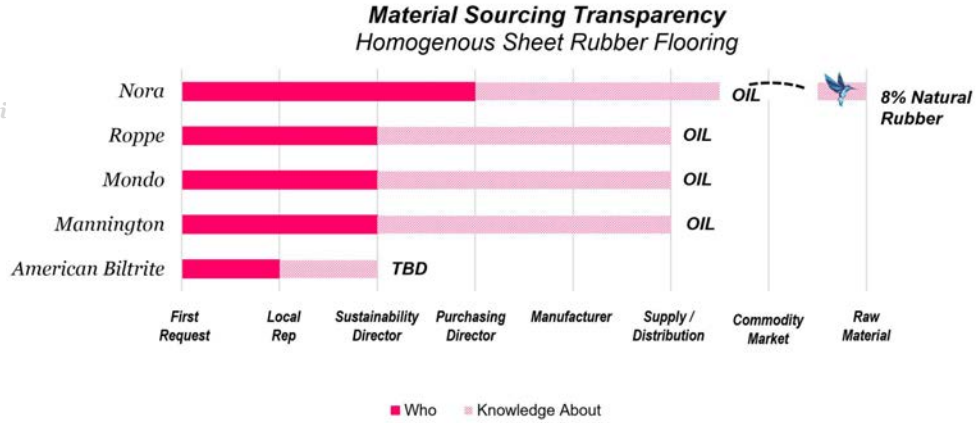

# Ecosystem Health | Where to Start



## Request transparency

- Environmental Product Declarations (EPD)

## Ask about impact to water, air and soil

## Identify high-impact materials

- Petroleum-based plastics and foams
- Metals
- Wood and other structural materials
- Agricultural-based materials

## Specify products with certifications:

- Declare Labels
- Living Product Challenge
- Cradle to Cradle
- FSC
- NSC 337 Stone certification

### EPD Transparency Brief

**Interface**

**COMPANY NAME:** Interface

**PRODUCT TYPE:** CARPET TILE: GLASBAC®, TYPE 6 NYLON

**PRODUCT NAME:** MODULAR CARPET TILE WITH GLASBAC® BACKING & SOLUTION DYED TYPE 6 NYLON

**PRODUCT DESCRIPTION:** Modular carpet with recycled solution dyed Nylon 6 yarn face cloth (yarn weight: 21 oz/lq yd) combined with Glasbac® backing. The products are manufactured by Interface in LaGrange, Georgia USA.

**PRODUCT CATEGORY RULE (PCR):** PCR – Floorcoverings  
Harmonised Rules for Textile, Laminate and Resilient/Floor Coverings

**CERTIFICATION PERIOD:** 9/19/2011-9/19/2016

**DECLARATION NUMBER:** 110919.11CA29311.101.1

**LIFECYCLE IMPACT CATEGORIES**  
The environmental impacts listed below were assessed throughout the product's lifecycle – including raw material extraction, transportation, manufacturing, packaging, use, and disposal at end of life.

ATMOSPHERE	WATER	EARTH
 <b>Global Warming Potential</b> refers to long-term changes in global weather patterns – including temperature and precipitation – that are caused by increased concentrations of greenhouse gases in the atmosphere.	 <b>Acidification Potential</b> is the acidification of the environment's water bodies which leads to the death of plants, animals and other organisms that are sensitive to the acidification caused by human made air pollution.	 <b>Depletion of Abiotic Resources (Fossil Fuels)</b> refers to the reduction of available non-renewable resources, such as metals and glass, that are found in the periodic table of elements, due to human activity.
 <b>Photochemical Smog Creation Potential</b> happens when sunlight reacts with hydrocarbons, nitrogen oxides, and volatile organic compounds to produce a type of air pollution known as smog.	 <b>Eutrophication Potential</b> occurs when excessive nutrients cause increased algal growth in lakes, leading to the underwater proliferation of algae needed to produce oxygen and resulting in the loss of aquatic life.	 <b>Depletion of Abiotic Resources (Soil Health)</b> refers to the decreasing availability of non-renewable carbon-based compounds, such as oil and coal, due to human activity.
<b>GLOBAL WARMING POTENTIAL</b> 10.28 kg CO2-Equiv. 10.57 kg CO2-Equiv.	<b>ACIDIFICATION POTENTIAL</b> 0.006013 kg CFC-11-Equiv. 0.006013 kg R11-Equiv.	<b>DEPLETION OF ABIOIC RESOURCES (FOSSIL FUELS)</b> 0.006018 kg NOx-Equiv. 0.006 kg Ethane-Equiv.
<b>PHOTOCHEMICAL SMOG CREATION POTENTIAL</b> 1.9 mol H <sub>2</sub> -Equiv. 0.046 kg SO2-Equiv.	<b>EUTROPHICATION POTENTIAL</b> 0.003 kg N-Equiv. 0.008 kg Phosphate-Equiv.	<b>DEPLETION OF ABIOIC RESOURCES (SOIL HEALTH)</b> 0.009011 kg So-Equiv.

**FUNCTIONAL UNIT:** One square meter of installed modular carpet for heavy use. The use stage is considered for one year of service life. The reference flow is one square meter of modular carpet.

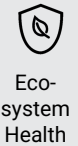

# Learn About Better Alternatives

*Exploration at the scale of A PIECE OF FURNITURE*

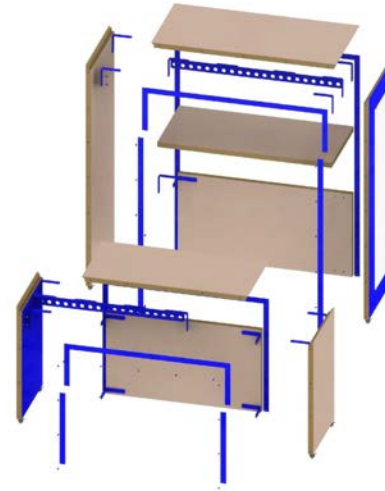

**Exploded Axon**

Community Partner: Breaktime



Eco-  
system  
Health



Climate  
Health

# Climate Health | Where to Start

## Request transparency

- Environmental Product Declarations (EPD)

## Conduct Life Cycle Assessments (LCAs)

## Use low-carbon & carbon sequestering materials

## Evaluate highest-impact areas

- Structure
- Envelope
- Wallboard, Insulation
- Flooring, Ceiling Panels
- MEP

## Advocate for greater transparency & limits of GWP

**CERTIFIED**  
Environmental Product Declaration

**EPD Transparency Brief**

**Interface**  
**CARPET TILE: GLASBAC, TYPE 6 NYLON**  
**MODULAR CARPET TILE WITH GLASBAC BACKING & SOLUTION DYED TYPE 6 NYLON**

**PRODUCT NAME:** Interface  
**PRODUCT TYPE:** CARPET TILE WITH GLASBAC BACKING & SOLUTION DYED TYPE 6 NYLON  
**PRODUCT WEIGHT:** Modular carpet with recycled solution dyed Nylon 6 yarn face cloth (yarn weight: 21 oz/yd) combined with GlasBac backing. The products are manufactured by Interface in California, Georgia, USA.

**PRODUCT CATEGORY:** PCR – Floorcoverings  
**PCR:** Harmonized Rules for Tiles, Laminate and Resilient Floor Coverings

**ISO 14001 CERTIFIED:** 9192011-0132016  
**DECLARATION NUMBER:** 132918-1ICA2011-101-1

**LIFECYCLE IMPACT CATEGORIES**  
 The environmental impacts listed below were assessed throughout the product's lifecycle – including raw material extraction, transportation, manufacturing, and logging, use, and disposal at end of life.

	ATMOSPHERE	WATER	EARTH
	<b>Global Warming Potential (GWP)</b> Global warming potential (GWP) is a metric used to compare the ability of different greenhouse gases to contribute to global warming over a 100-year time horizon. GWP is calculated based on the global warming potential (GWP) of each gas, relative to carbon dioxide (CO2), which is assigned a GWP of 1.0.	<b>Water Depletion Potential (WDP)</b> Water depletion potential (WDP) is a metric used to compare the ability of different materials to contribute to water depletion over a 100-year time horizon. WDP is calculated based on the water depletion potential (WDP) of each material, relative to a reference material, which is assigned a WDP of 1.0.	<b>Acidification Potential (AP)</b> Acidification potential (AP) is a metric used to compare the ability of different materials to contribute to acidification over a 100-year time horizon. AP is calculated based on the acidification potential (AP) of each material, relative to a reference material, which is assigned an AP of 1.0.
<b>100 yr GWP Eq.</b>	4.980023 kg CO2e/kg	0.000019 kg H2O/kg	0.000000 kg SO2e/kg
<b>100 yr GWP Eq.</b>	4.980023 kg CO2e/kg	0.000019 kg H2O/kg	0.000000 kg SO2e/kg

**FUNCTIONAL UNIT:** The square meter of installed modular carpet is used for heavy use. The use stage is considered for one year of service life. The reference flow is a square meter of installed carpet.

Global Warming Potential

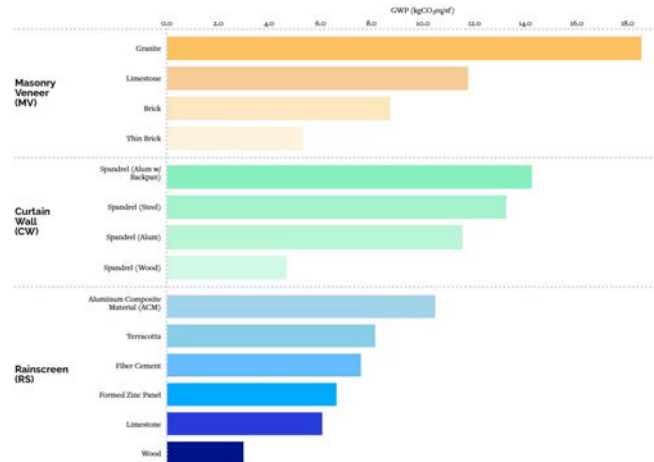

# Learn Successes from Past Projects

GWP/sf per Project

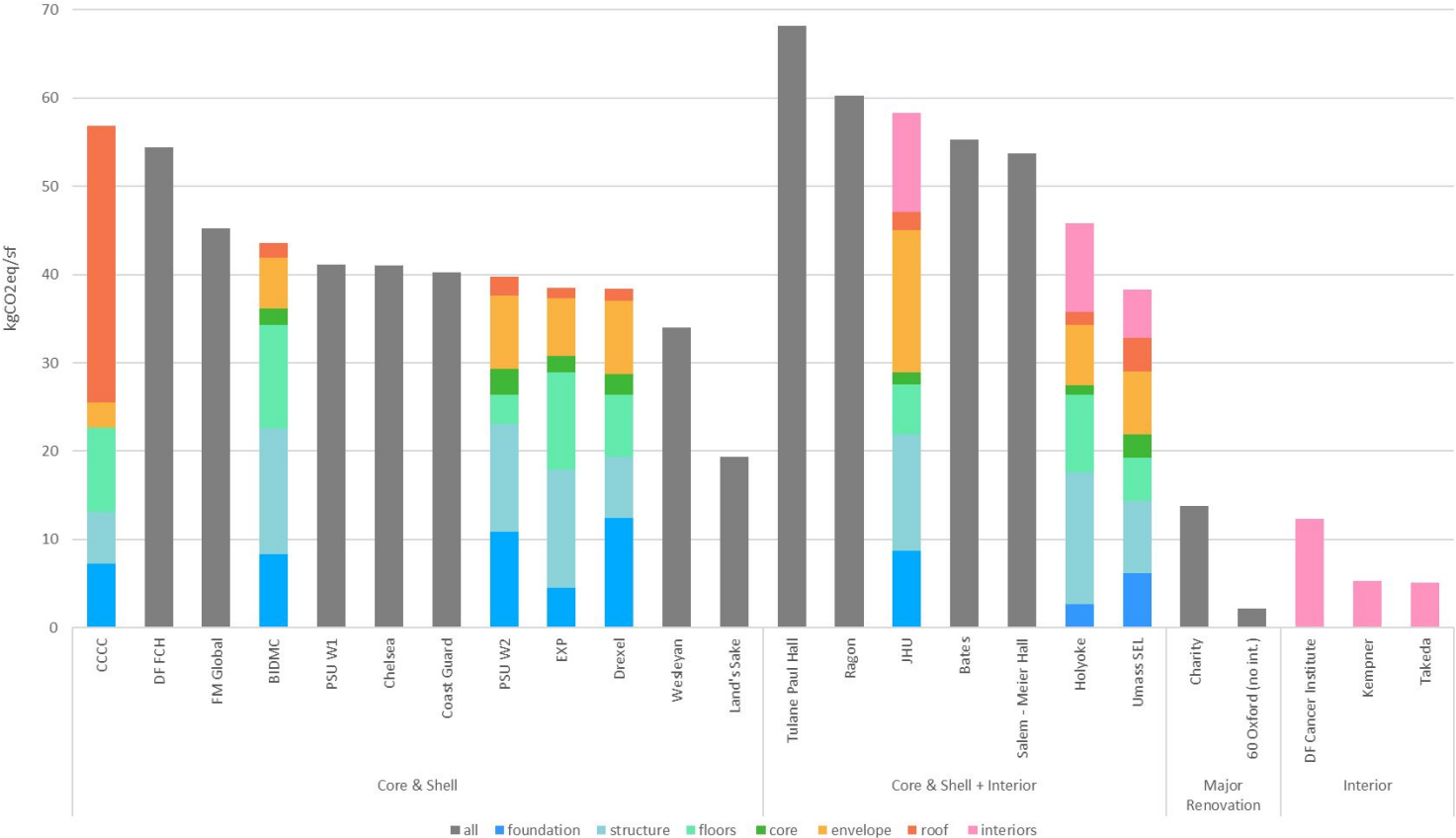

Eco-system Health



Climate Health



Circular Economy

# PAYETTE'S AVERAGE EMBODIED CARBON BREAKDOWN

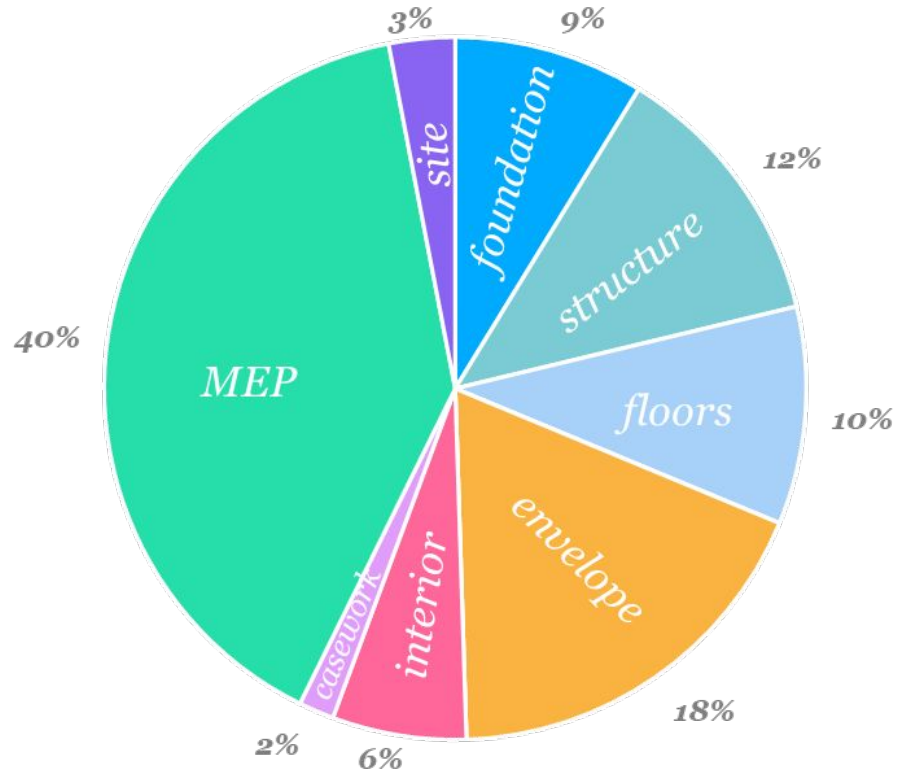

Eco-sys  
tem  
Health



Climate  
Health

# Circular Economy | Where to Start

Renovate, retrofit, and reuse

Design for disassembly or future reuse

Reduce construction waste

- Consider size of typical components

Select materials & furnishings that can be reclaimed

- Or from companies with takeback programs or active product leasing

Require manufacturers to publish end-of-life strategies

## STACKED T-GRID

Suspension Systems

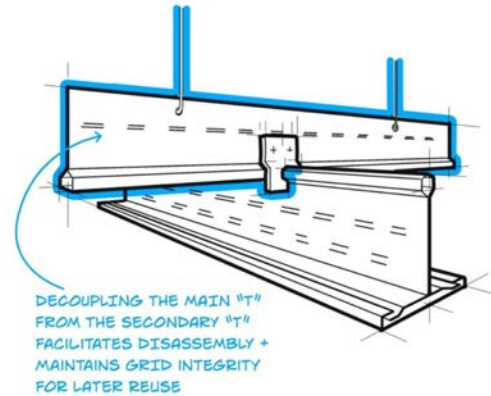

#MetalCeilings #Woodceilings #ACP

### EASE OF DISASSEMBLY



### REUSE POTENTIAL



### EMBODIED CARBON



### DESCRIPTION

Several manufacturers have developed layered suspension systems, most commonly seen with concealed edge metal panel systems. Conceptually, isolating the main tee from the secondary tee by stacking allows for greater flexibility, expedites deconstruction, and could allow for longer life for the upper section. Minimally invasive clips between the grids facilitates deconstruction.

### EXAMPLES

Darako  
SAS ISO  
Armstrong



Circular Economy

# Compile Resources

## Salvaged Materials Resources

### Product Category

Acoustic insulation    Doors    Finish Carpentry    Food Service Equipment    Furniture    Glass

Healthcare equipment    Interior lighting    Lab Equipment    Masonry    Metal    **Millwork**

Miscellaneous    Resource centres    Tiles    Windows

### Product Manufacturers

Deselect all    Almanachard Wood    Deconstruction INC

Elmwood    Etmoore    Jarmakwood

Long leaf lumber    Modern Timber Craft    Pioneer millworks

### Product Description

CSI Number	Product Type
	Reclaimed wood <a href="https://">https://</a>
	Reclaimed Wood floors <a href="https://">https://</a>

### Location

Product Manufacturers ● Almanac... ● Deconstr... ● Elmwood ● Etmoore ● Jarmakw... ● Long leaf L...

Eco-system Health

Climate Health

Circular Economy

# Compile Resources

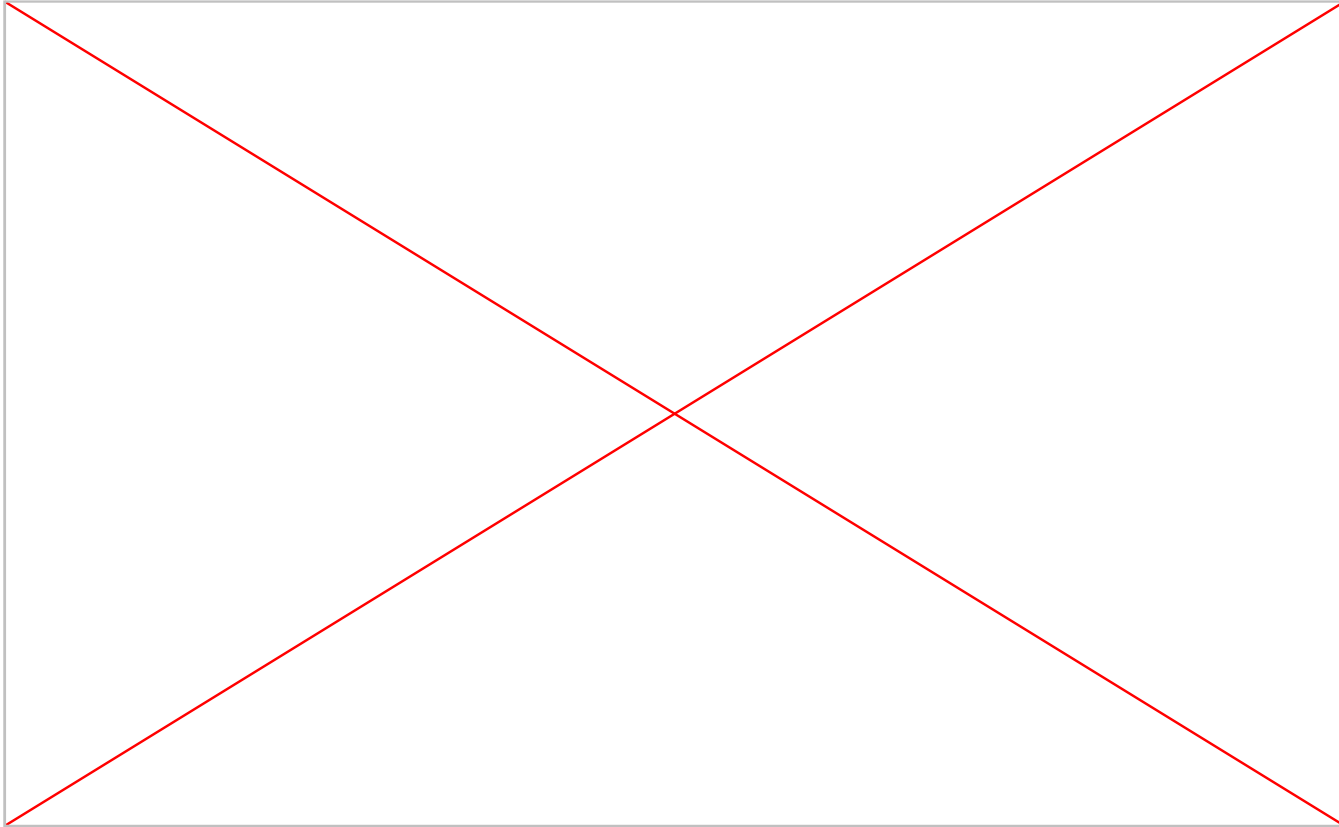

Eco-  
system  
Health



Climate  
Health



Circular  
Economy

# VENDOR COMMUNICATIONS

- Correlate to AIA Materials Pledge!
- Encourage vendors to track down all of the common materials framework
- Encourages dialogue on less frequently discussed topics

## PAYETTE MATERIALS INFORMATION REQUEST FORM

AS SIGNATORIES OF THE AIA MATERIALS PLEDGE, PAYETTE IS DEDICATED TO EVALUATING AND SELECTING MATERIALS FOR THEIR IMPACT ON THE HEALTH AND WELL-BEING OF OUR PEOPLE, OUR COMMUNITIES, OUR ECOSYSTEMS, AND OUR CLIMATE THROUGHOUT THEIR ENTIRE LIFE CYCLE.

Date 2-9-2024

Manufacturer name?	Miliken
Collection name?	All Modular tile on WellBAC Comfort and Comfort Plus
What is the length of your product's warranty?	Lifetime
What is your product's anticipated Life Cycle? (Years)	15
Where is the raw material sourced from? (Country)	US
Where is the manufacturing facility? (Country, State)	Georgia, US
What is the average lead time?	3-4 weeks for DDI and 3-7 weeks for SDN

HUMAN HEALTH	Y/N
Payette Material Policy: Contains Highly Fluorinated Chemicals?	N
Payette Material Policy: Contains Anti-Microbials?	N
Payette Material Policy: Contains Flame Retardants?	N
Payette Material Policy: Contains Polyvinyl Chloride (PVC)?	N
VOC Emissions Certified? (For paints & coatings, adhesives & sealants, flooring, wall panels, ceilings, and insulation, does the product meet CDPH Emissions requirements?)	Y
VOC Content (g/L) Reported?	N
Wood Products are ULEF or NAUF? (CARB compliant)	NA
For furniture - is it compliant with ANSI/BIFMA Standard Method M71-2011 (R2016) and ANSI/BIFMA e3-2014e or e3-2019e Furniture Sustainability Standard?	NA
Fully Declared Health Product Declaration (HPD v2.2 or more recent) to 1000 ppm declaration included?	Y
C2C (version 2.11, 3.0, or more recent version) Certified?	Y
Red List Free?	Y
Contains Formaldehyde?	N
Contains Bisphenols and/or Phthalates?	N
Contains mercury, arsenic, cadmium, or lead?	N

SOCIAL EQUITY & HEALTH	Y/N
Does your company have verified alignment with the ILO Fundamental Conventions?	Y
Does your company have a supplier code of conduct?	Y

ECOSYSTEM & CLIMATE HEALTH	Y/N
Environmental Product Declaration (EPD) - PS: ISO14025/EN15804 or IS: ISO14025/EN15804?	Y
Life Cycle Assessment (LCA) - ISO 14040/14044?	Y

CIRCULARITY	Y/N
100% FSC Certified?	NA
Post-Consumer and/or Pre-Consumer Recycled Content?	Y
For stone, meets ANSI NSC 373 Natural Stone Standard?	NA
Recyclable, or Lease/Take-Back Program for product?	Y
Living Product Challenge?	N

PAYETTE



Human Health



Social Health & Equity



Eco-system Health



Climate Health



Circular Economy



# Construction Manager's Perspective



# Kena David

Director of Sustainability

LEED AP, WELL AP/Faculty, Fitwel Ambassador



# Evolution in LEED

**LEED v1** launched in the 1990's and became the leading green building rating system throughout the world

**LEED v2** came out in 2000 and introduced the multi-tier certification levels. During this version, there was just a LEED AP (no specialty). Many people in the industry took the AP during this phase when it was just one exam

**LEED v3/2009** introduced the online management platform and improved harmonization between rating systems. Most of our subcontractors and clients are STILL used to this version. This was also the version that released the LEED AP Specialties

**LEED v4** (2012, didn't become mandatory until 2016) was a major change in materials with a push for health transparency and embodied carbon

**LEED v5** was announced in beta at the 2023 Greenbuild Conference, marking the most significant update since LEED v2009. The new version focuses on decarbonization, resilience, health, equity, and ecosystem regeneration

# Client Perspective

## Gripes:

- I always got these points on LEED projects, why is this different?
- What is this soft cost for? Documentation control?
- Why can't I get Platinum?

## Result:

- Earlier expectation setting
- Convey the benefits of the changes



# Subcontractor Perspective

## Gripes:

- Recycled content – what is an EPD?
- Embodied Carbon?
- What does HPD stand for?

## Result:

- More training during onboarding & submittals



# Contractor Perspective

## Gripes:

- Submittal timelines extended
- More support from sustainability department
- Database of material documentation?
- Shouldn't a consultant be doing this?

## Result:

- Additional support from Sustainability team
- New services – LCA in house
- Tools like Green Badger

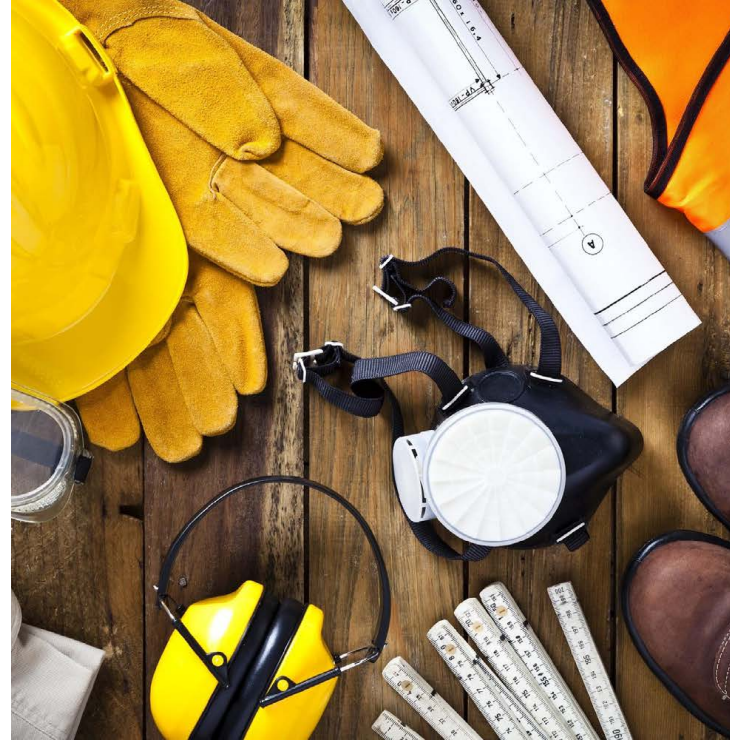

# Focus on Human Health

Reshaping how we look at **Human Health** in LEED

Table: 1. Product Documentation Scores in LEED v5

Eligible Product Documentation	Criteria Areas					LEED Multi-Attribute Score (max = 5)
	Human Health	Climate Health	Ecosystem Health	Social Health & Equity	Circular Economy	
Biobased Content, Non-Wood (½ x verified biobased content %)	-	-	-	-	%	up to 1
BIFMA LEVEL (2024) Tier 1 or Tier 2	-	*	-	-	%	0+
BIFMA LEVEL (2024) Tier 3	1	*	-	1	%	2+
BIFMA LEVEL (2024) Tier 4	2	*	1	1	1	5
Cradle to Cradle: Bronze (Version 3.1)	1	-	-	-	%	1+
Cradle to Cradle: Bronze (Version 4.0/4.1)	1	-	-	1	%	2+
Cradle to Cradle: Silver (Version 3.1)	2	-	-	1	%	3+
Cradle to Cradle: Silver (Version 4.0/4.1)	2	1	1	1	1	5
Cradle to Cradle: Gold (Version 3.1)	3	1	1	1	1	5
Cradle to Cradle: Gold (Version 4.0/4.1)	3	2	1	2	2	5

# Current State of Materials

## Trends in sustainability:

- Embodied Carbon Reduction
- Mass Timber
- LEED
- Living Building Challenge – Red list free
- WELL
- 6 Chemical Classes



# Perception

**Recycled = Old**

**Low toxin = low quality**

**“sustainable” = expensive**

*Gotta have green to be green*



# Path of Least Resistance

**The status quo vs. the easy wins**

*Business as usual with materials is low risk*

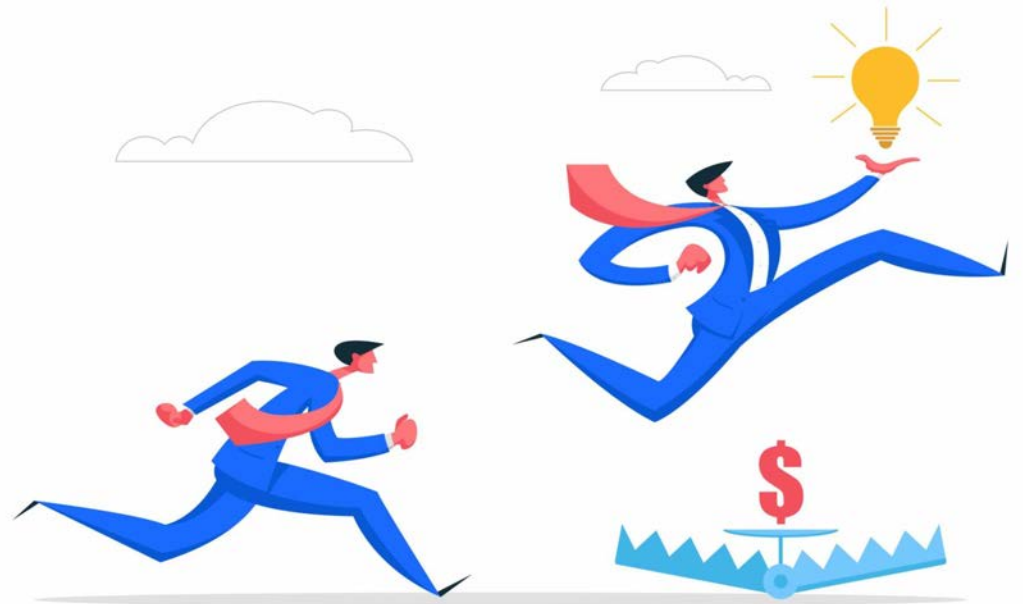

# Low Carbon Concrete

WHO WE

LOW EMBODIED CARBON

MARKET DRIVERS



## ALTERNATIVE MATERIALS



### Ground Glass Pozzolan



# Mass Timber

WHO WE

LOW EMBODIED CARBON

MARKET DRIVERS

## CONSIGLI EXPERIENCE

# 25

## Mass Timber Projects

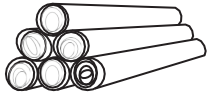

- › In-depth knowledge of Mass Timber construction requirements
- › Pre-construction support to ensure best material & sourcing decisions
- › Extensive pricing & procuring knowledge
- › Hands-on, self-performed installation experience

## PROJECTS IN PROGRESS



UMass CSL



Harvard Garage



Smith College



Harvard Treehouse

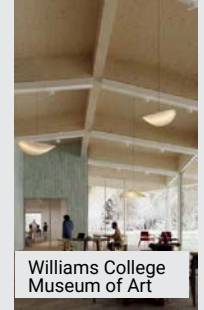

Williams College  
Museum of Art

## COMPLETED PROJECTS



**Bowdoin College**  
Center for Arctic Studies & Barry Mills Hall



**The Cambridge School of Weston**  
Garthwaite Center for Science and Art



**Bates College**  
Boathouse

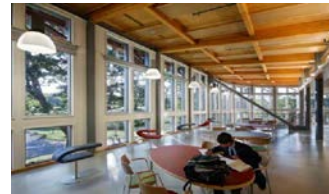

**Brooks School**  
Science Center



**Rockport Music**  
Shalin Liu Performance Center

# Certifications

## Green Building

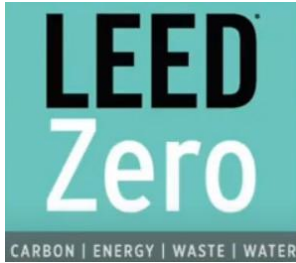

# Legislation

## Municipality Requirements





# Materials Consultant's Perspective

# The Change Curve

✓ Product

Project

Portfolio

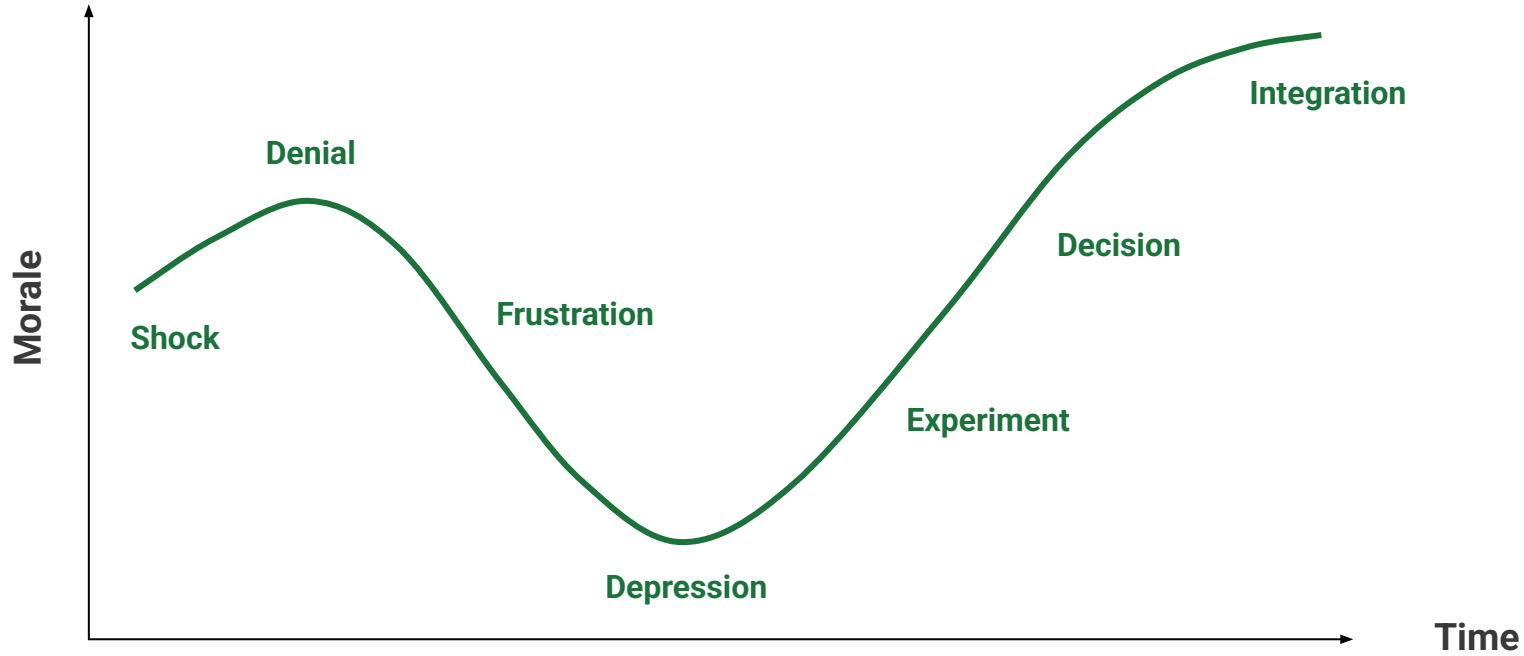

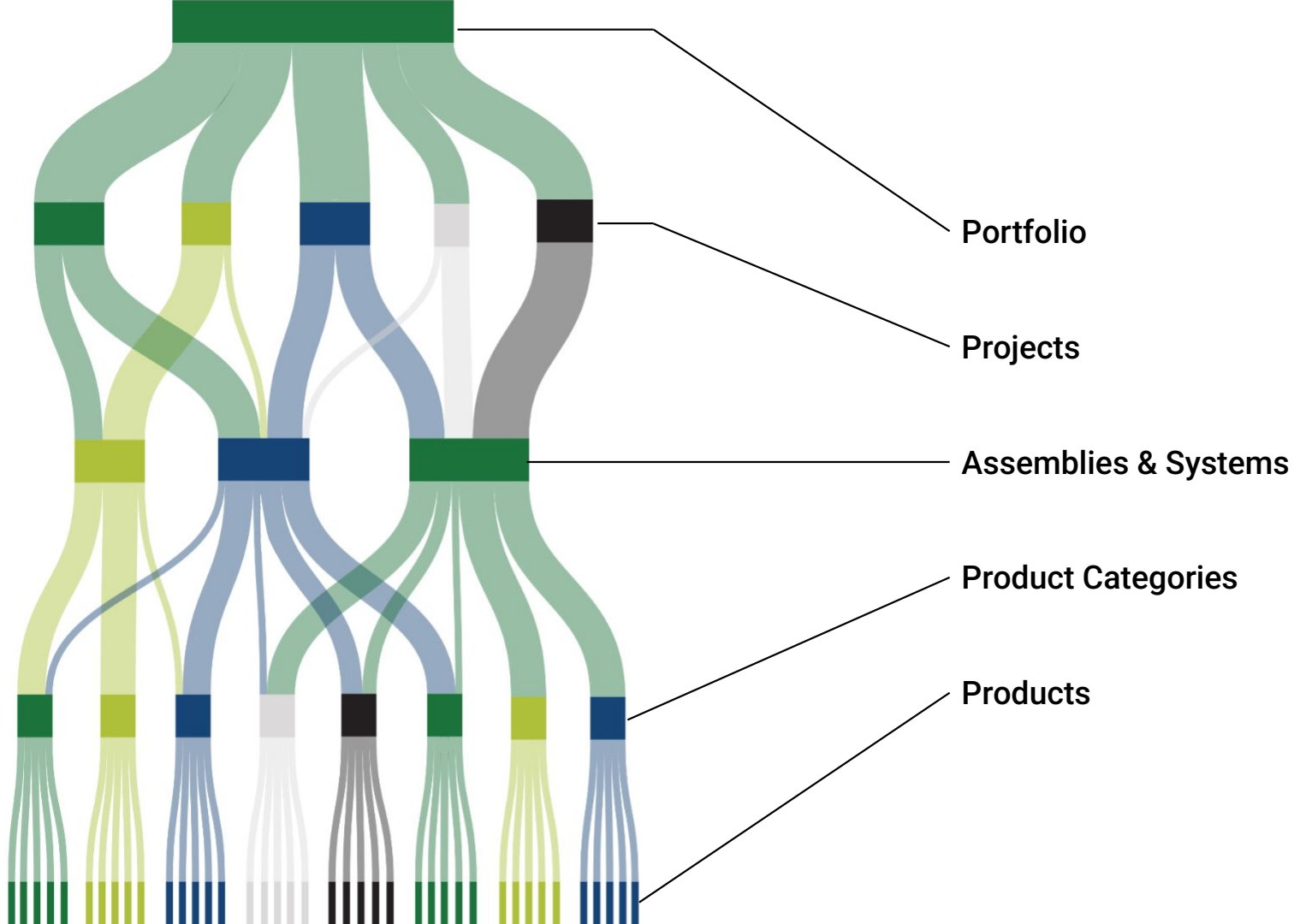

# Product Selection Across Phases

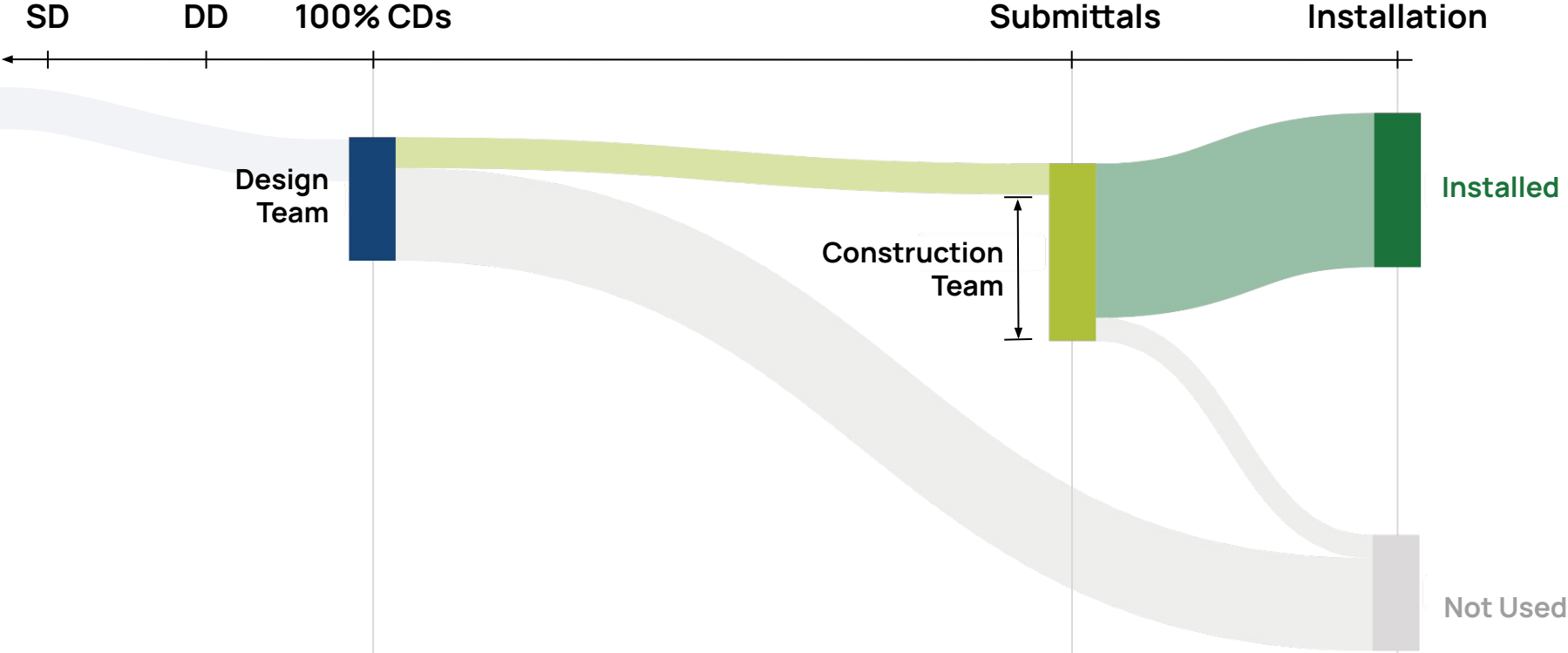

# Yale - Lapham Field House Renovation

**57**  
MANUFACTURERS

**72**  
PRODUCT TYPES

**64**  
PRODUCTS

**52**  
MATCHED PRODUCTS

**93%**  
OF AIA PLEDGE PRODUCTS  
HAVE ≥ 1 CMF ATTRIBUTE

## Common Materials Framework

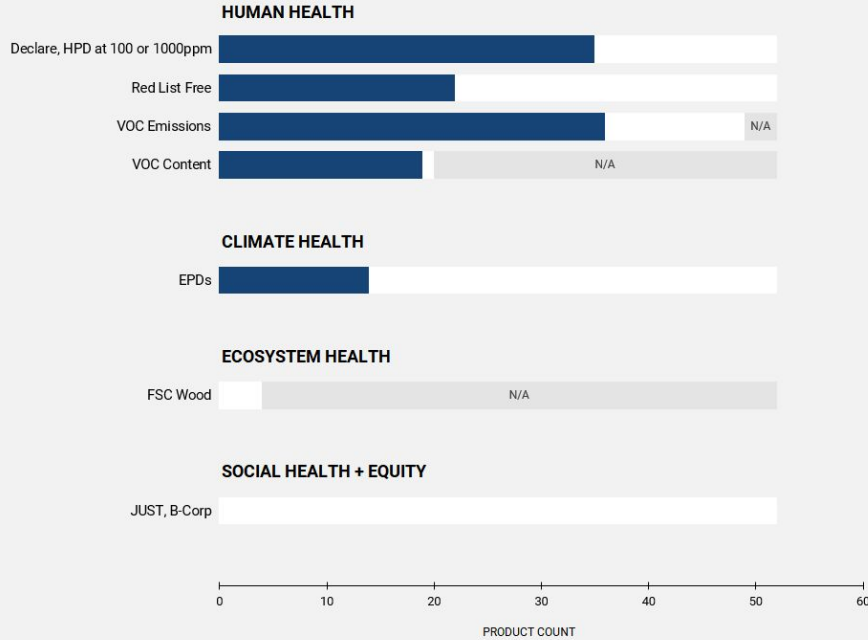

## Focus on Human Health

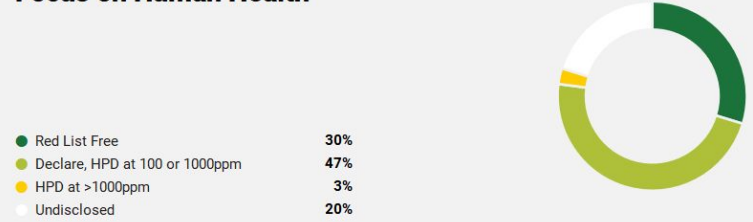

## Focus on Embodied Carbon

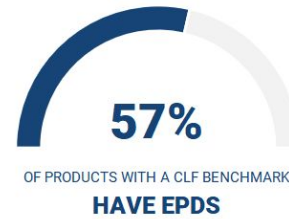

# Project Name

**80**  
MANUFACTURERS

**70**  
PRODUCT TYPES

**130**  
PRODUCTS

**82%**  
OF AIA PLEDGE PRODUCTS  
HAVE ≥ 1 CMF ATTRIBUTE

## Common Materials Framework

### HUMAN HEALTH

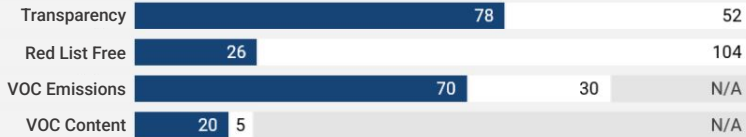

### CLIMATE HEALTH



### ECOSYSTEM HEALTH

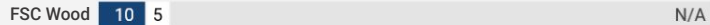

### SOCIAL HEALTH + EQUITY



### CIRCULAR ECONOMY

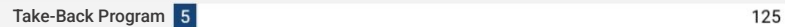

## Focus on Human Health

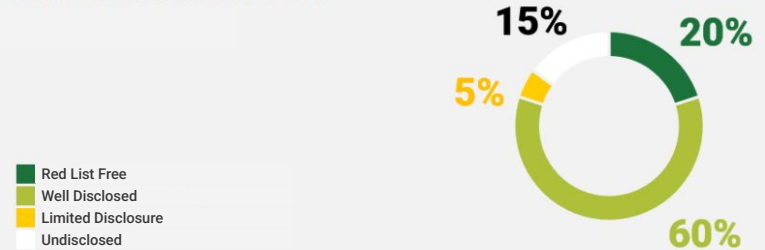

## Focus on Embodied Carbon



OF PRODUCTS WITH A CLF BENCHMARK

**HAVE EPDS**

**GOALS**

*become*

**SPECS**

*become*

**SUBMITTALS**

*become*

**REPORTS**

# BUILDINGENERGY BOSTON

---

Please fill out an evaluation for this session



or: [nesea.org/eval](https://nesea.org/eval)

---

Northeast Sustainable Energy Association (NESEA)

# Contact Us

**Kena David**

[kdavid@consigli.com](mailto:kdavid@consigli.com)

**Andrea Love**

[alove@payette.com](mailto:alove@payette.com)

**Misha SemeLev**

[misha.semelev@yale.edu](mailto:misha.semelev@yale.edu)

**Charley Stevenson**

[charley@materiallybetter.com](mailto:charley@materiallybetter.com)