

March 24, 2026



Lessons from Experience:

Air-to-Water Application & Design for New England & Beyond

SPACEPAK®

Pioneering the AWHP Frontier Since 2011

- “Emerging Market” and “Market Transformation”
- Dedicated since the beginning
- Pioneering the “Emerging Market” and shaping the evolution of AWHP technology and heating electrification in North America
- Thousands of installs and applications
- Leading the industry with over 15 years of experience
- Industry leading warranty



Why SpacePak?



Industry Pioneers

SpacePak is the innovator of small duct high velocity central heating and cooling systems and North American industry leader of air-to-water heat pump technology.



Proven Performance

With thousands of successful installations across the U.S. and Canada, Solstice heat pumps have earned the trust of industry professionals for their unmatched reliability and efficiency.



Unrivaled Warranty

Solstice heat pumps come with an industry-leading 10-year compressor warranty and 5-year parts warranty for SpacePak-certified installers, ensuring long-term peace of mind.



Backed by Mestek

As part of Mestek, a leader in hydronic heating and cooling manufacturing for over 75 years, SpacePak offers unparalleled expertise, training, and support to our partners.



MESTEK, INC.

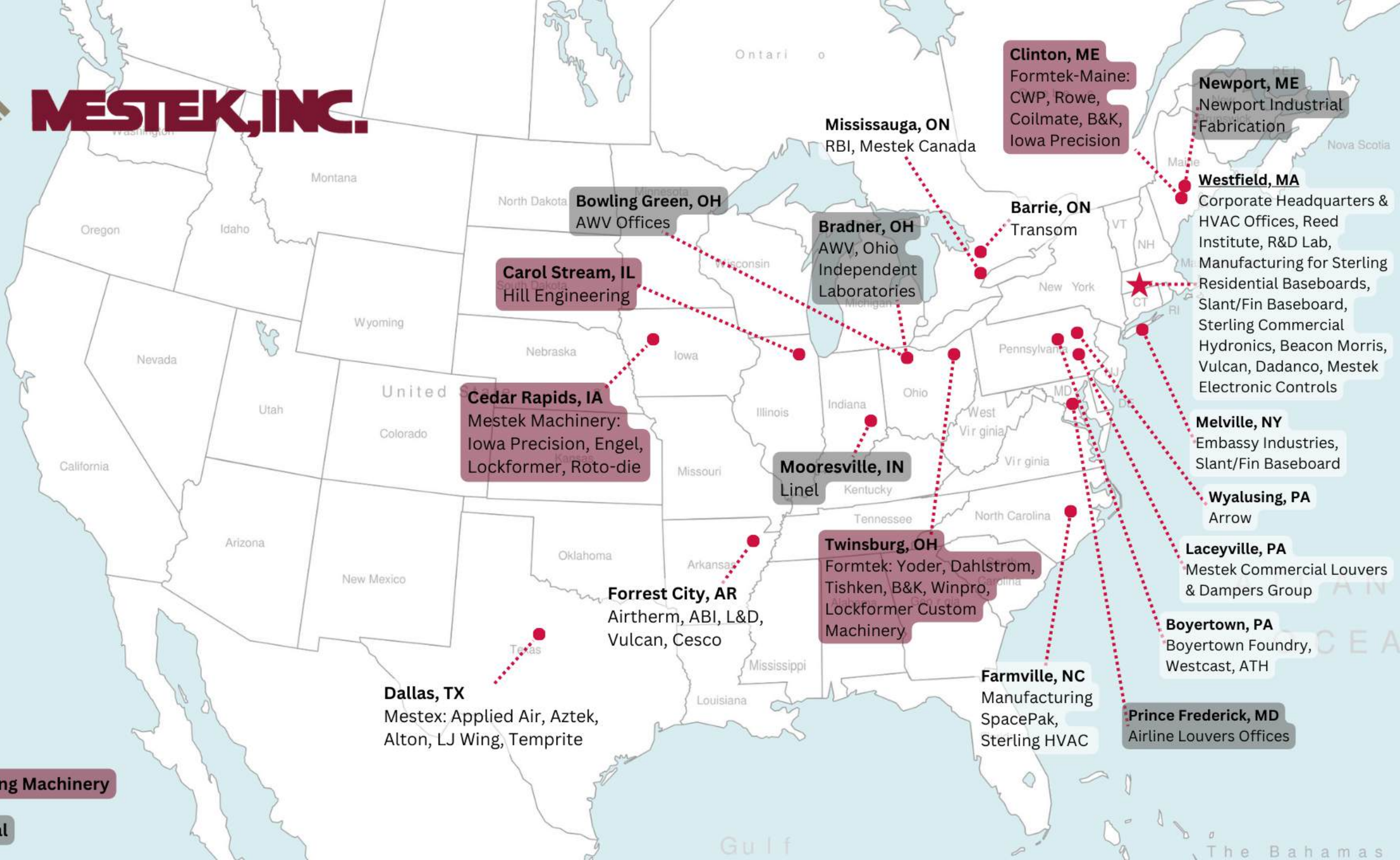

Clinton, ME
Formtek-Maine:
CWP, Rowe,
Coilmate, B&K,
Iowa Precision

Newport, ME
Newport Industrial
Fabrication

Westfield, MA
Corporate Headquarters &
HVAC Offices, Reed
Institute, R&D Lab,
Manufacturing for Sterling
Residential Baseboards,
Slant/Fin Baseboard,
Sterling Commercial
Hydronics, Beacon Morris,
Vulcan, Dadanco, Mestek
Electronic Controls

Barrie, ON
Transom

Mississauga, ON
RBI, Mestek Canada

Bowling Green, OH
AWV Offices

Bradner, OH
AWV, Ohio
Independent
Laboratories

Carol Stream, IL
Hill Engineering

Cedar Rapids, IA
Mestek Machinery:
Iowa Precision, Engel,
Lockformer, Roto-die

Mooreville, IN
Linel

Melville, NY
Embassy Industries,
Slant/Fin Baseboard

Wyalusing, PA
Arrow

Laceyville, PA
Mestek Commercial Louvers
& Dampers Group

Boyertown, PA
Boyertown Foundry,
Westcast, ATH

Prince Frederick, MD
Airline Louvers Offices

Twinsburg, OH
Formtek: Yoder, Dahlstrom,
Tishken, B&K, Winpro,
Lockformer Custom
Machinery

Forrest City, AR
Airtherm, ABI, L&D,
Vulcan, Cesco

Farmville, NC
Manufacturing
SpacePak,
Sterling HVAC

Dallas, TX
Mestex: Applied Air, Aztek,
Alton, LJ Wing, Temprite

HVAC

Metal Forming Machinery

Architectural

Gulf

The Bahamas

SpacePak's AWHP Innovation Leadership Timeline

single speed compressors

first governmental acknowledgement

*variable speed compressors,
higher efficiencies*

2011

2014

2018

2019

2022

2024

SpacePak introduces first Solstice AWHPs, “reverse-cycle chillers”

Launch of first cold climate model, the Solstice Extreme & SSIC integrated control

First State-Level Rebate Program



DOE & EPA recognize Cold Climate AWHPs as Emerging Technology worthy of future Energy Star Program

Launch of next-gen models - Solstice Inverter Series

And 10-year compressor warranty

Launch of next-gen cold climate model, Solstice Inverter Extreme



SE & SCM

LAHP

ENERGY STAR 2019
Emerging Technology Award



SIM & SIS



ILAHP

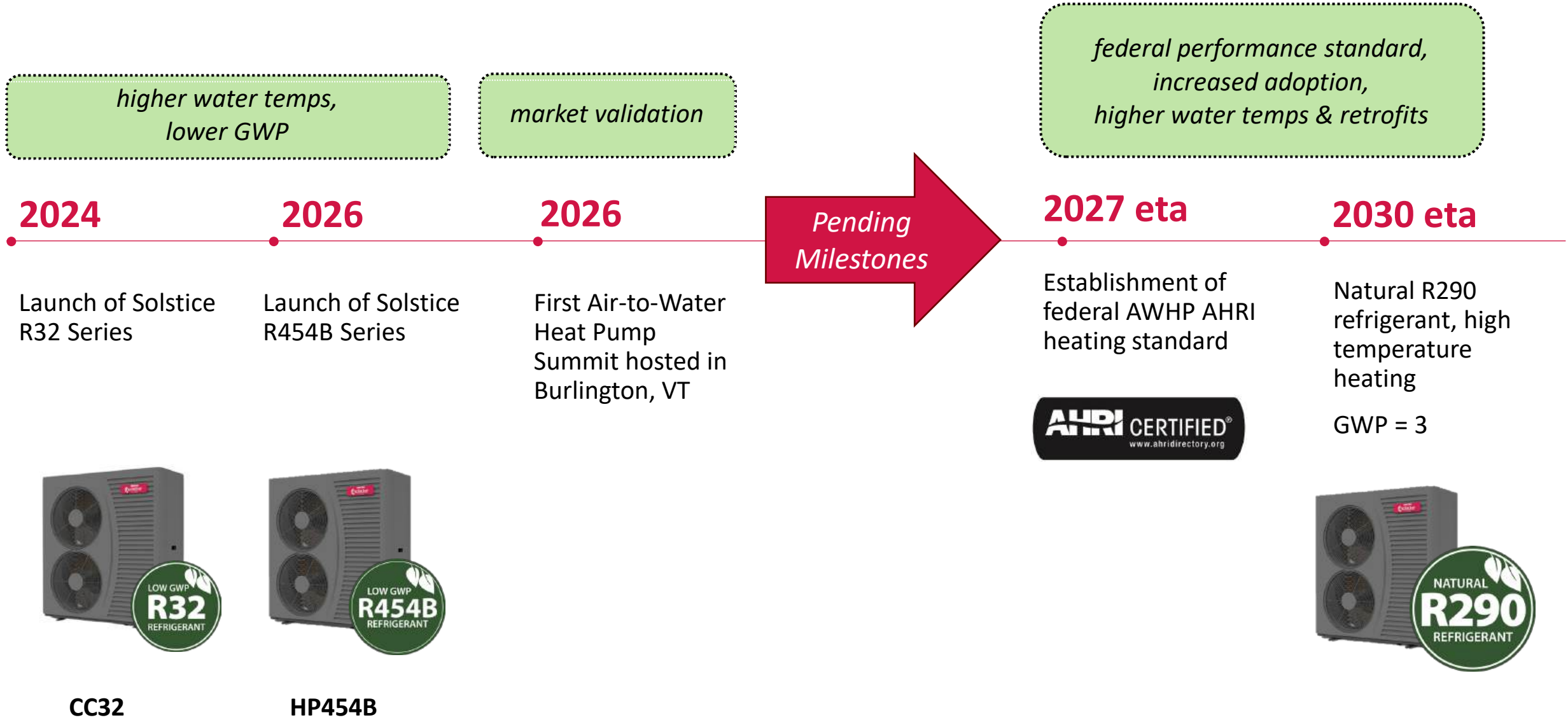

Driving Adoption in an Emerging Market

- The purpose of the EPA's Emerging Technology Award is to accelerate the awareness and adoption of new or under-exposed technologies that have the potential to significantly reduce greenhouse gas emissions
- Emerging Technology = undefined regulatory environment
- Award is a pre-cursor to a future Energy Star program
- Typical air-source HP ratings such as SEER do not apply to AWHP
- Europe and Asia have AWHP performance standards, while the USA & Canada do not **yet**
- Pending AHRI heating standard expected to legitimize and **bridge a huge education gap**
- Currently unfair treatment compared to typical ASHP programs and HERS Ratings
- Recent influx of players into the market helps matu



Early Adopters of Residential AWHP Rebate Programs

Efficiency
Vermont

\$1,000 / ton

mass save[®]

\$1,250 / ton

clean BC
BETTER HOMES

Up to \$3,000

Sonoma
Clean
Power

Up to \$3,000

New York Clean Heat Program

- ✓ Now eligible for Air-to-Water Heat Pumps
- ✓ NYSERDA rebates available
- ✓ Low-interest financing programs available

*Prior to 2024 this program primarily applied to geothermal and air-to-air heat pumps.

“The time for AWHPs is arriving in a powerful way and we’d like to support the transition away from refrigerant based distribution with education and advocacy work. The reduced refrigerant volumes of ATWHPs is a key move to decarbonizing mechanical / MEP systems.”

- Kristoff Irwin, Positive Energy
Business Science Consultant, MEP
Engineer, Owner and Principal



?
Questions?

www.spacepak.com

Air-to-water heat pumps, what are they?



AWHP Monobloc Basic Functionality

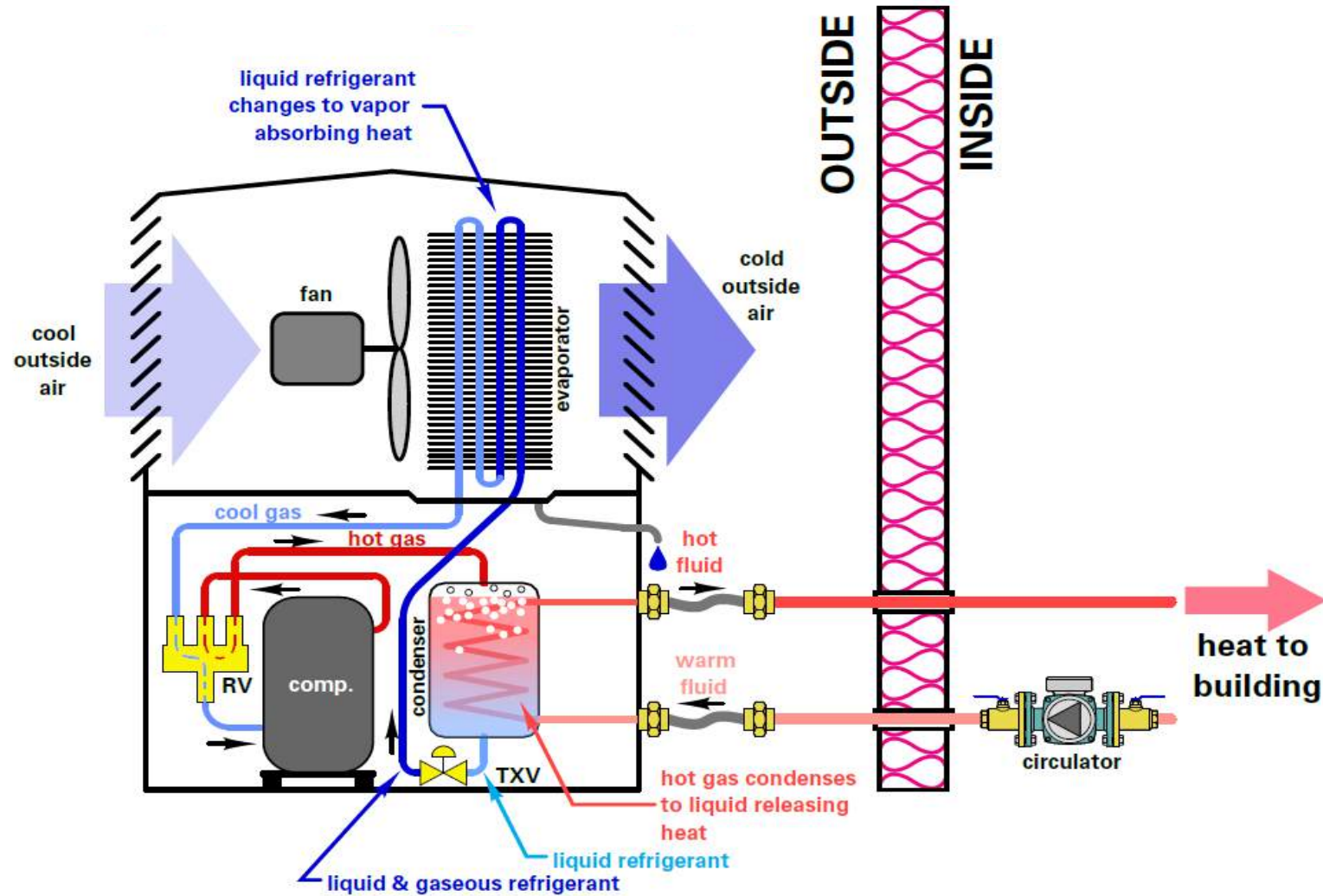

Hydronics Offer Complete System Integration

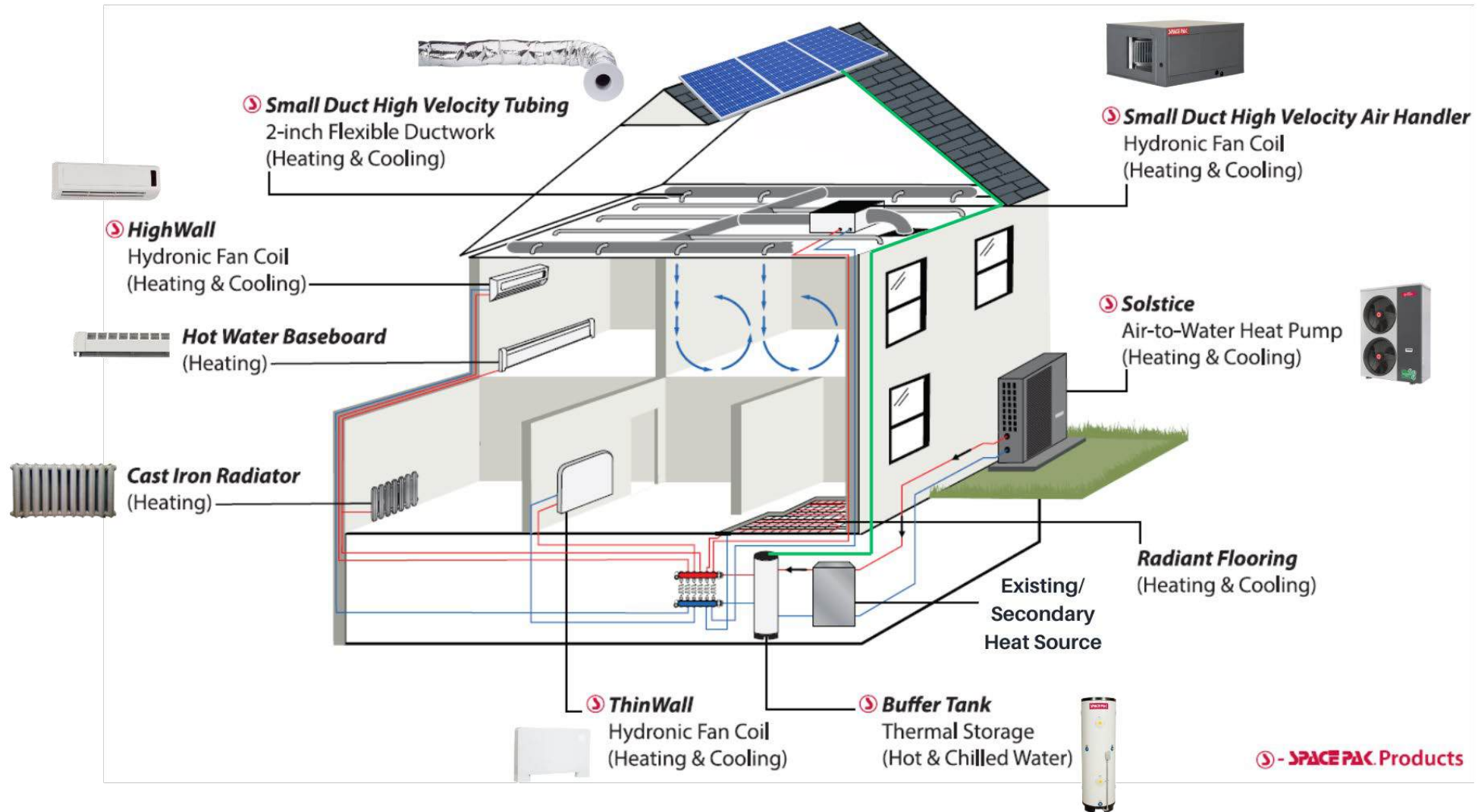

Why Water?



Ultimate design flexibility



Ease of zoning (limited only by one's ability to size systems)



Water carries more BTUs (per physical pipe size)



Integrates with existing hydronic, solar, geothermal



Partial load capabilities (vary water temperatures and flows)



Simpler maintenance - Water vs DX.. No reclaiming



Not restricted in length and lift of line set (monobloc)



Superior dehumidification

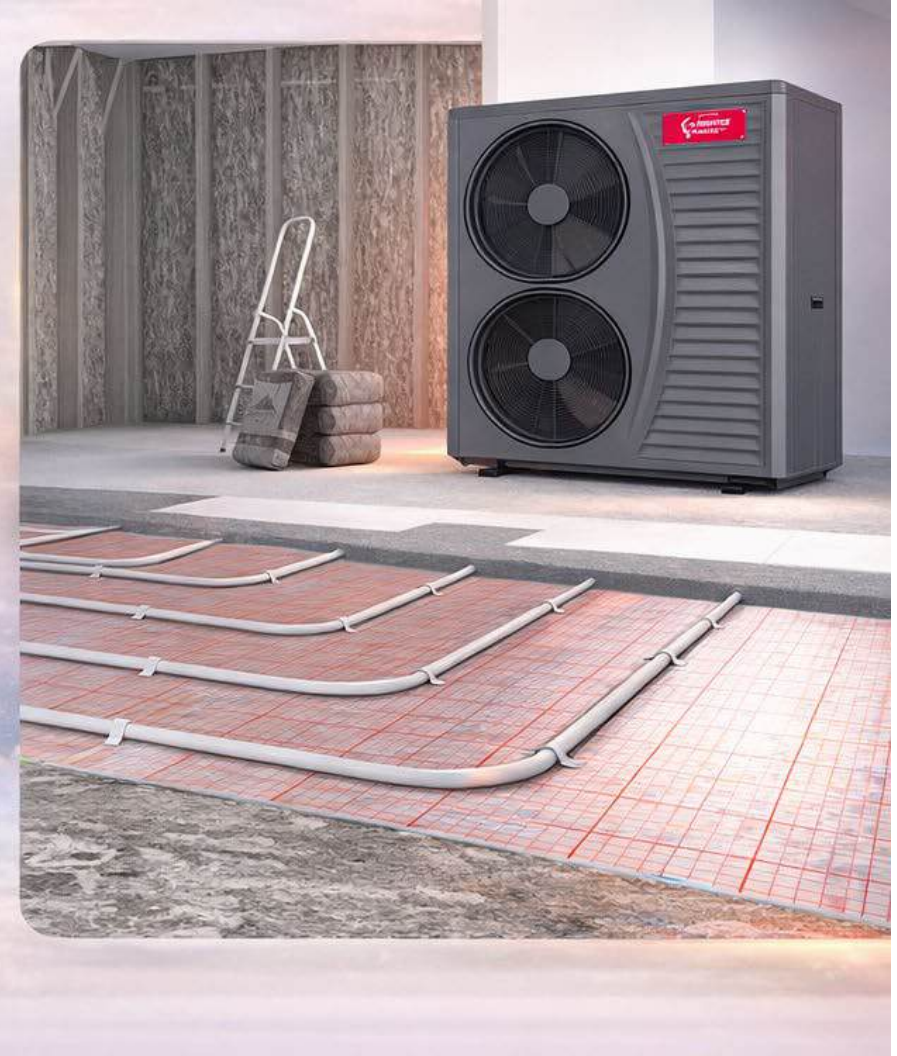

Ideal Delivered Water Temperatures for Heating

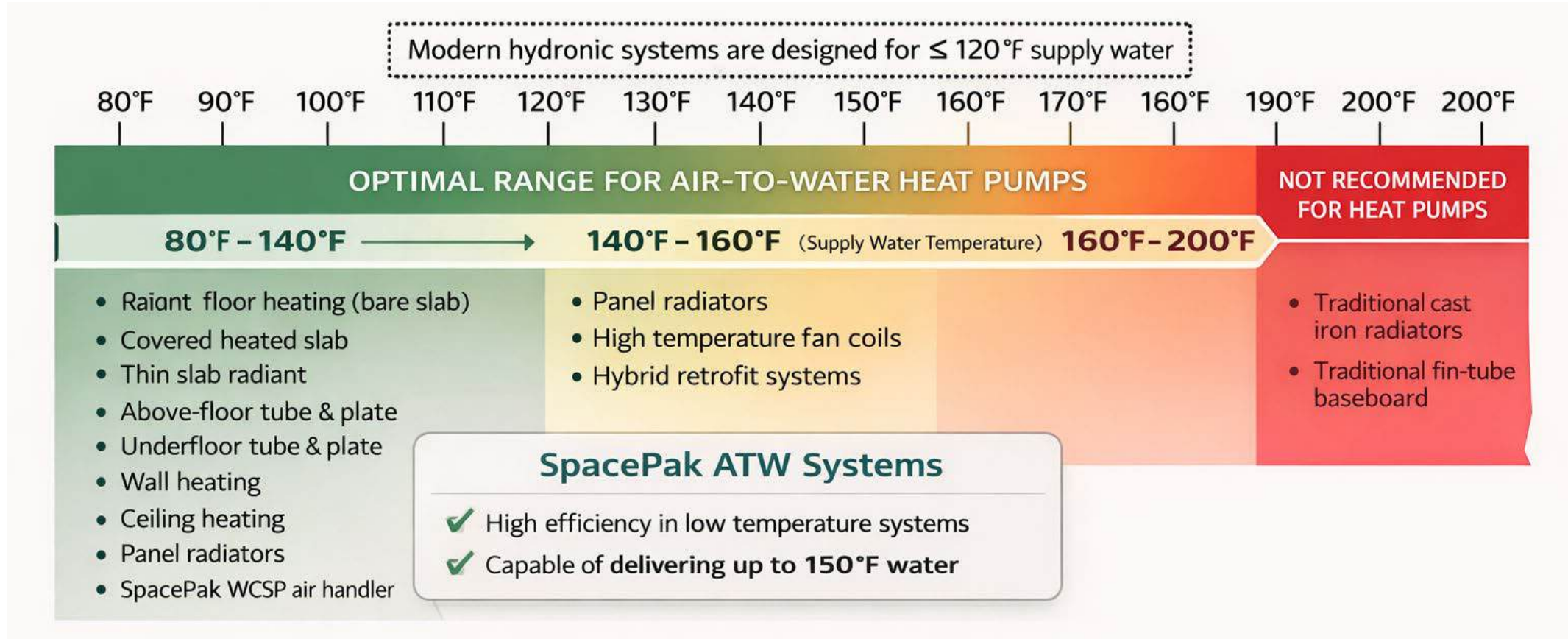

Application Examples “Versatility”

- Radiant heating/cooling
- Hydronic heating
- Forced air heating and cooling
- Centralized domestic hot water
- Snow melting
- Pool heating
- Dehumidification
 - Mushroom farms
- Process cooling
 - Milk processing & distilleries
- Projects with limited interior space
- Projects with limited exterior space
- Projects with exterior façade restrictions

Unlimited. Design. Flexibility.



Will this work in my house?

Thing to know and to be aware of

- New construction or retrofit
- Room-by-room load calculation (most important)
- Heating, cooling, domestic hot water
- Existing or desired forms of conditioning
 - Hydronic or forced air
- Existing or desired room emitters
 - Radiant, baseboard, fan coils, etc.
- Water temperature required to meet load
- Single source electric or dual fuel

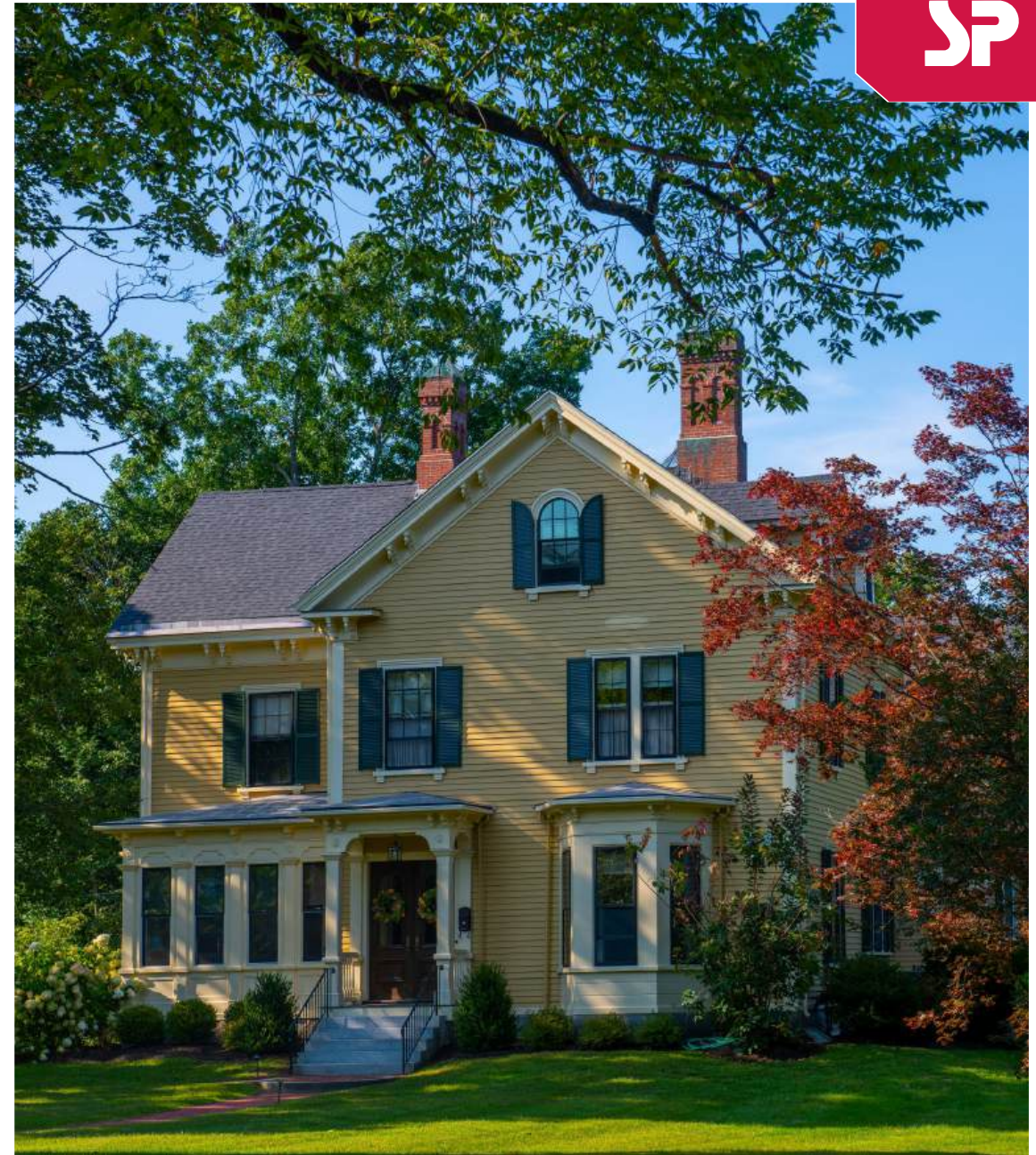



?
Questions?

www.spacepak.com

“COP” The measure of efficiency in AWHP equipment

A COP is defined as the relationship between the power (kW) that is drawn out of the heat pump as heated or chilled water, and the power (kW) that is supplied to the compressor.

With variable-speed compressors and fans, paired with properly sized buffer tanks, these units are designed to operate at peak efficiency at all times.

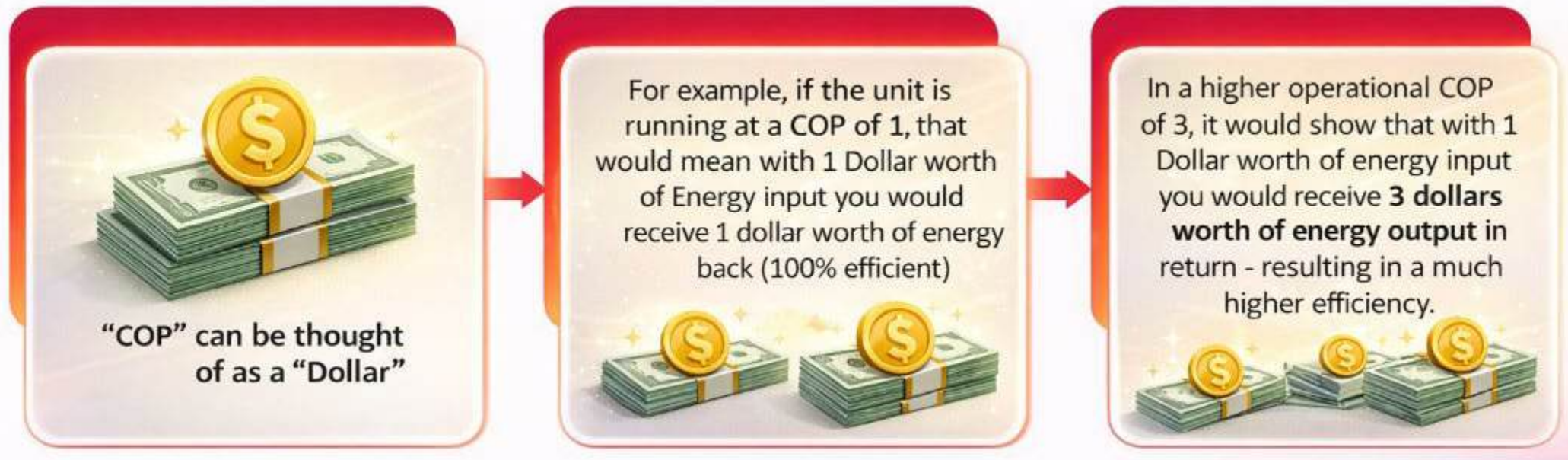

Design freedom at its finest.



A forever home should be future-proof.

Is a system truly sustainable if it's vulnerable to future regulations?

Unlike traditional heat pumps, permanent hydronic distribution systems offer a safe and environmentally friendly option, meeting the standards of both today and tomorrow.



Design freedom at it's finest.

- Heat, cool, domestic hot water from same outdoor unit
- Easy integration of thermal storage, solar and dual fuel back up
- Mix and match a variety of emitters from radiant, to ducted forced air and ductless fan coils
- Remote mount unit up to 600 ft away, on roofs, or under decks, without loss of performance
- Superior dehumidification benefit of chilled water cooling
- Unprecedented load matching
- Ideal for zoning and easy future expandability
- High performance heating down to -22°F
- Compatible with existing heating systems
- Ideal for curb appeal and historic districts
- Advanced sophistication of controls

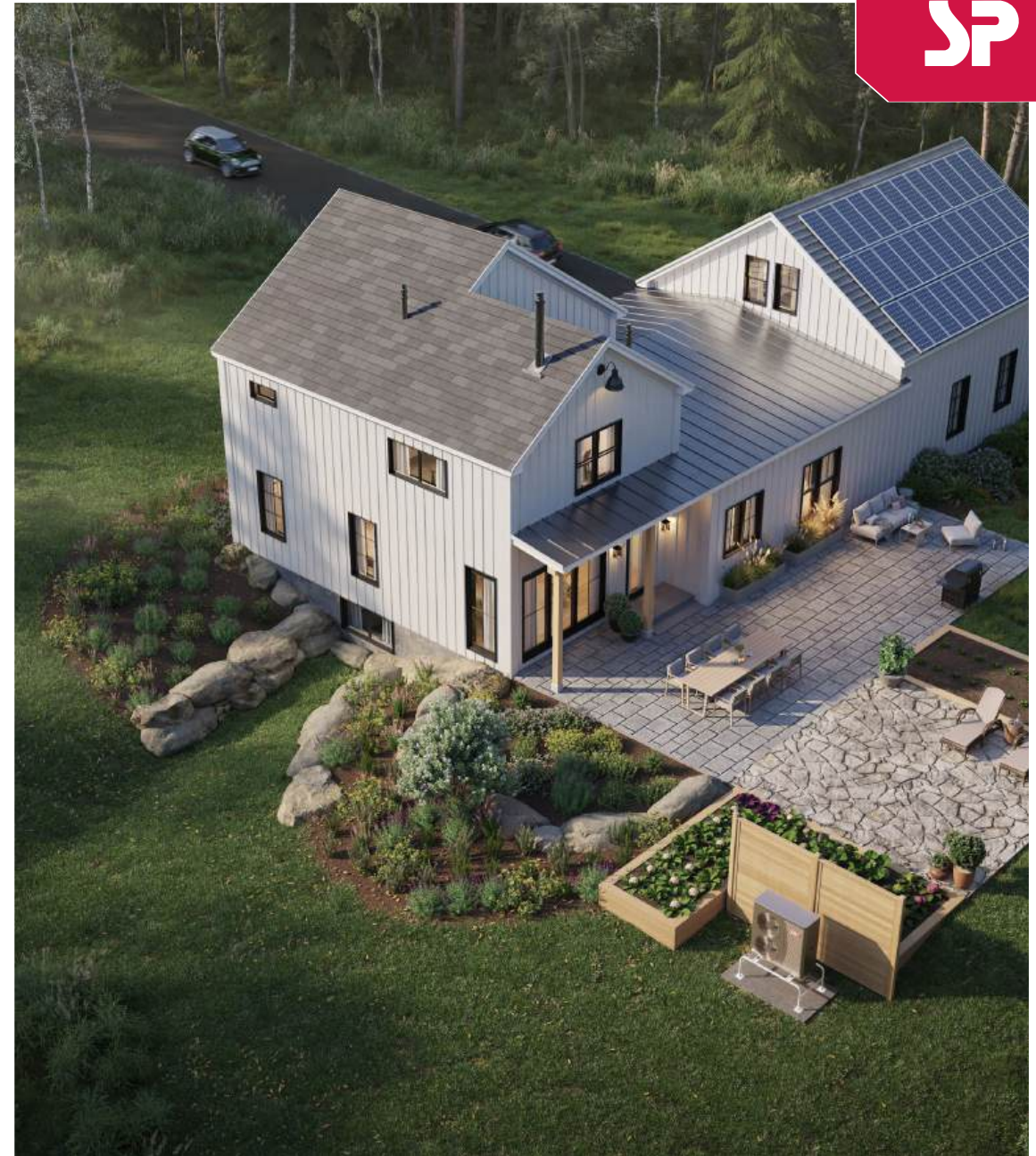

Monoblocs Offer a Future-Proof Solution



2012



2023 Upgrade

Monoblocs + Hydronics Offer Unlimited Flexibility





Example: Remote installation serving a residential hydronic system

Flexible Installation Locations

Monobloc air-to-water heat pumps allow the outdoor unit to be installed **far from the building** when needed.

Because only **water piping** enters the building, installation distance is determined by:

-  Pump sizing
-  Flow requirements
-  Pressure drop considerations

This provides **tremendous design flexibility** for challenging sites.

Up to 600 ft installation distance possible
(When properly engineered and sized)

SpacePak Full Offering



CC32-18



CC32-40



CC32-60



HT454B-40



HT454B-60

Available Early 2026 !!



TBD-R290

The future???



Solstice R32 Series (CC32)

Cold Climate Air-to-Water Heat Pump

Cold Climate Performance

- ✓ Available in 3 system sizes
- ✓ Monobloc design – eco-friendly & future-ready
- ✓ Heating, cooling, and domestic hot water capability

Extreme Cold Performance

- ✓ Reliable heating operating down to -22°F (-30°C)
- ✓ Water supply temperatures exceeding 140°F (54°C)

Environmental Advantages

- ✓ ODP = 0 (Zero Ozone Depletion Potential)
- ✓ Low GWP refrigerant (R32 – GWP 675)

Ultra-Quiet Operation

- ✓ As low as 41 dBA @ 1 meter (CC32-18)



| | CC32-18 | CC32-40 | CC32-60 |
|---------|---------|---------|---------|
| Cooling | 1.5 | 3 | 4.3 |
| BTUh | 22,827 | 41,219 | 70,461 |



Integrated system controls & monitoring

SPACE PAK

Solstice R454B Series

Cold Climate High-Temp Air-to-Water Heat Pump

HEATING • COOLING • DOMESTIC HOT WATER OFFSET

Performance & Efficiency

- ✓ Reliable delivered water temperatures up to **150°F**
- ✓ High performance heating down to -22°F
- ✓ Low GWP R454B refrigerant with reduced refrigerant volume
- ✓ Improved operating efficiencies and system performance

Advanced System Design

- ✓ Inverter-driven EVI compressor technology
- ✓ Future-proof monobloc design
- ✓ Flexible installation — unit placement up to 600 ft from building

Quiet Operation

- ✓ One of the quietest units in the market
- ✓ 43 dB(A) sound level at 3 ft

| Model Capacity | Heating Capacity (BTU/h) |
|----------------|--------------------------|
| 3.5 Ton | 8,000 - 46,000 |
| 5 Ton | 12,000 - 73,500 |



Intuitive Touch Screen Control

SPACE PAK

WarmLink App for Remote Monitoring, System Management & Support



System Monitoring

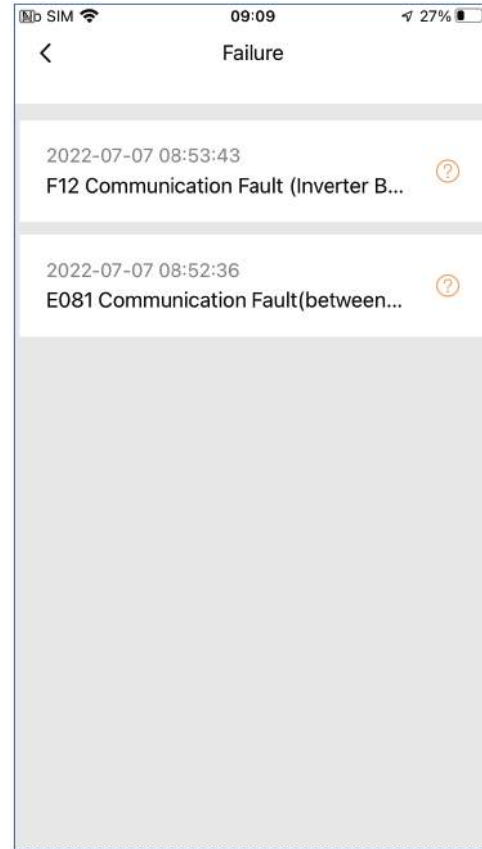

Fault Logging

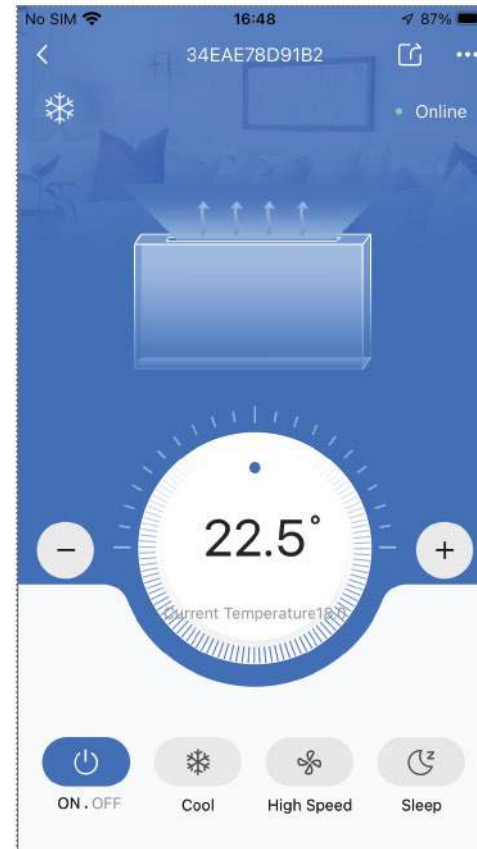

Device Management

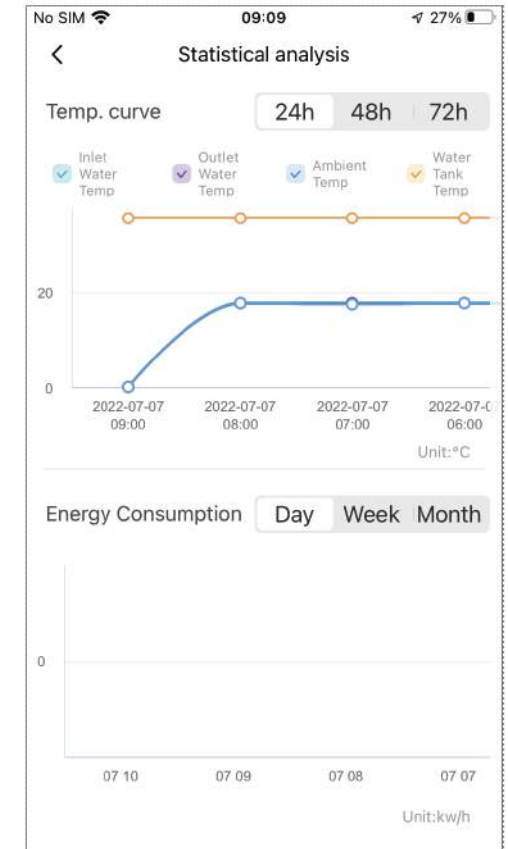

Temperature Curve Data

Stainless Steel Buffer Tanks

Built-In Electric Backup

Designed for Air-to-Water Heat Pump Systems

System Stability. Built In.

- Stabilizes system water volume
- Reduces heat pump short cycling
- Improves overall system efficiency
- Provides integrated electric backup heat

Integrated Electric Heat

- 3 kW Electric Elements Standard
- Compatible with Hot or Chilled Water Systems
- 10-Year Warranty



Built for Hydronic Performance

- 304 Stainless Steel Inner Tank
- Galvanized Steel Outer Jacket
- High-Density Polyurethane Foam Insulation
- Four-Port Open Tank Design



Available Sizes

- **13 • 26 • 40 • 80 • 119 Gallons**
- Max Flow: 36-60 GPM depending on model



HighWall Hydronic Low Temperature Fan Coil (HW)

Hydronic Heating & Cooling

- 🔹 **Hydronic Based – No Refrigerant**
- ⚙️ **High Efficiency & Performance**
 - EC Motor with Step-Less Speed Modulation
 - Auto-Swing Damper for Uniform Air Distribution
- 🔊 **Quiet Operation**
 - Whisper Quiet (33–58 dB)
- 🔹 **Cooling & Heating**
 - Operates with water temps as low as 120°F for heating
Up to 50°F for cooling
 - Stainless Steel Flexible Hose Connections
 - Condensate Drip Pans for Chilled-Water Applications
- 🛡️ **Reliability**
 - 5-Year Warranty for Certified Contractors

New look and control platform available now!

- Fan speed selection
- Thermostat compatible



- Heating Capacity: 8,100 – 25,700 BTU/h
- Cooling Capacity: 7,300 – 13,100 BTU/h

ThinWall Hydronic Low Temperature Fan Coil (HTW)

Hydronic Heating & Cooling

- 💧 **Hydronic Simplicity**
 - Hydronic-Based System – No Refrigerant
 - Operates with low water temperatures
 - Heating water temps down to 120°F
 - Cooling water temps up to 50°F

- 📺 **Modern ThinWall Design**
 - Tempered Glass Front with Touch Screen Display
 - Whisper-Quiet Operation
 - Space-Saving Slim Profile

- 🌀 **High Efficiency Air Delivery**
 - Cross-Flow Blower with Integrated Air Guiding Technology
 - ECM Blower Motor

- 🛡️ **Reliability**
 - 5-Year Warranty for Certified Contractors



- Heating Capacity: 8,700 – 32,000 BTU/h
- Cooling Capacity: 3,400 – 14,800 BTU/h

WCSP Specifications



| Model | Nominal System Capacity | | Std. CFM @ 1.2" W.C. | F.L. Amps (115V/230V) | Motor HP | Connections (CTS) | |
|--------------|-------------------------|-----------|----------------------|-----------------------|----------|-------------------|----------------|
| | Nom. Tons | Cool MBH* | | | | Water In Line | Water Out Line |
| WCSP-2430J/V | 2 | 24 | 440 | 5.6/2.8 | 3/4 | 7/8" | 7/8" |
| | 2-1/2 | 30 | 550 | | | | |
| WCSP-3642J/V | 3 | 36 | 660 | 7.6/4 | 3/4 | 7/8" | 7/8" |
| | 3-1/2 | 42 | 850 | | | | |
| WCSP-4860J/V | 4 | 48 | 880 | 10.6/5.4 | 3/4 | 7/8" | 7/8" |
| | 5 | 60 | 1150 | | | | |

* Capacities based on 45°F entering water temperature at 5 G.P.M.

Hydronics Offer Complete System Integration

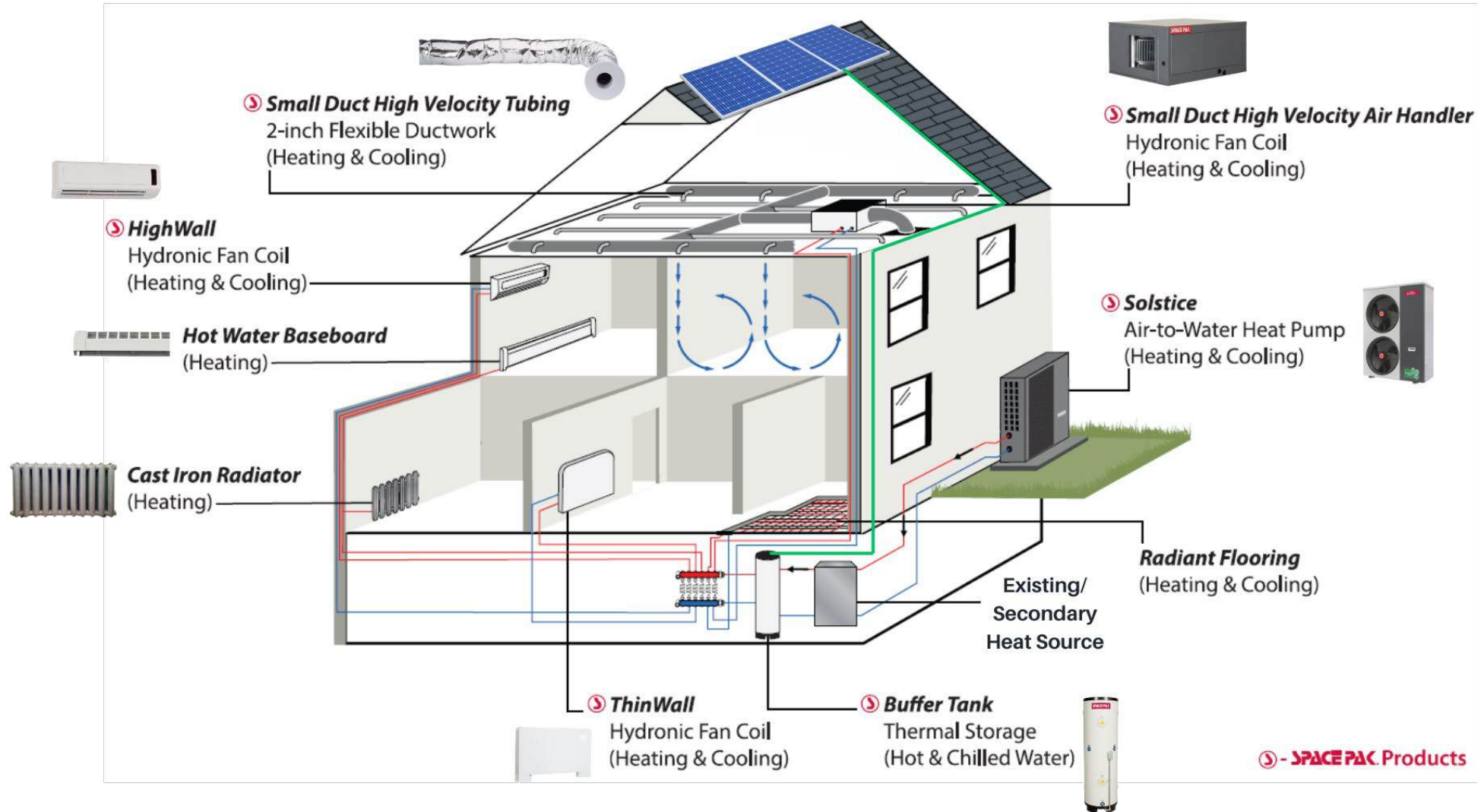

SpacePak System Interface Control (SSIC)



SIMULTANEOUS CONTROL
of Hot & Cold Storage Tanks



STAGING & UNIT ROTATION
Support for up to 20 Solstice Units











MULTIPLE RUN MODES
OA Switchover | Buffer Tank Priority | Boiler Help | Master Zone



MULTI-ZONE CAPABILITY
Up to 5 Inputs - Flexible system design

COMPATIBLE WITH

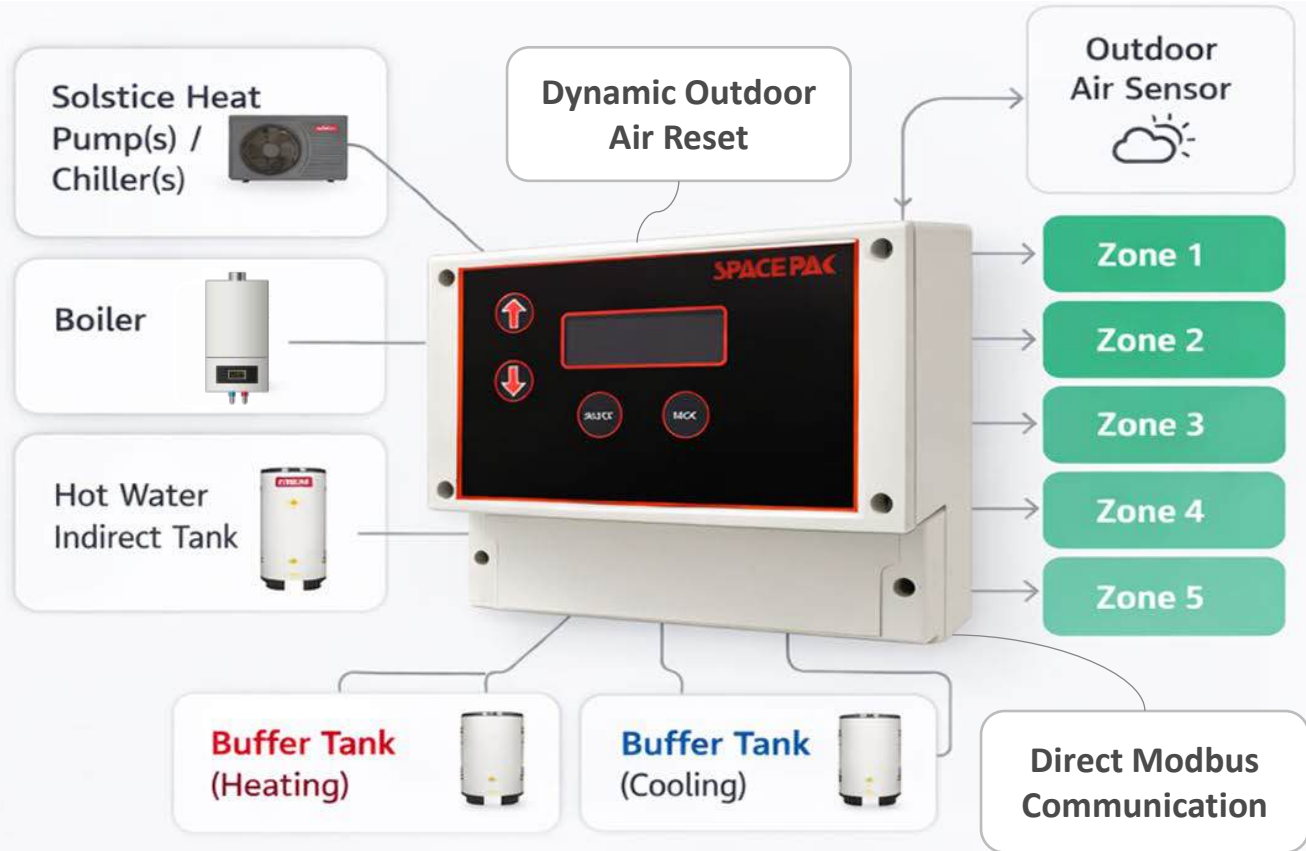
| | | | | | |
|---|---|--|---|---|--|
|  Radiant Floors / Panels |  Ducted Air Handlers / Fan Coils |  Ductless Fan Coils |  Panel Radiators |  Baseboard |  Convectors |
|---|---|--|---|---|--|





?
Questions?

www.spacepak.com

Application of key components needed for



efficient and flexible systems.

The All-Important Buffer Tank

What's the Purpose?

- Thermal storage (Heated or Chilled)
- Hydraulic separation (respect the flow)
- Optimizes system efficiency and run cycles
- Satisfy smaller loads with stored energy
- Allows proper use of on/off peak electrical demand benefits (go larger)

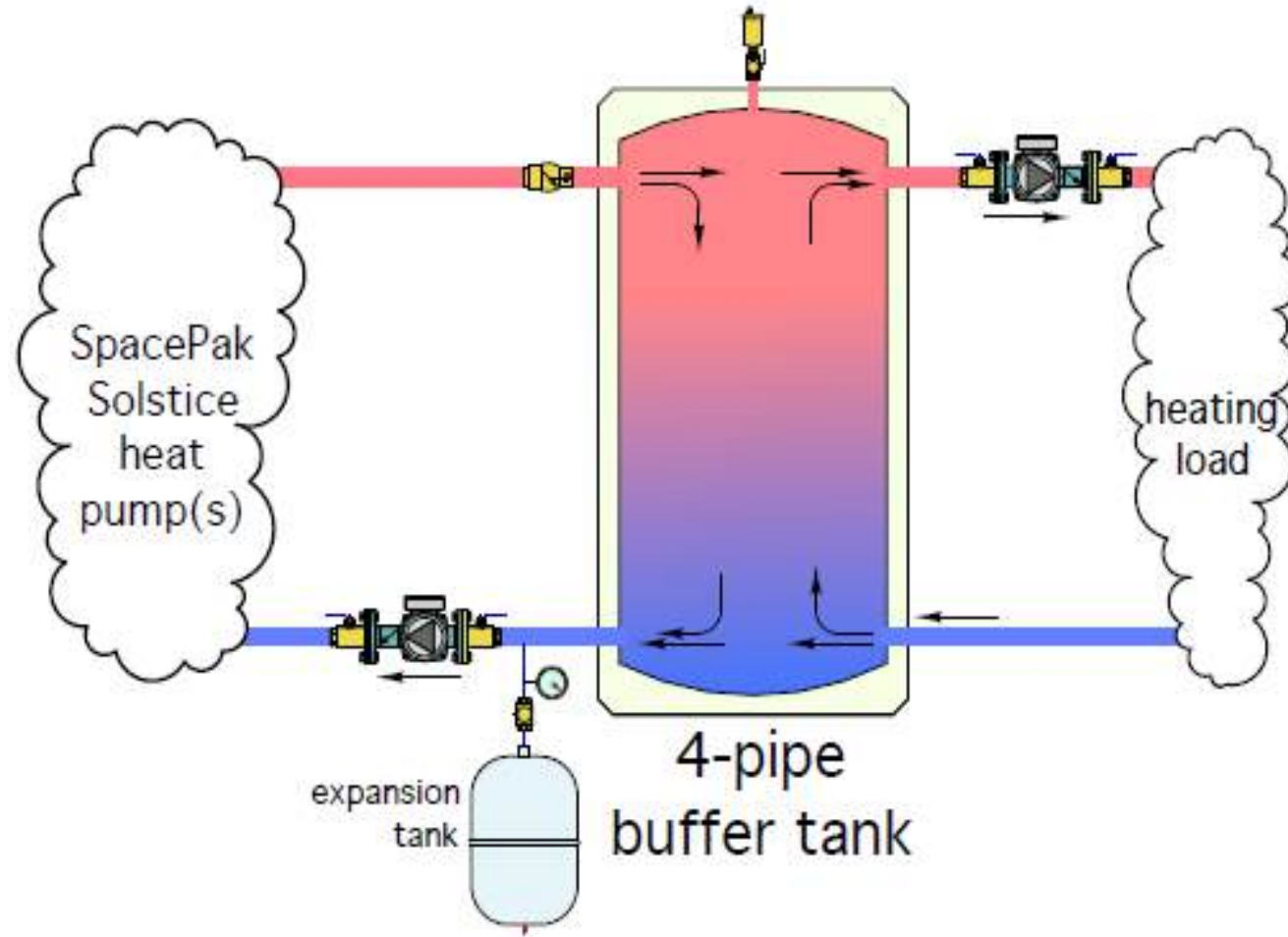

How to Size ?

Sizing – Keep it Simple

Minimum Buffer/System Volume must be equal to or greater than 7.5 gallons per nominal ton of unit's capacity at its lowest turndown (Heating or Cooling - whichever is larger)

Note: Remember to consider the “systems” capacity. In a situation where there is a large volume (Cast Iron Radiators) you may want a larger buffer to accommodate a larger inrush of “load” and to prevent temperature swings.

MIND THE FLOW !

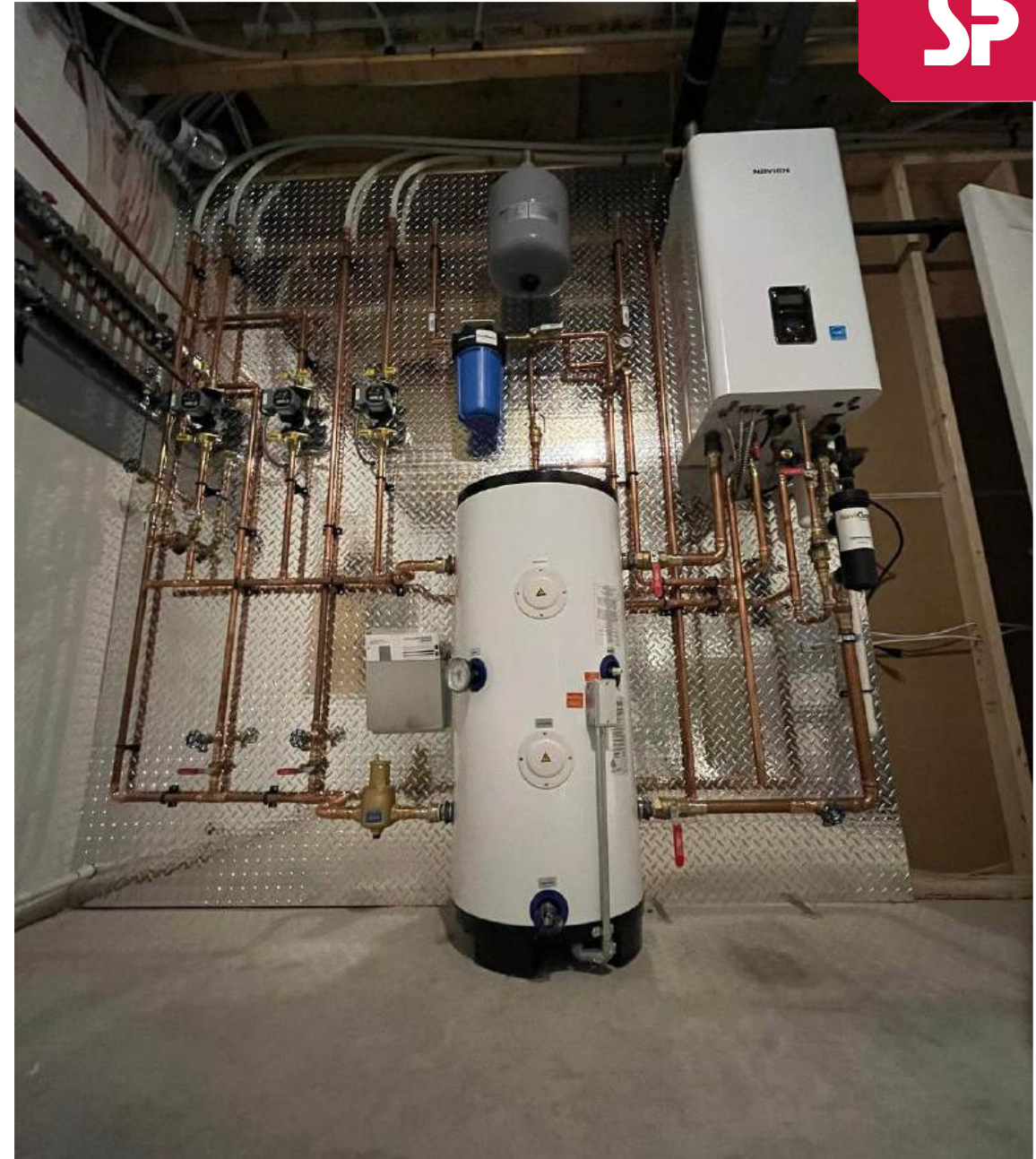

Buffer Tank Benefits

The Buffer Tank Advantage



Properly Sized System

Adequate Buffer Volume

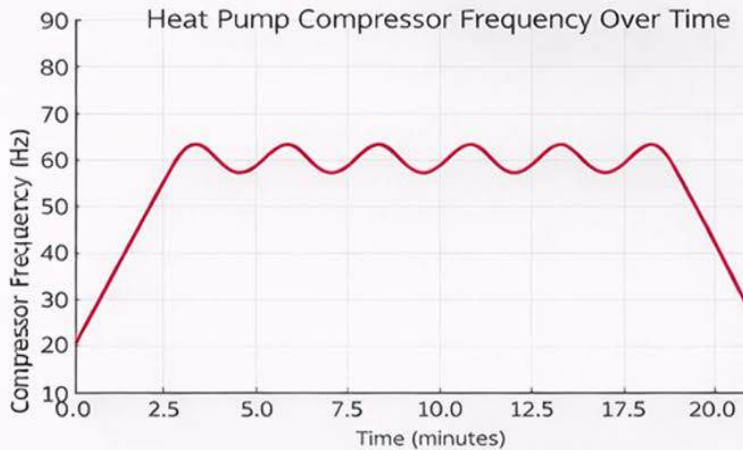

- ✓ Stable compressor modulation
- ✓ Longer run cycles
- ✓ Reduced wear on components
- ✓ Higher system efficiency

✓ **Stable Operation**

Why Buffer Tanks Matter

- ▶ Stabilize system flow
- ▶ Increase thermal mass
- ▶ Extend compressor run cycles
- ▶ Reduce short cycling
- ▶ Improve overall system efficiency



Improperly Sized System

Insufficient Buffer Volume

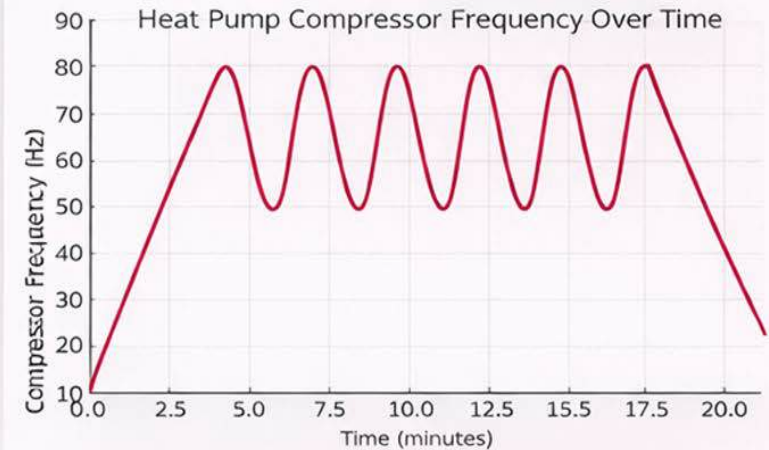

- ✗ Short cycling compressor
- ✗ Increased electrical consumption
- ✗ Reduced system lifespan
- ✗ Poor comfort stability

✗ **Short Cycling**



?
Questions?

www.spacepak.com

Single Heat Pump Applications



Basic Monobloc Heat Pump Installation

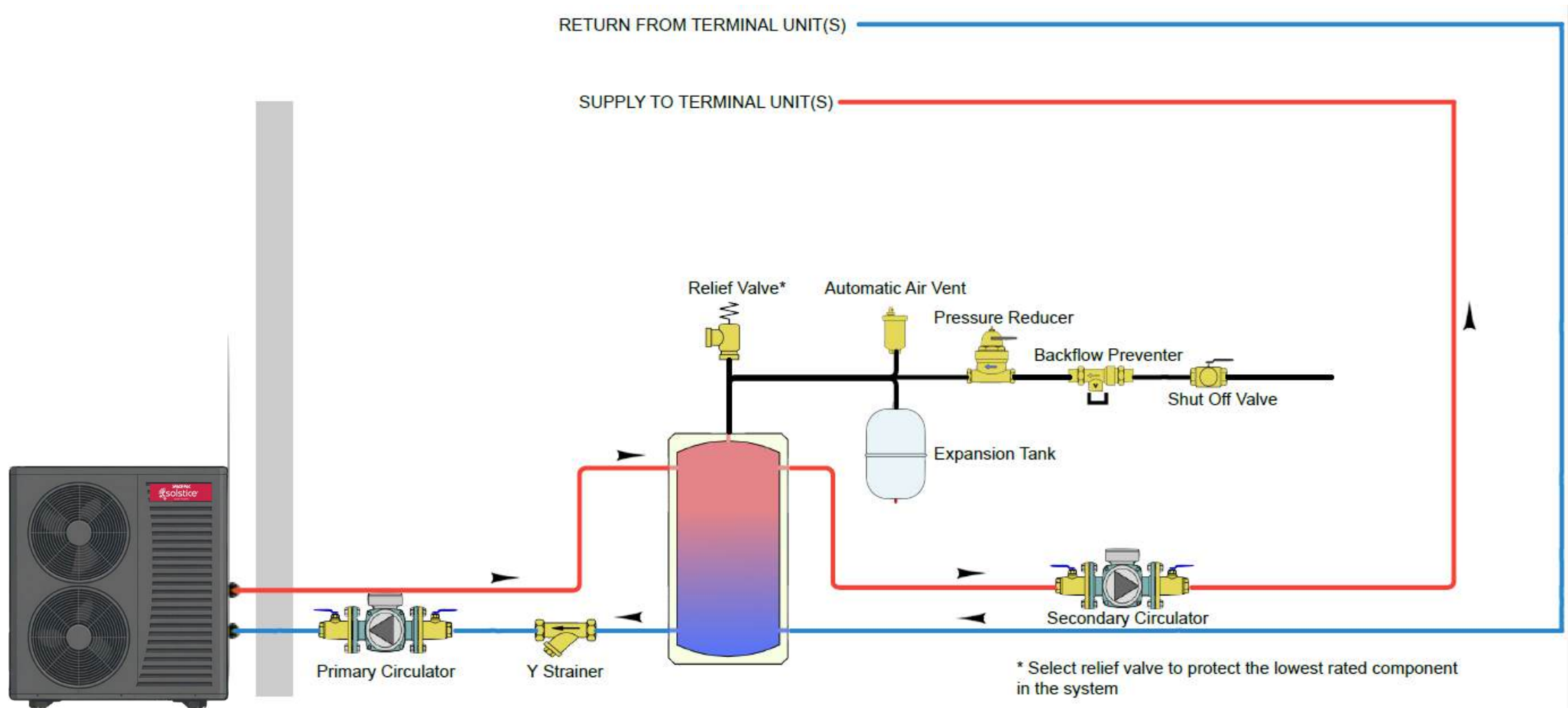

Multiple Heat Pump Applications



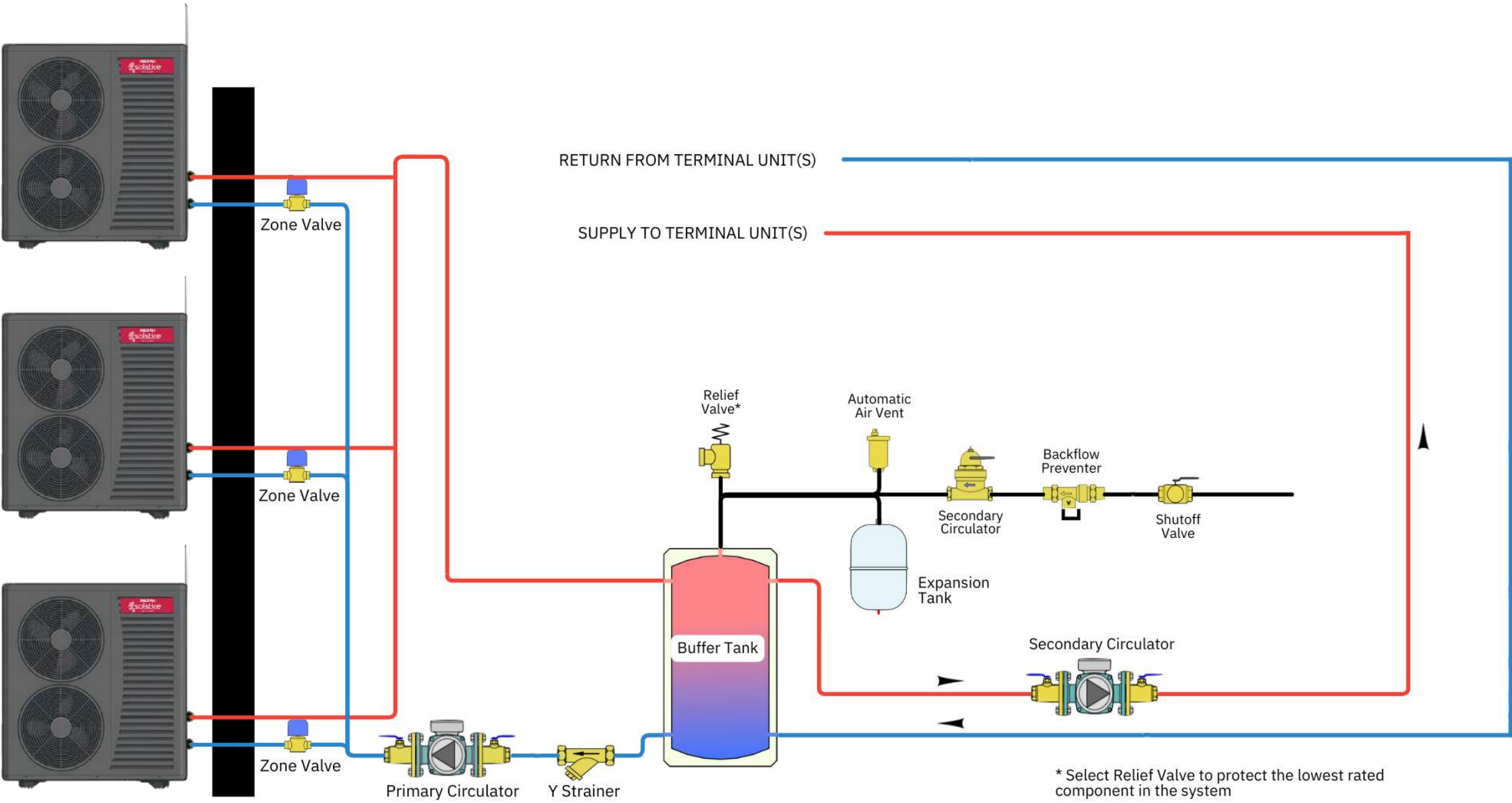

* Select Relief Valve to protect the lowest rated component in the system

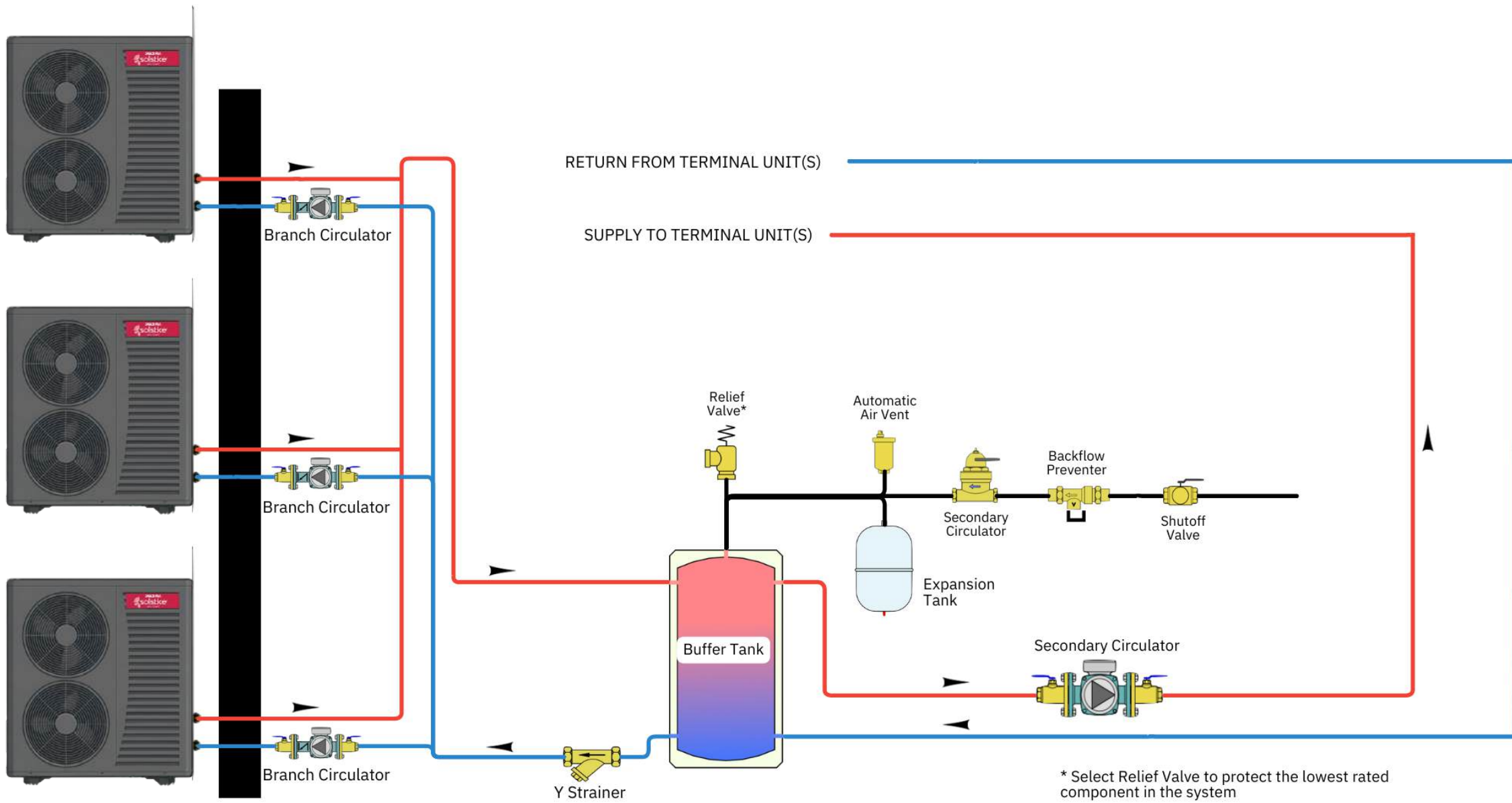

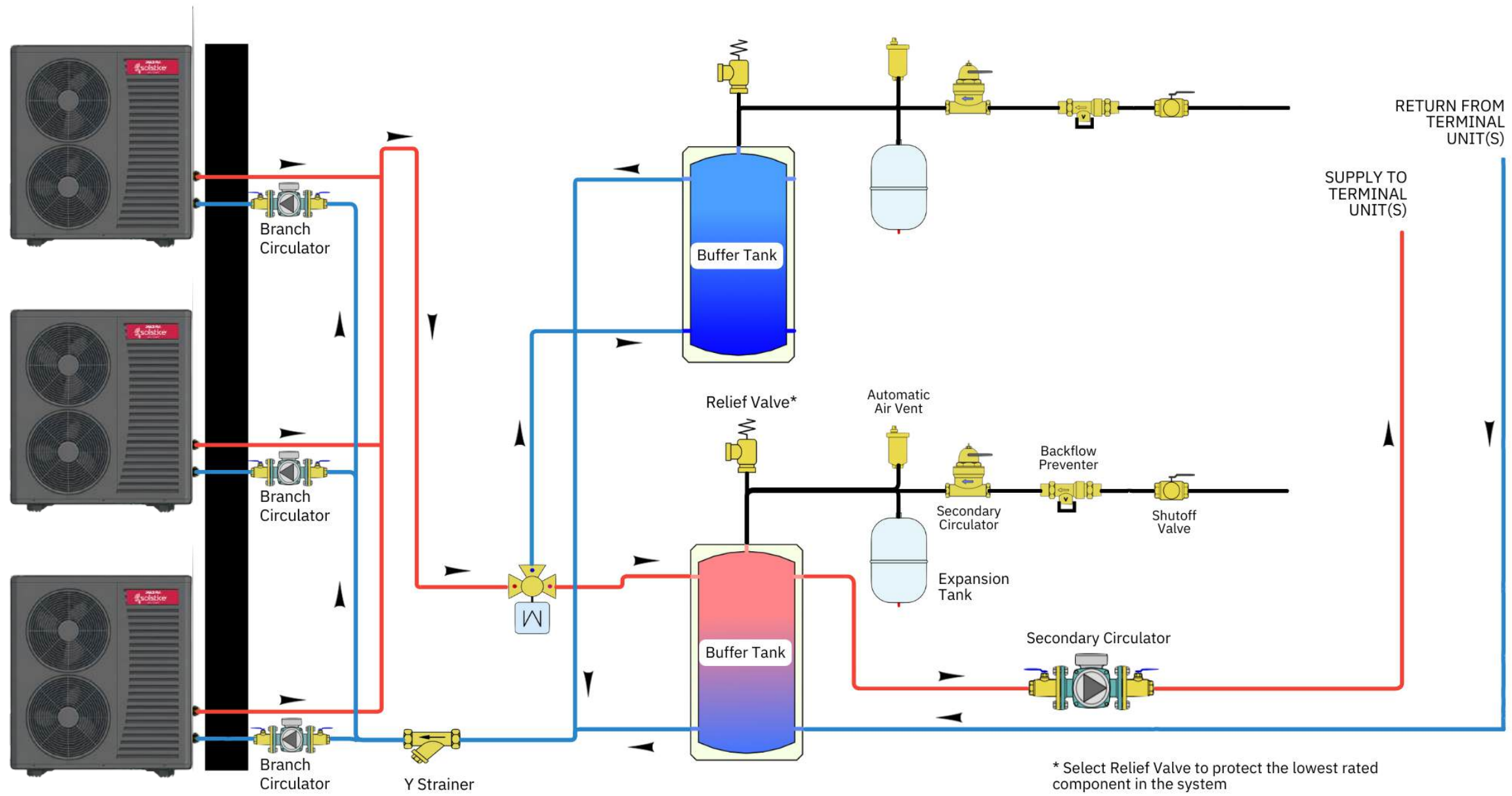

RETURN FROM
TERMINAL
UNIT(S)

SUPPLY TO
TERMINAL
UNIT(S)

Branch
Circulator

Branch
Circulator

Branch
Circulator

Y Strainer

Buffer Tank

Relief Valve*

Buffer Tank

Automatic
Air Vent

Secondary
Circulator

Expansion
Tank

Secondary
Circulator

Backflow
Preventer

Shutoff
Valve

* Select Relief Valve to protect the lowest rated component in the system

Multi-Unit Examples

For Many Reasons





?
Questions?

www.spacepak.com

Indoor Piping Basics

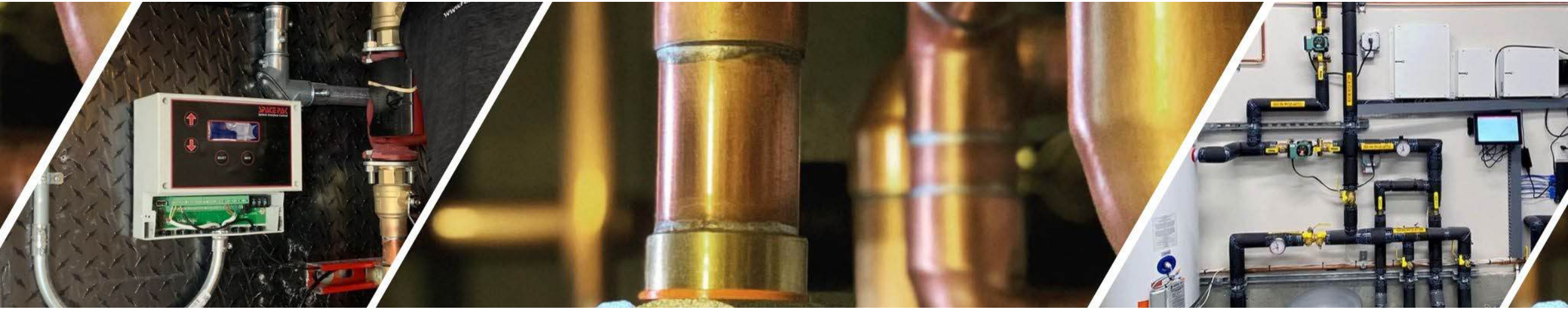

Heat Pump with Thermostatic Valve Application

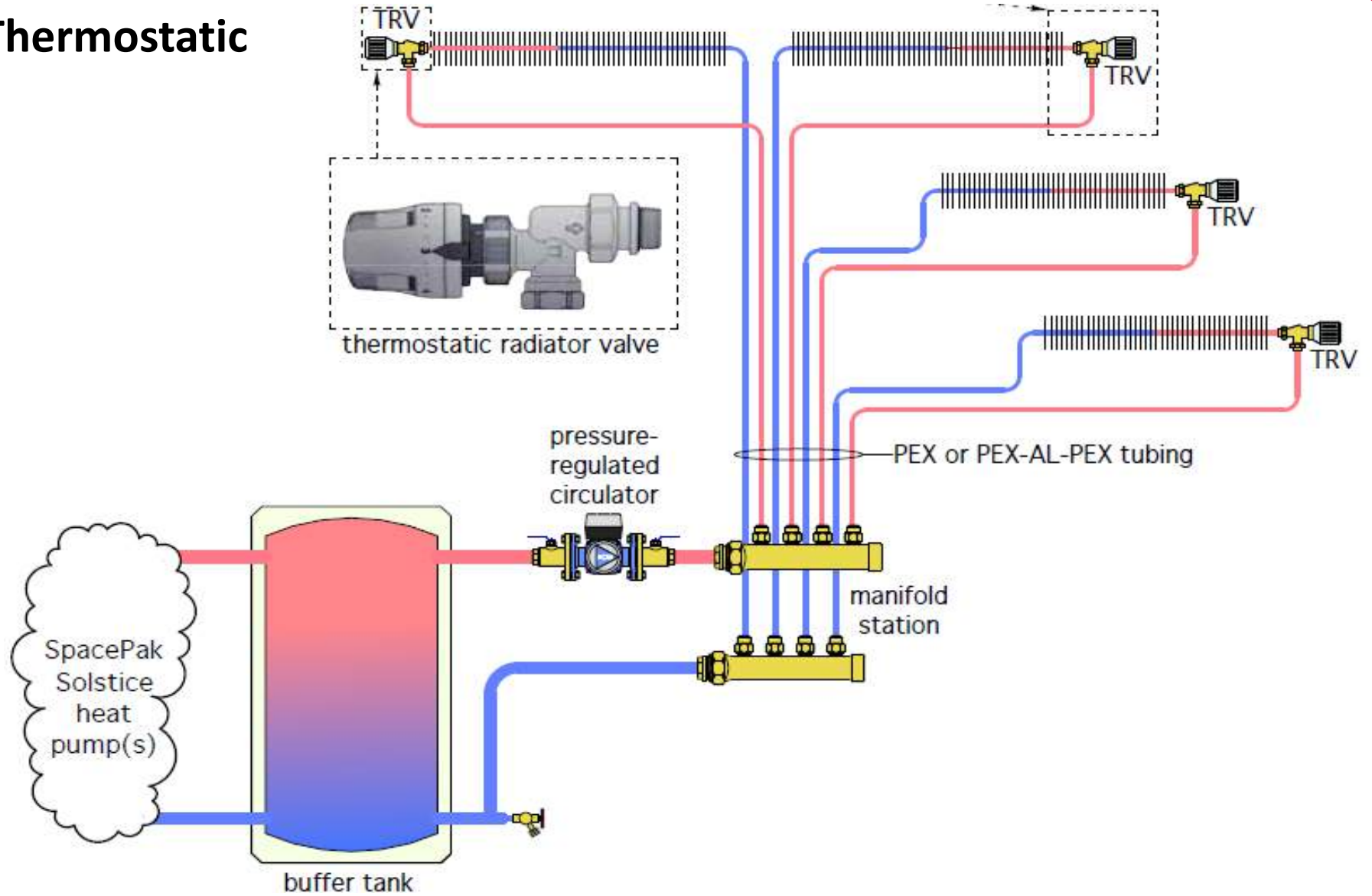

Zoned Radiant Applications

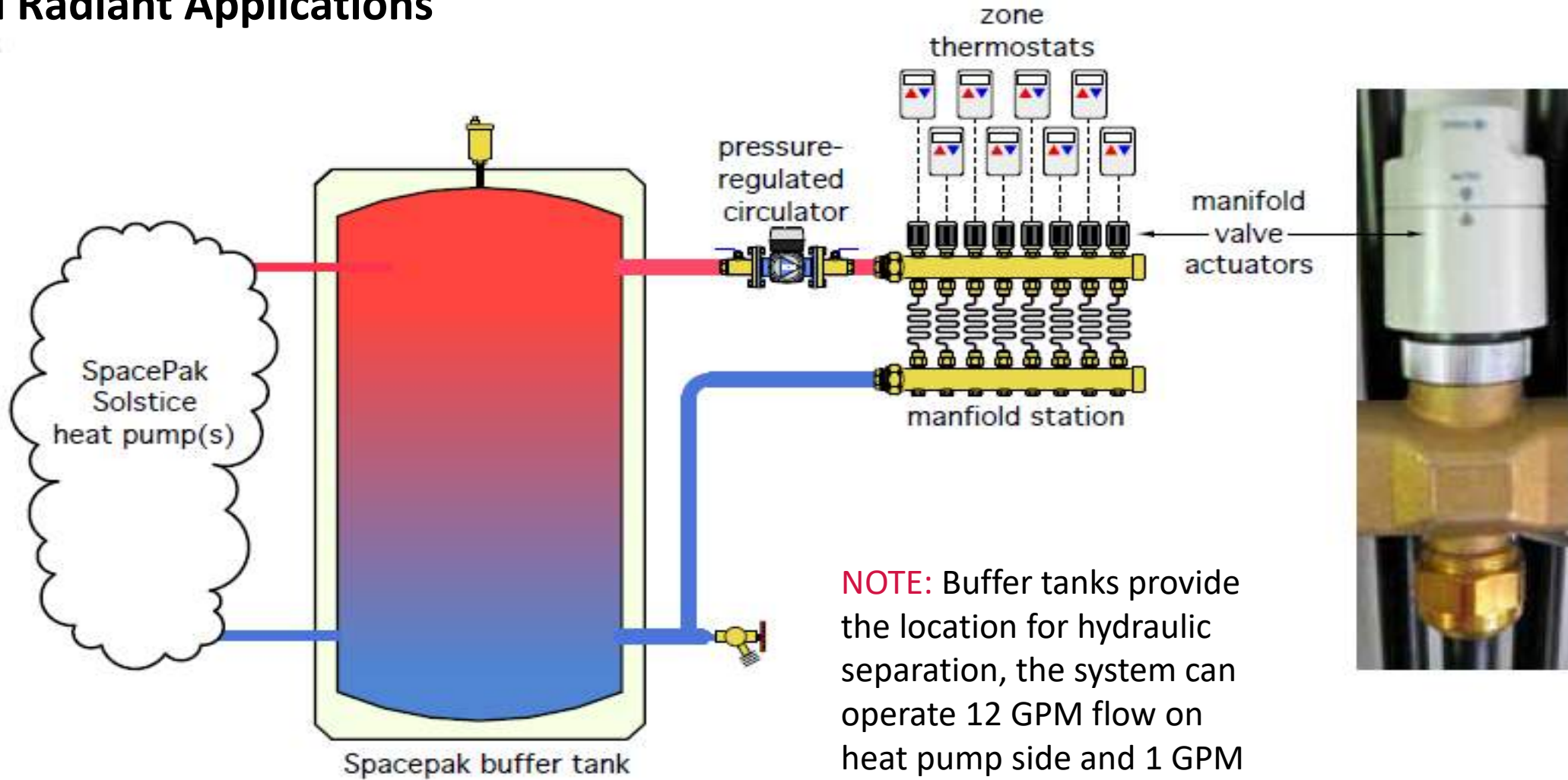

NOTE: Buffer tanks provide the location for hydraulic separation, the system can operate 12 GPM flow on heat pump side and 1 GPM on the system side.

Panel Radiators

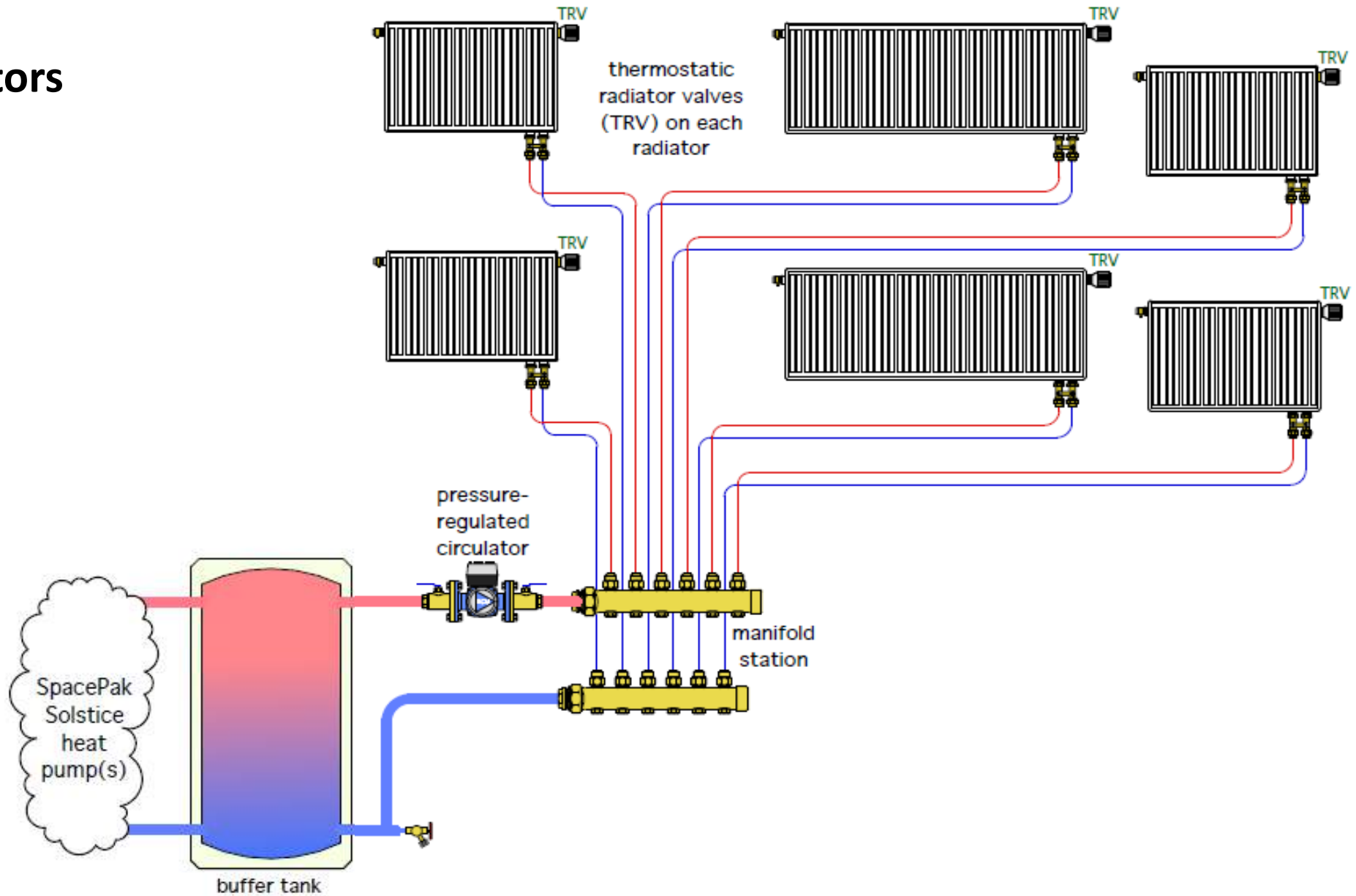

Hydronics Offer Complete System Integration (All The Benefits!)

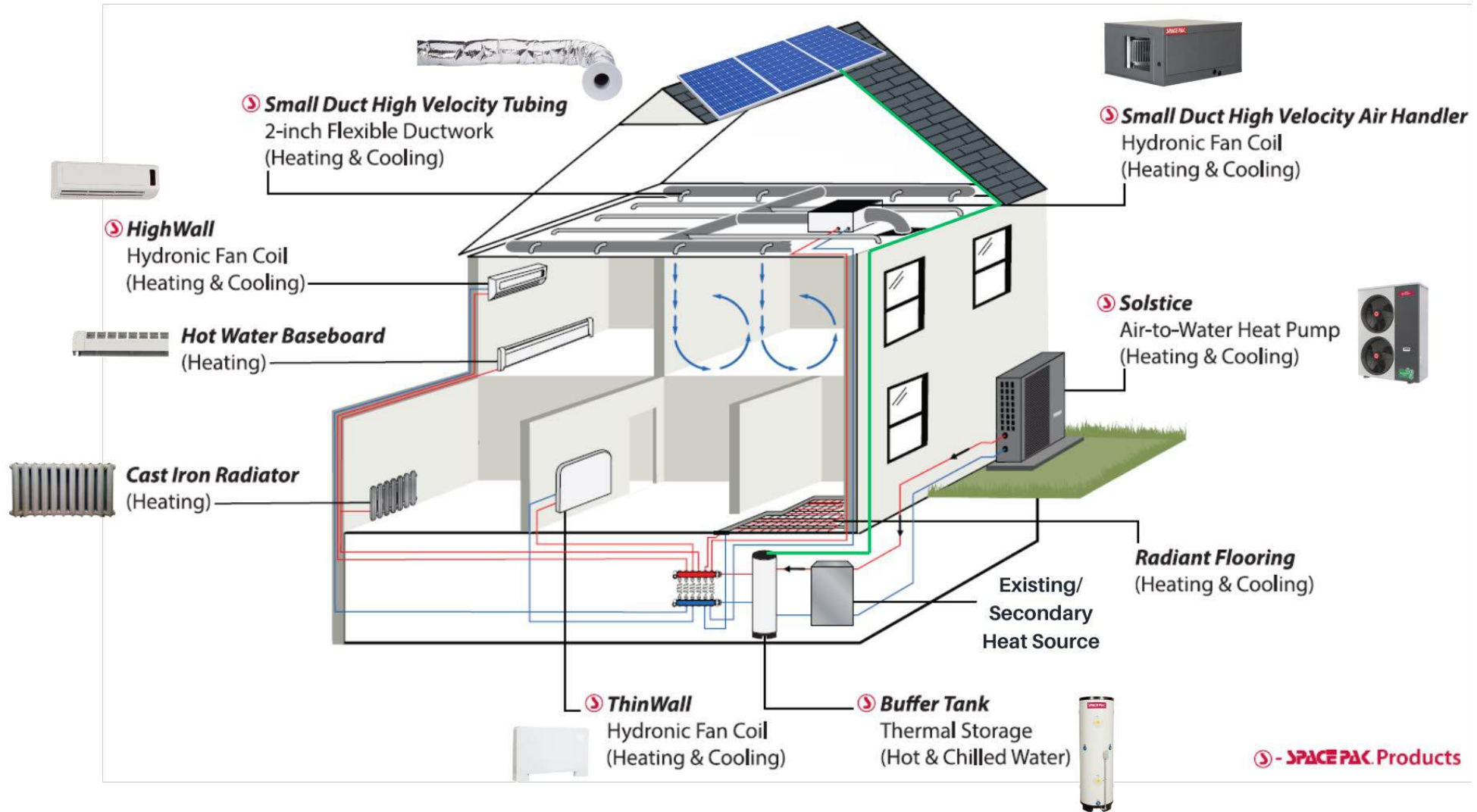



?
Questions?

www.spacepak.com

Domestic Hot Water Opportunities

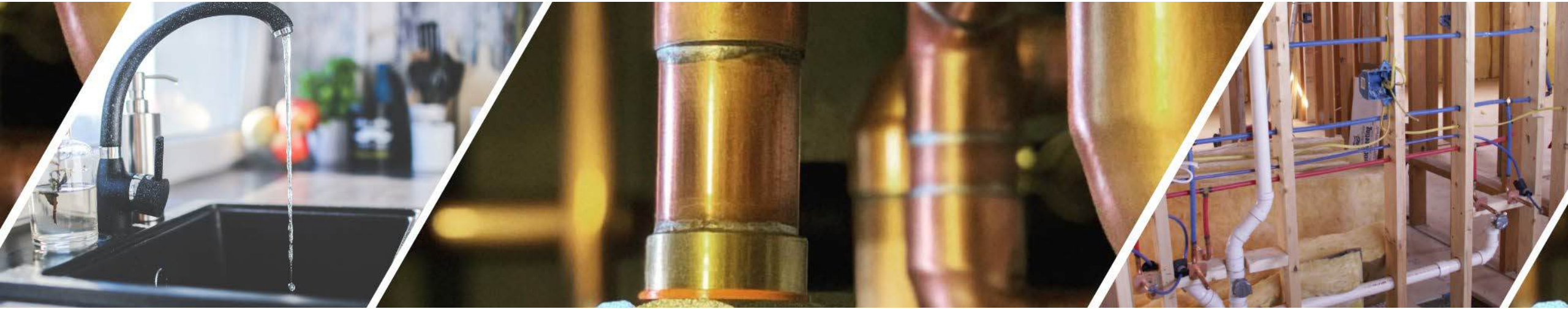

Heating + Cooling + Domestic Hot Water

- 1 HEAT PUMP
- 1 BUFFER TANK
- 1 DHW TANK

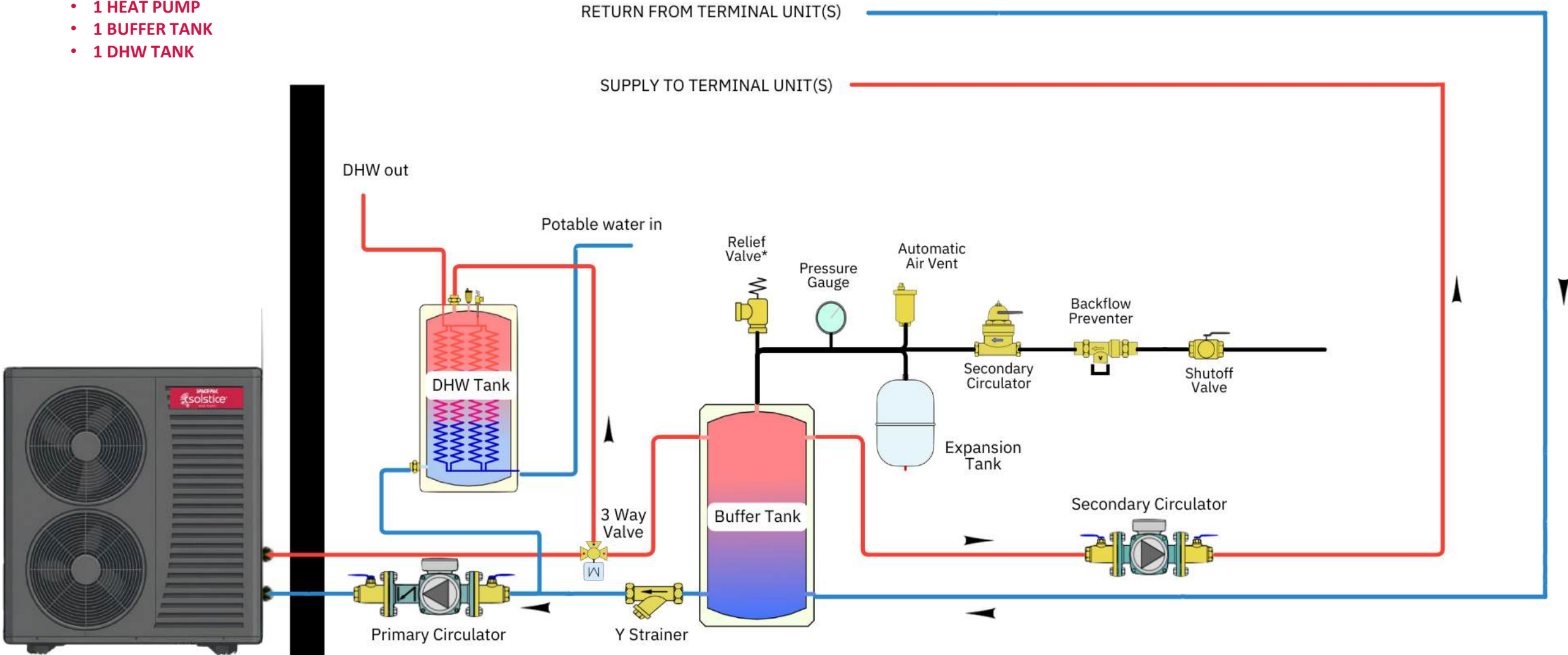

* Select Relief Valve to protect the lowest rated component in the system

Low-Temp Hybrid Reverse Style Indirect Tank

Thermal Storage Buffer Tank for Low Temperature Space Heating + up to 100% Domestic Hot Water

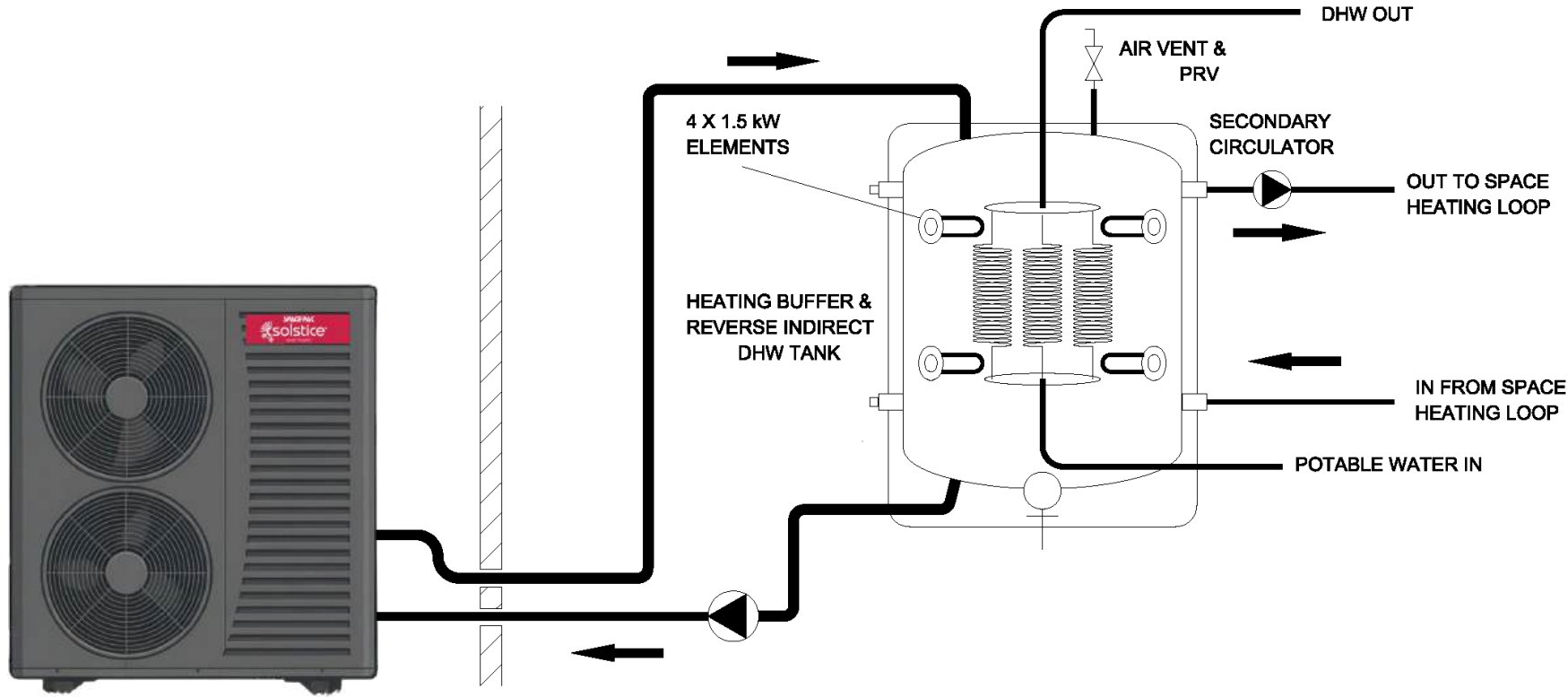

Coming Soon

Radiant Heating & Cooling HW Preheat and 2 Buf

- Simultaneous heating and cooling
- Dehumidification
- Single control platform

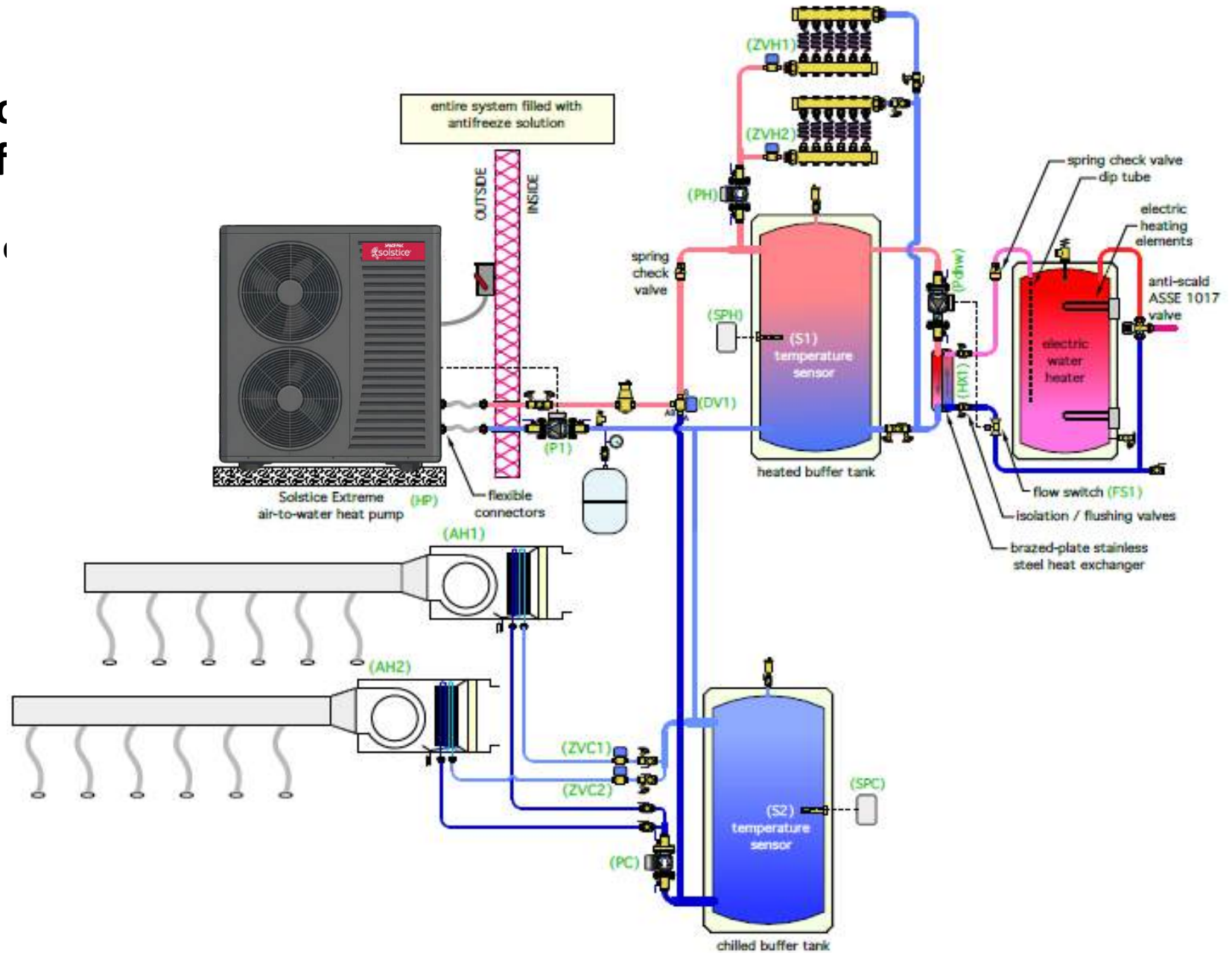

Opportunities for Hybrid “Dual Fuel” Hydronic Systems



Hydronic systems can be used with many energy sources

- Two or more of these heat sources can be combined and share the heating or cooling load based on the most favorable operating conditions for each source.
- This type of flexibility and design freedom is not afforded with traditional air source (VRF)
- Flexibility is favorable for all navigating changing energy policies and regional utility considerations

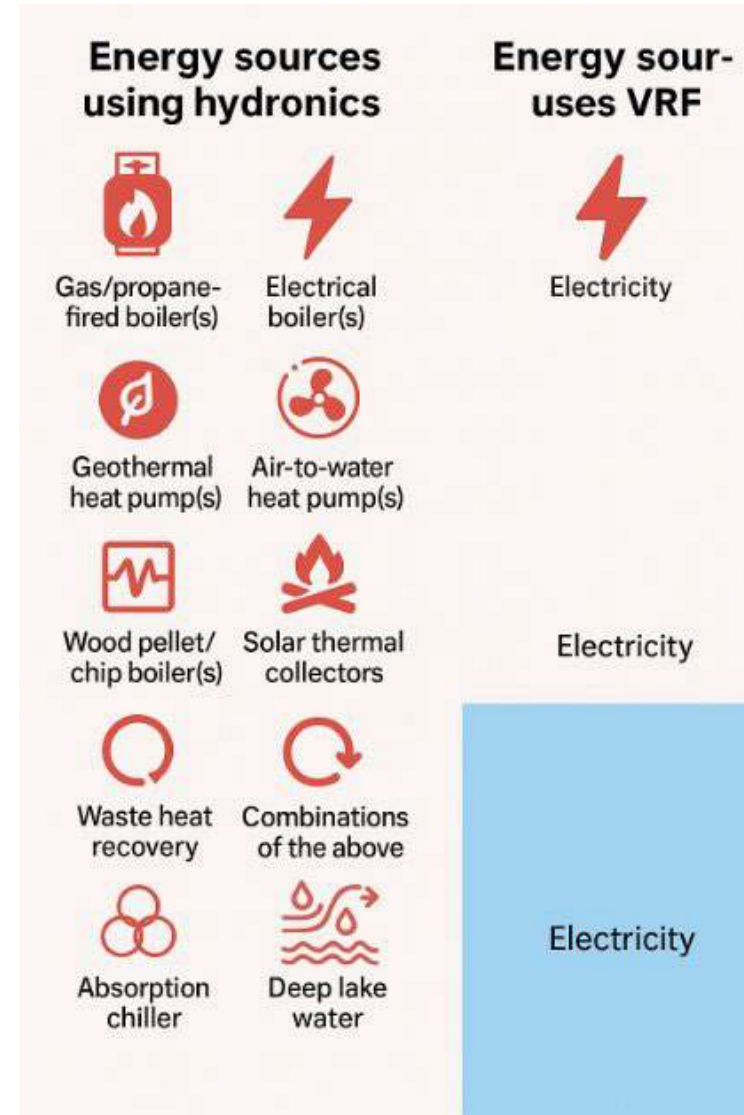

Bridging the Gap with Fuel Flexibility

Practical Considerations from the Field

- Early electrification efforts focused heavily on fully electric solutions
- Real-world performance data is reshaping the electrification conversation
- As more field data accumulates, a hybrid systems approach is increasingly proving to be the most practical, feasible, and resilient path forward
- Combining heat pumps with supplemental fuel sources can deliver greater reliability, efficiency, and long-term sustainability
- AWHP lend themselves perfectly to pairing with new or existing heating sources, providing maximum flexibility while still advancing decarbonization goals, and driving adoption at a larger scale



Heat Pump With Backup Heat (Oil/Electric/Propane)

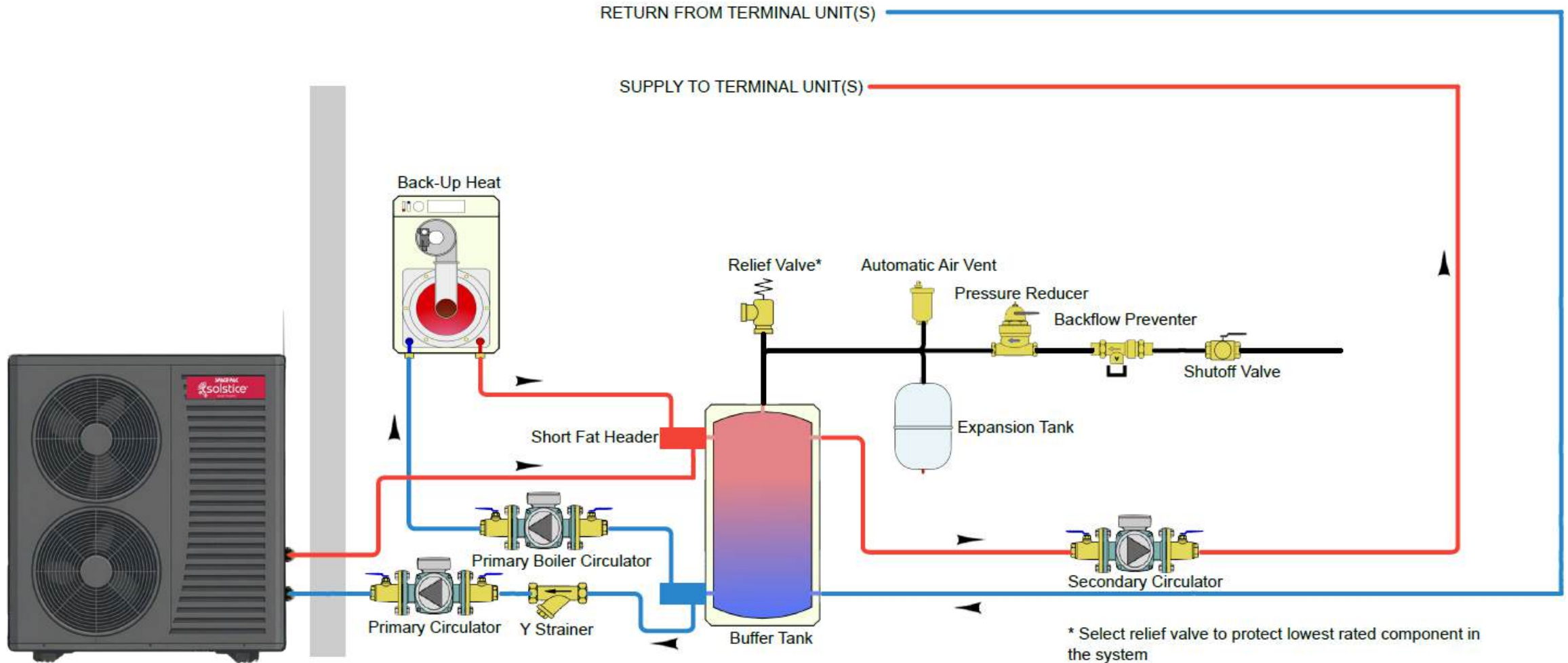











Washington State



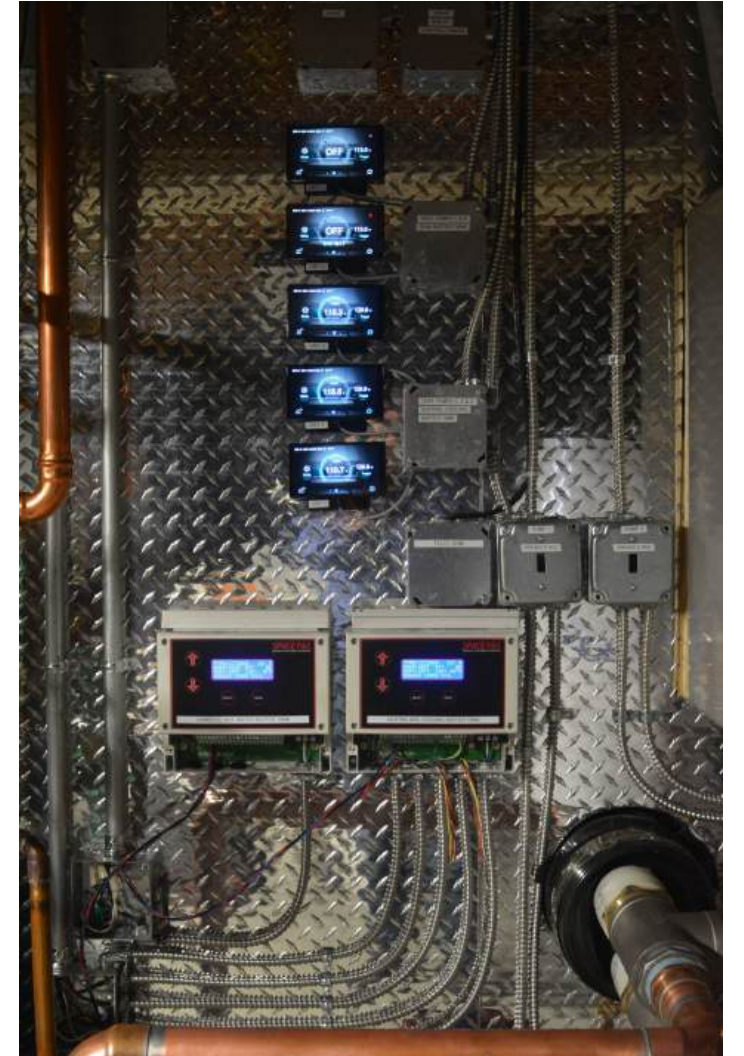

Looking Ahead

- Education & training on the endless application opportunities AWHP creates
- Continued contractor support
- Higher efficiencies, practical applications, hybrid systems, thermal storage, affordability
- Along with our Distribution, Contractor and Efficiency partners we will continue to do all we can to further the growth of this future-proof technology

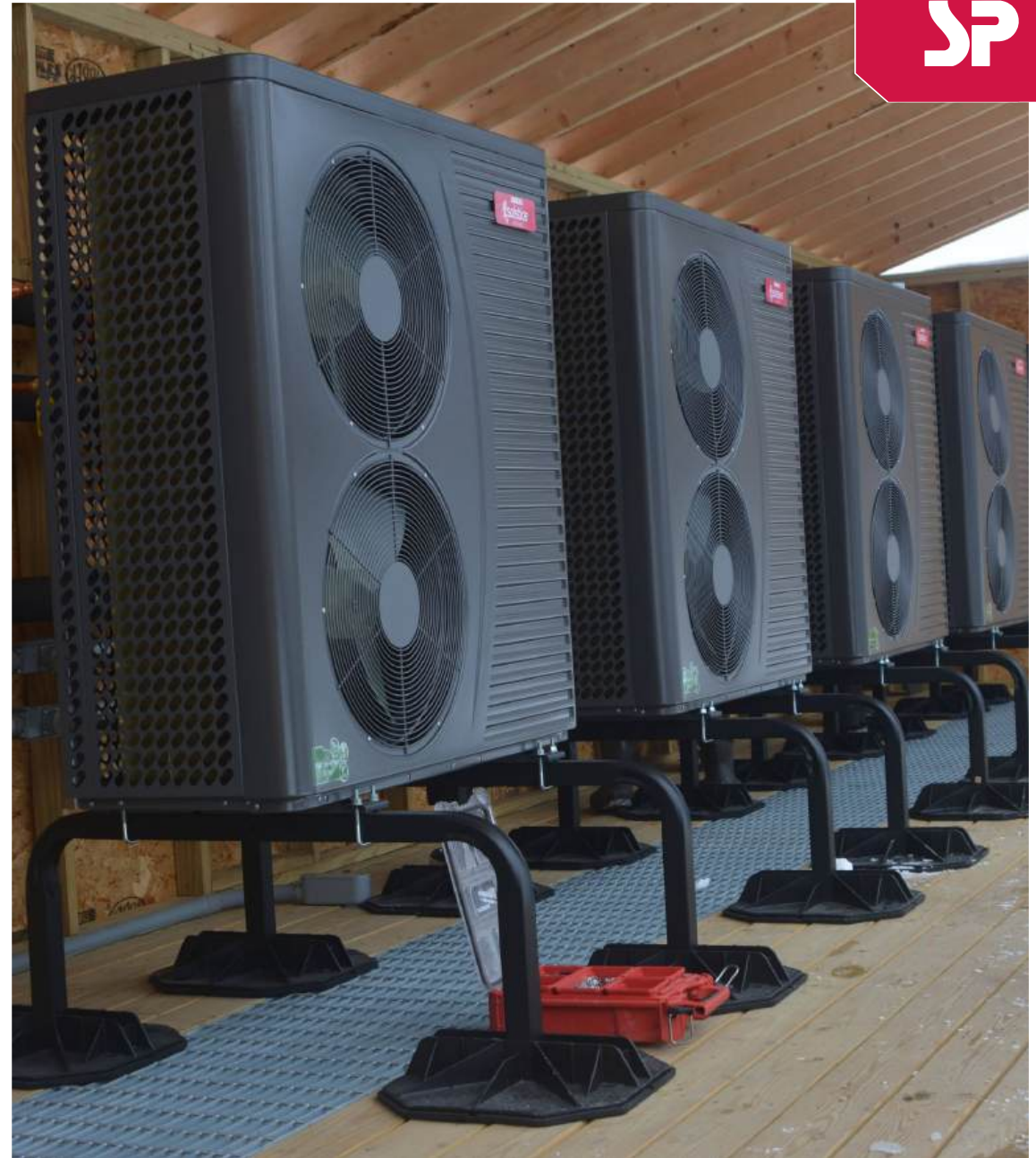

Questions?



SPACEPAK®

Thank you!
