



Transitioning to Low-Temperature Hydronic Heating

Presented by: Doug Andrade and Mark LaFrance

April 2, 2026

Hosted by:



Delivering Real Success®



We are: HVAC Manufacturer's Representatives & a Building Automation contractor

AHUs (catalogued – modular – full custom), ERVs, Chillers, ASHP & WSHP Chillers, Fans, Lab exhaust, Lab energy recovery, pre-fab plants, terminal equipment, humidification, air purification, etc.

www.hts.com

Specialized in VRV/VRF, ASHPs, VRV driven ERVs and AHUs, VRV controls

www.dxseng.com

Largest Daikin VRV rep in North America!

Building automation, energy and emissions monitoring and reporting, fault detection systems, and lab energy recovery controls

www.controltechinc.com



Doug Andrade

HTS New England

New Hampshire Technical Institute – Mechanical Engineering Technology

Core role at HTS is working as the Heating Product Specialist

Likes music and classic cars



ML1

Mark LaFrance

HTS New England

University of New Hampshire - Mechanical Engineer

Core role at HTS is supporting Consulting Engineers with HVAC equipment applications

Likes long walks at HVAC trade shows, and cars

Agenda

- **Part 1 – Where are we going, why, and how do we get there?**
- **Part 2 – Limitations of existing heating systems**
- **Part 3 – Making the transition from high-temp to low-temp**
- **Part 4 – Deeper dive into low-temp HW terminal equipment**



Before we start!

Temperature Definitions

- **High-temperature** hot water: 160-200F (Typical: 180F)
- **Medium-temp** hot water: 130-150F (Typical: 140F)
- **Low-temp** hot water: 100-120F (Typical: 120F)



Agenda

- **Part 1 – Where are we going, why, and how do we get there?**
- Part 2 – Limitations of existing heating systems
- Part 3 – Making the transition from high-temp to low-temp
- Part 4 – Deeper dive into low-temp HW terminal equipment



Existing Buildings

An estimated 70% of buildings in Boston were designed to use high-temp HW

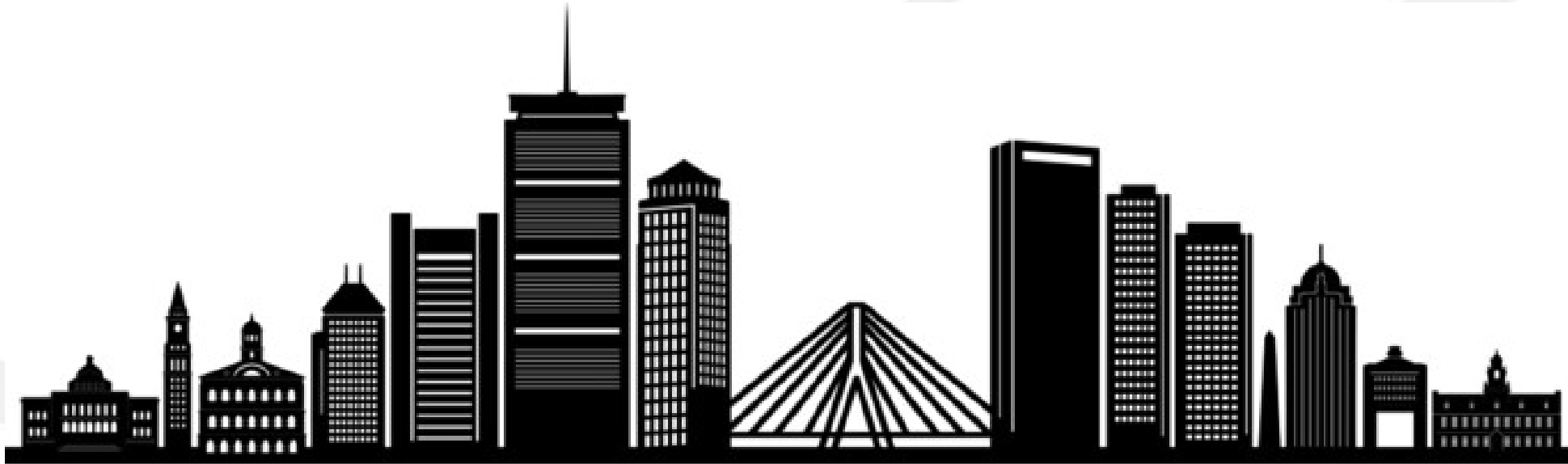

Existing Buildings

80% of the predicted building stock for 2050 are buildings that exist today

These exist today!

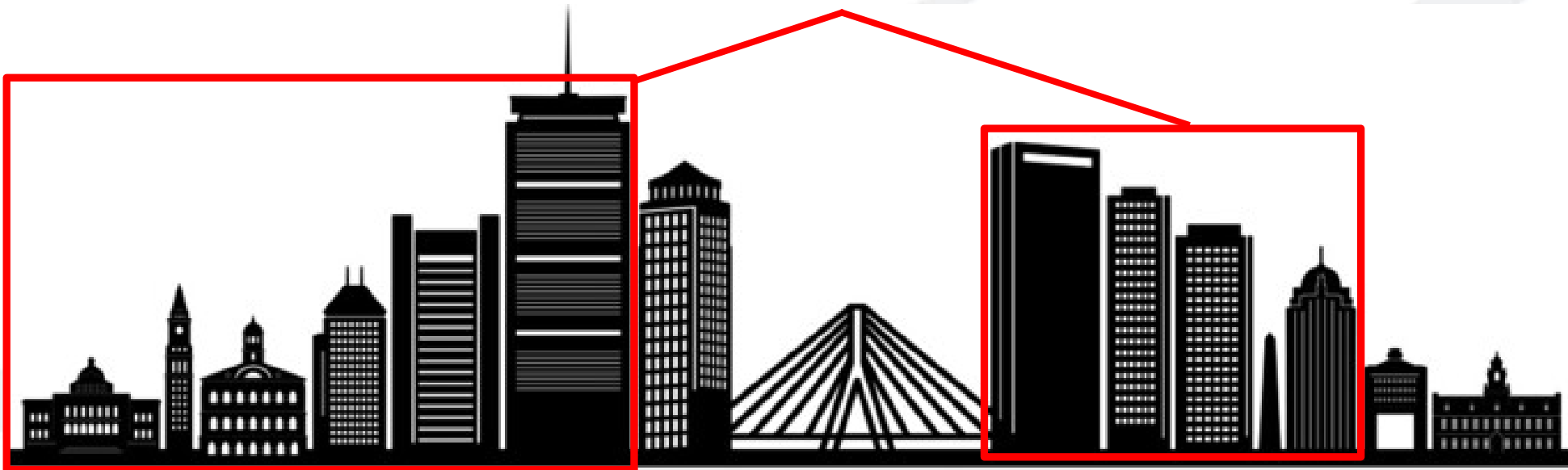

Circa 2050



Existing Buildings

We need solutions for decarbonizing our *existing* buildings.

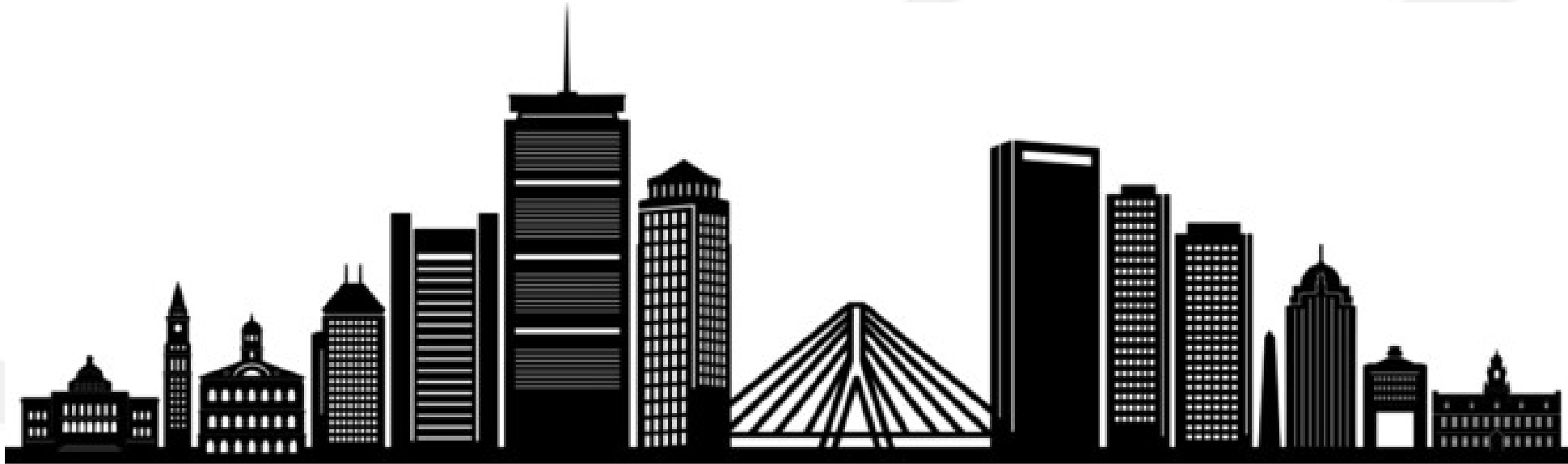

Ways to Electrify / Decarbonize Heating Systems

- **Electric boilers**

- Benefits: minimal equipment
- Challenges: large electrical requirements, COP = 1



- **Heat pumps**

- Benefits: higher-efficiency (COP = 2-2.5)
- Challenges: high upfront cost, more complexity, more space required



Ways to Electrify / Decarbonize

Can I get 180F HW with an ASHP?

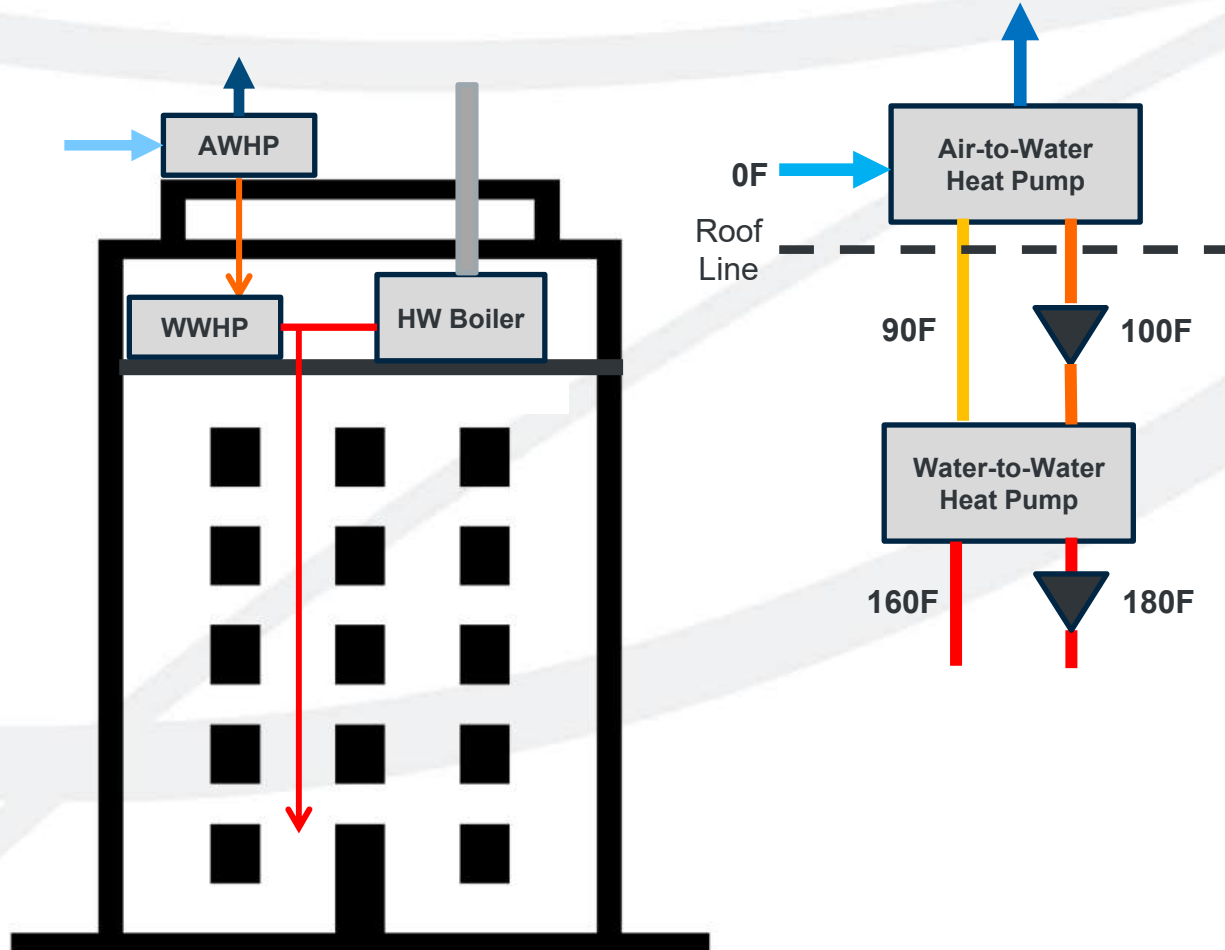

Ways to electrify / decarbonize

Does it make sense to make 180F HW with an ASHP?

There are caveats. We can't cheat physics.

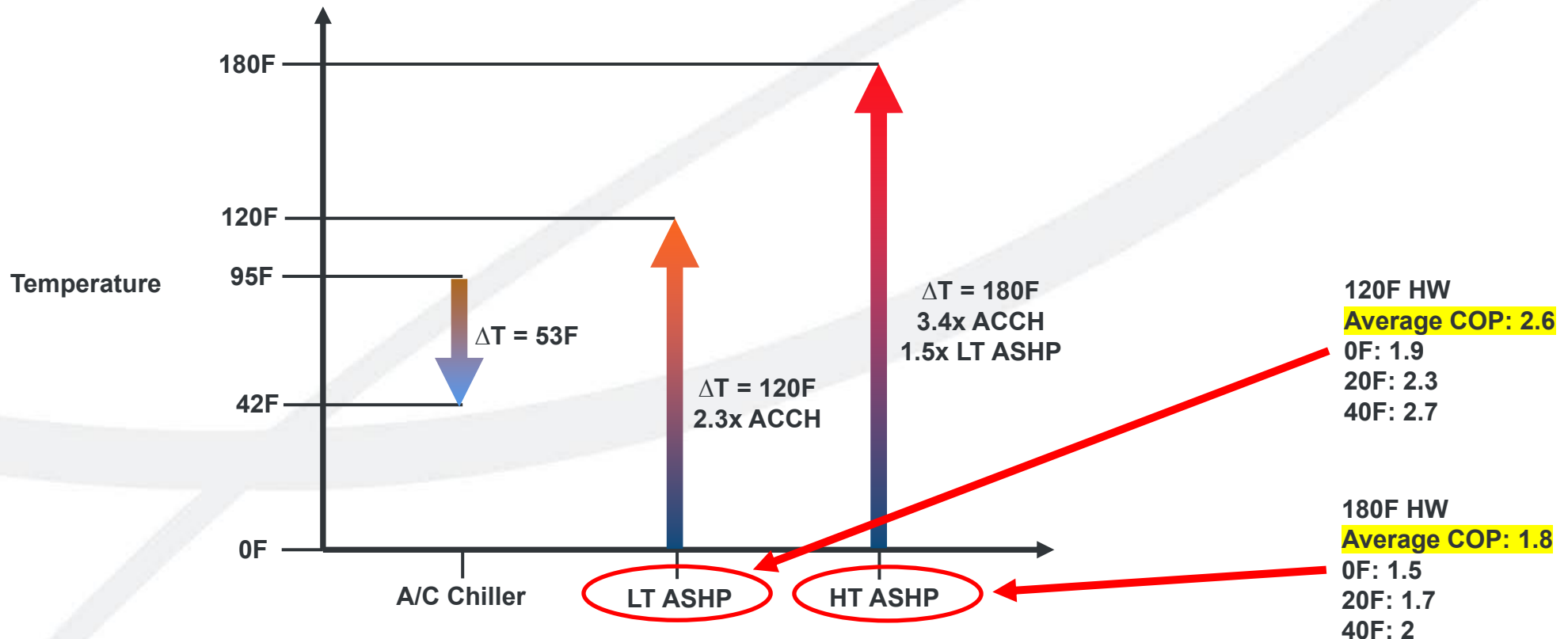

Where hydronic heating systems *can* be

Low-temp HW Heat pumps: COP = 2.5-3

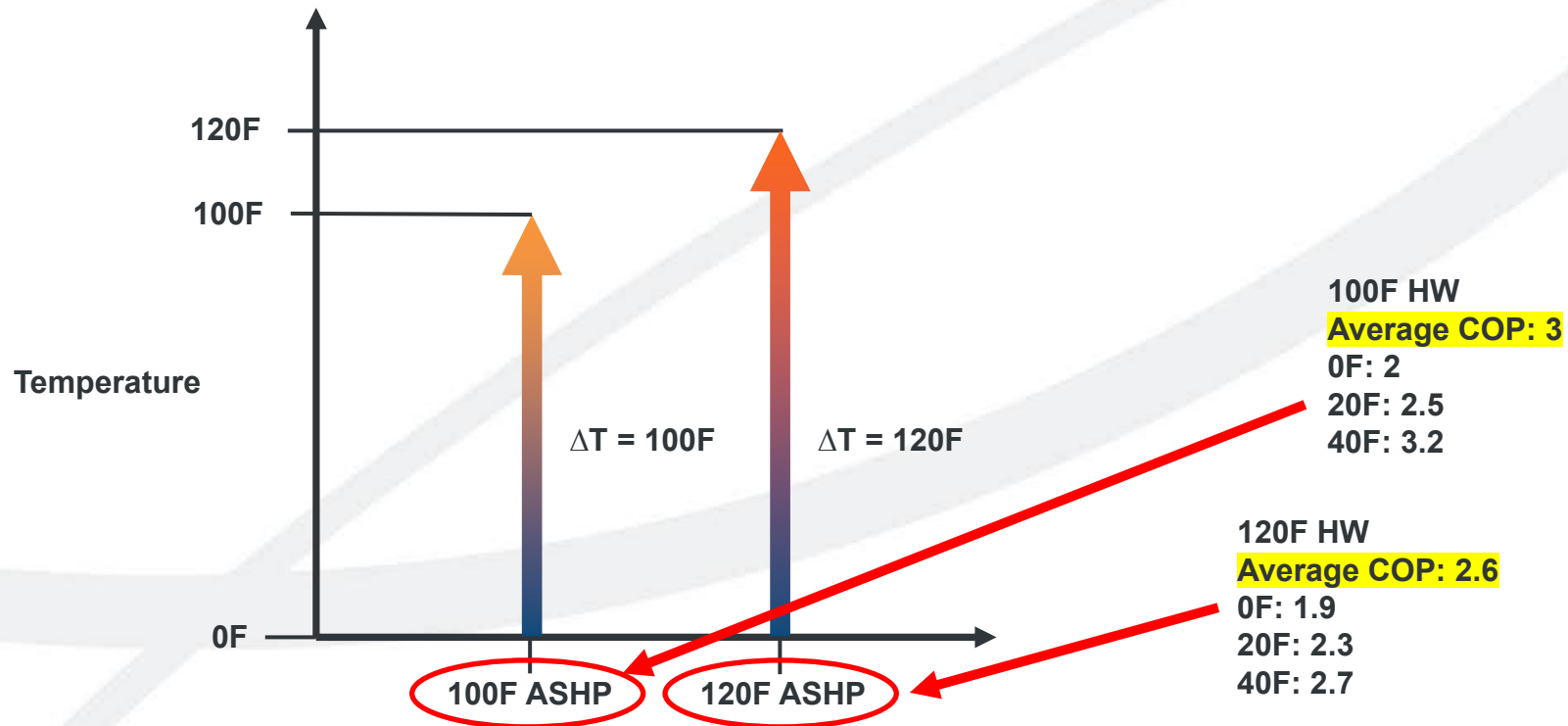

Water Temperature vs. Efficiency

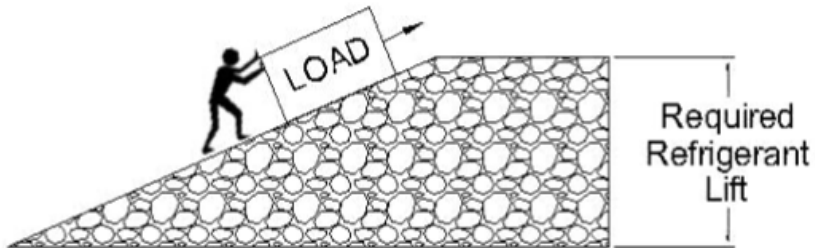
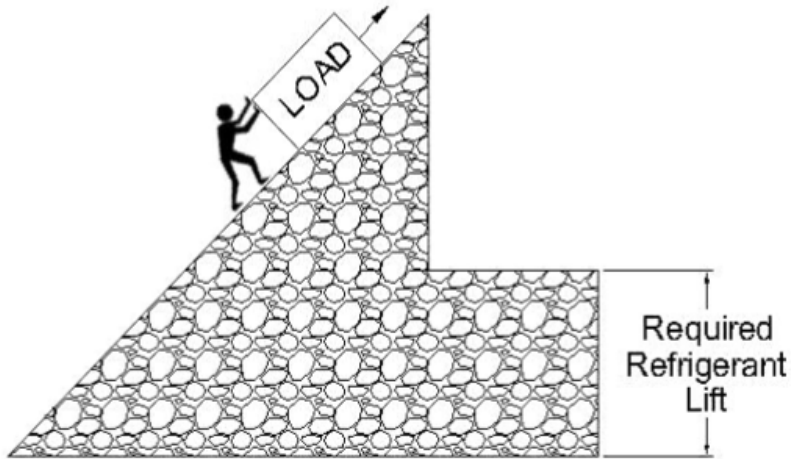

Only do as much lift as needed

At 40F ambient:

140F HW: COP = 2.17

130F HW: COP = 2.37

120F HW: COP = 2.60

110F HW: COP = 2.86

100F HW: COP = 3.15

16%
Energy
Savings

17%
Energy
Savings

31%
Energy
Savings

Lower temp = higher efficiency



Electrification Options – How Much Heat Pump?

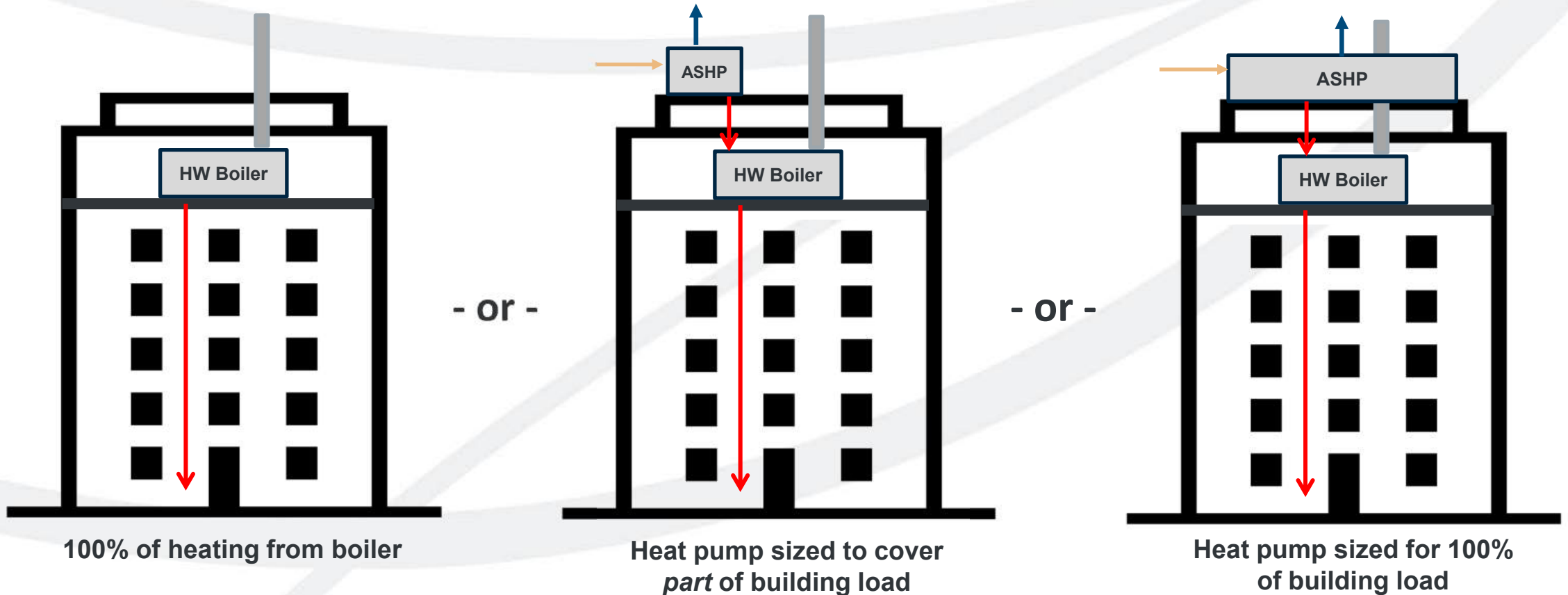

Building Heating – Air-to-Water Heat Pumps

Building Load vs. Heat Pump Capacity

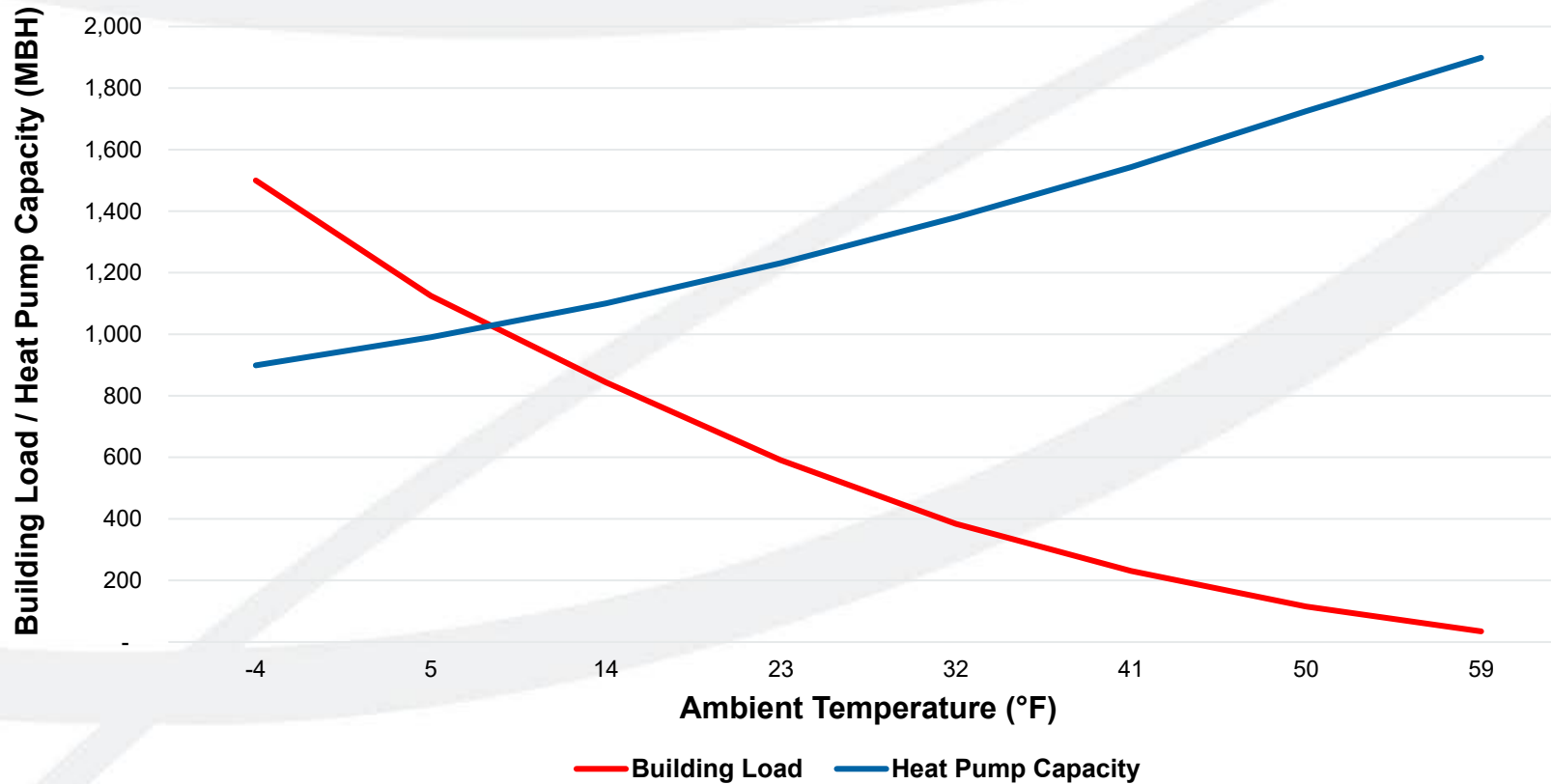

Building Heating – Air-to-Water Heat Pumps

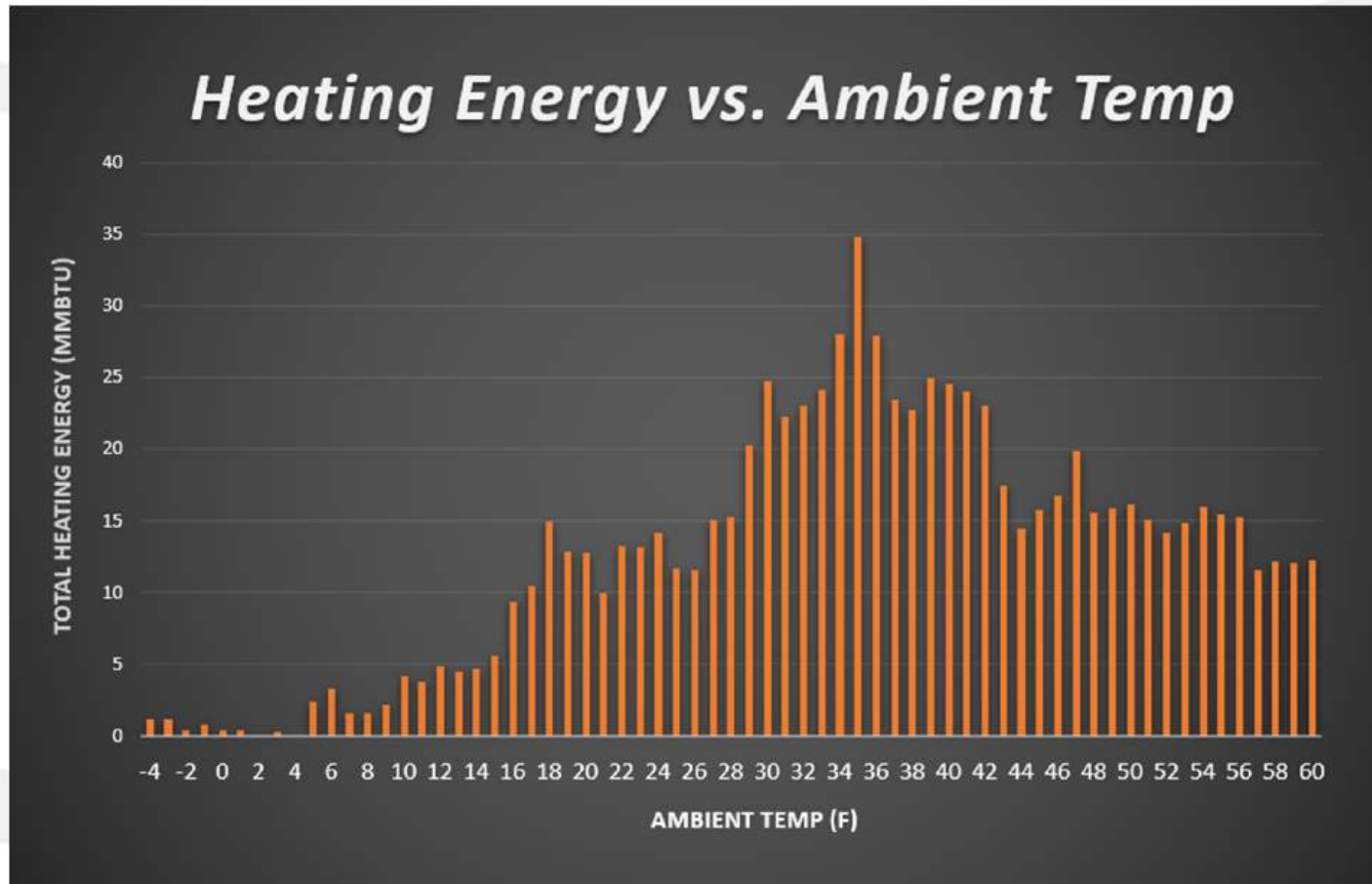

Building Heating – Air-to-Water Heat Pumps

What if we cover *part* of the load with ASHP's?

| % of Total Load Provided By Heat Pump at 0F | % Decarb |
|---|----------|
| 20% | 68.4% |

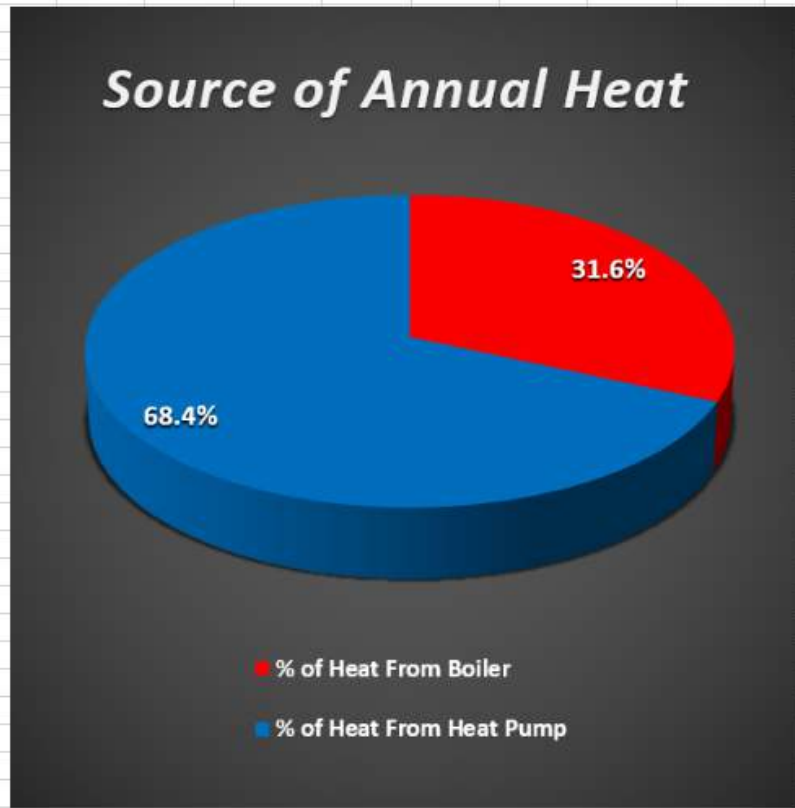
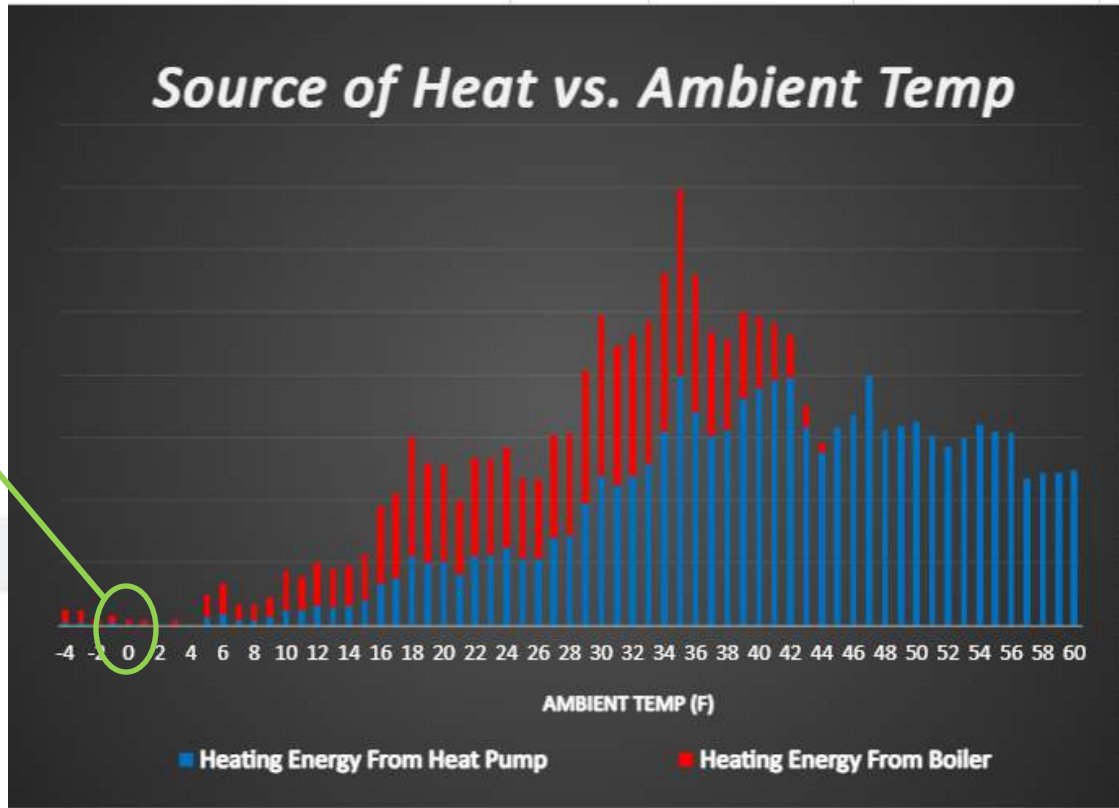
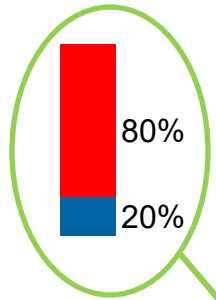

Building Heating – Air-to-Water Heat Pumps

What if we cover *part* of the load with ASHP's?

| % of Total Load Provided By Heat Pump at 0F | % Decarb |
|---|----------|
| 33% | 88.0% |

Source of Heat vs. Ambient Temp

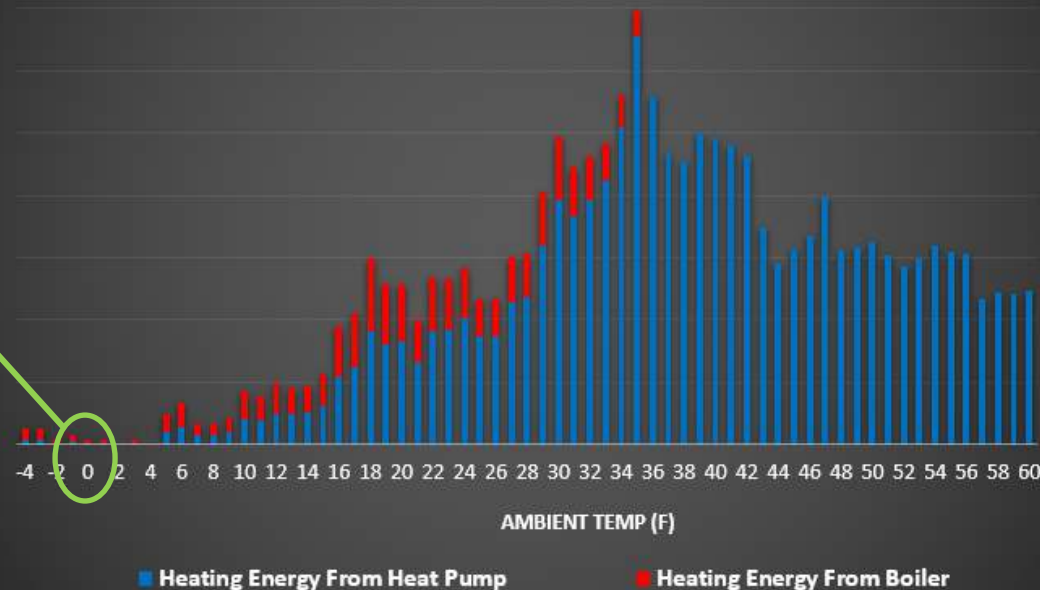

Source of Annual Heat

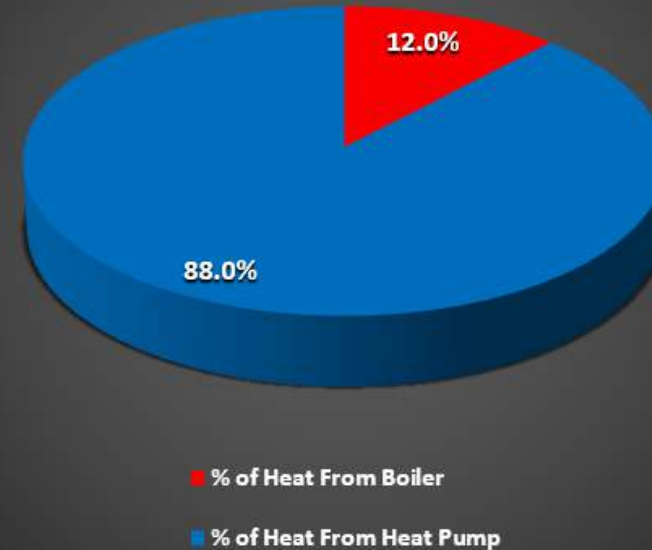

Building Heating – Air-to-Water Heat Pumps

What if we cover *part* of the load with ASHP's?

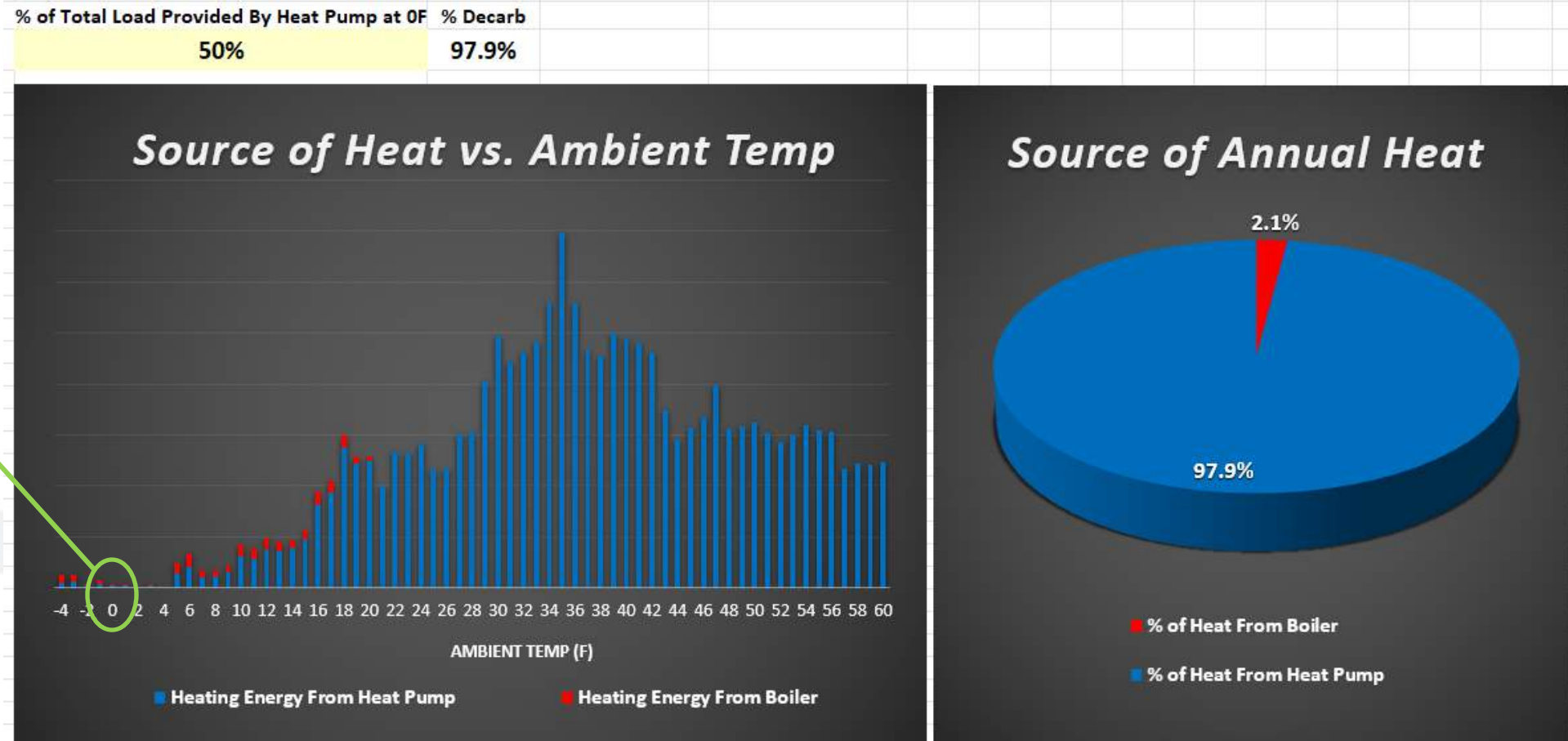

Building Heating – Air-to-Water Heat Pumps

What if we cover *part* of the load with ASHP's?

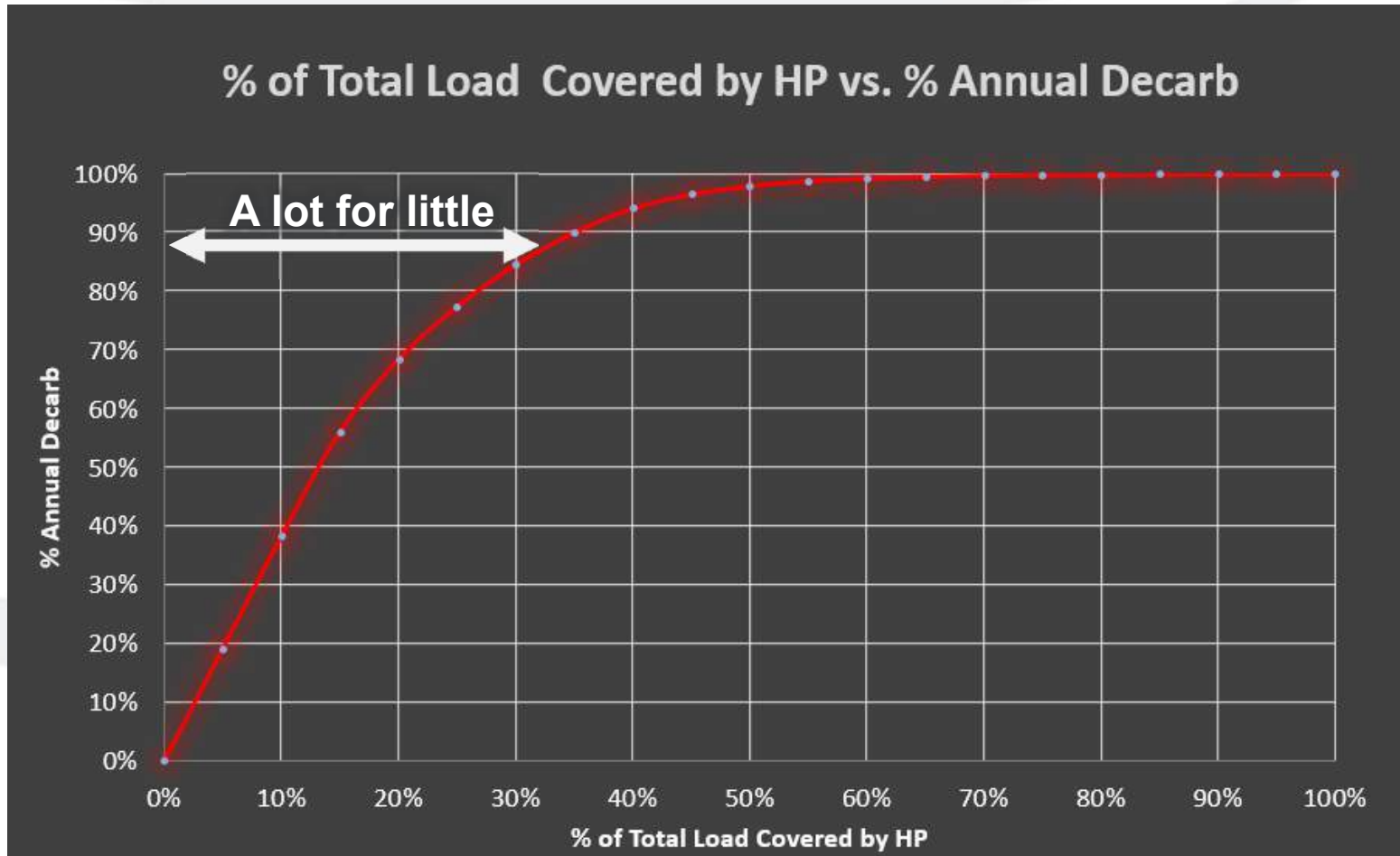

Capital Equipment vs. Value

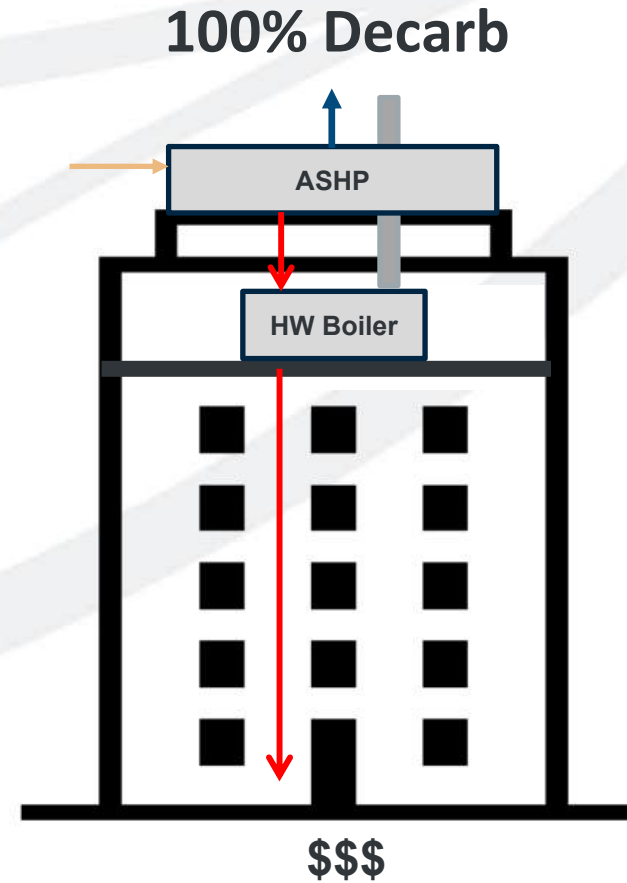
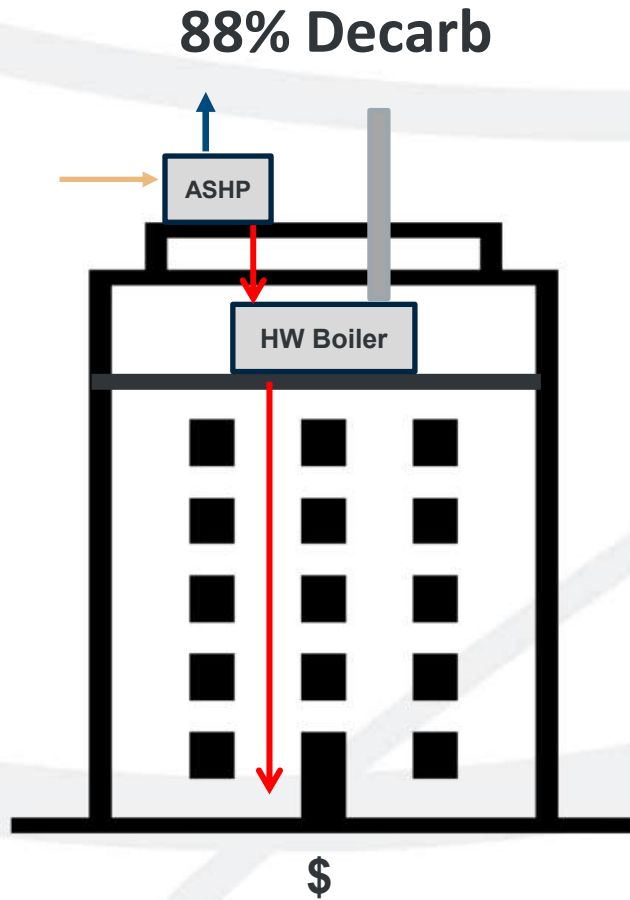

Capital Equipment vs. Value

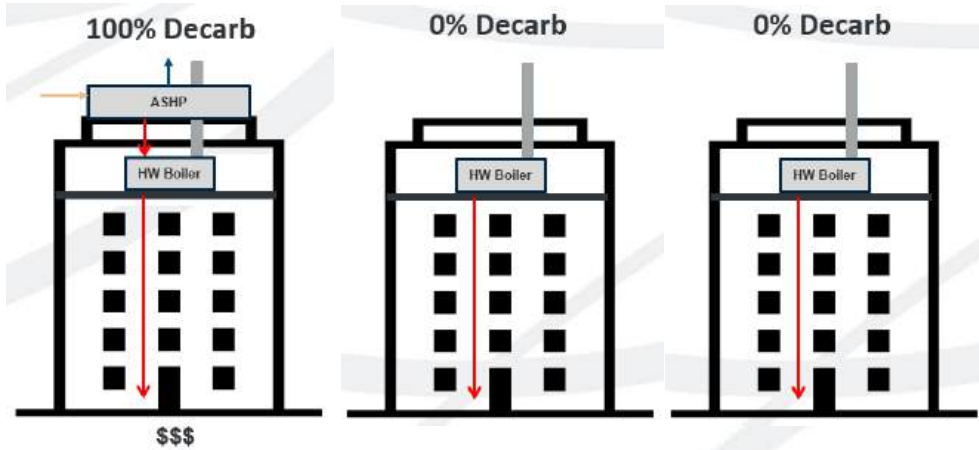

33% Total Decarb

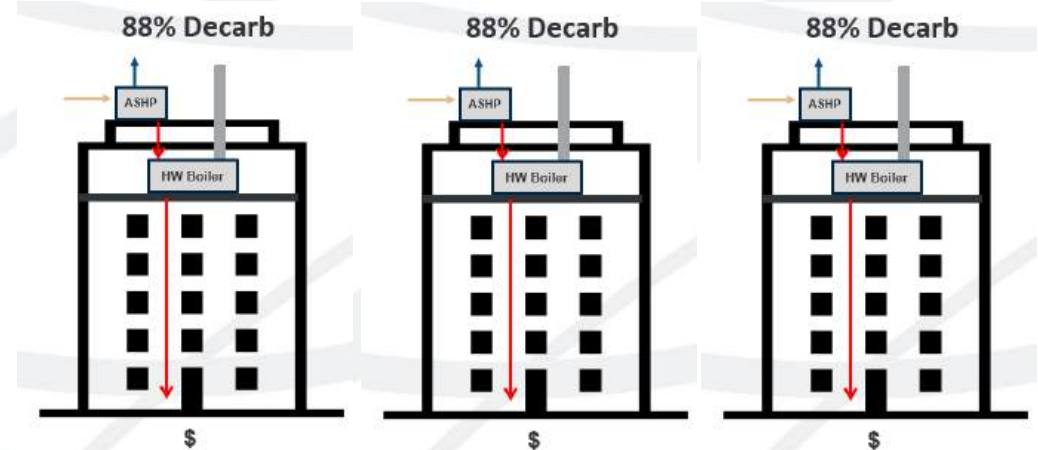

88% Total Decarb



Agenda

- Part 1 – Where are we going, why, and how do we get there?
- **Part 2 – Limitations of existing heating systems**
- Part 3 – Making the transition from high-temp to low-temp
- Part 4 – Deeper dive into low-temp HW terminal equipment



Limitations of existing heating equipment

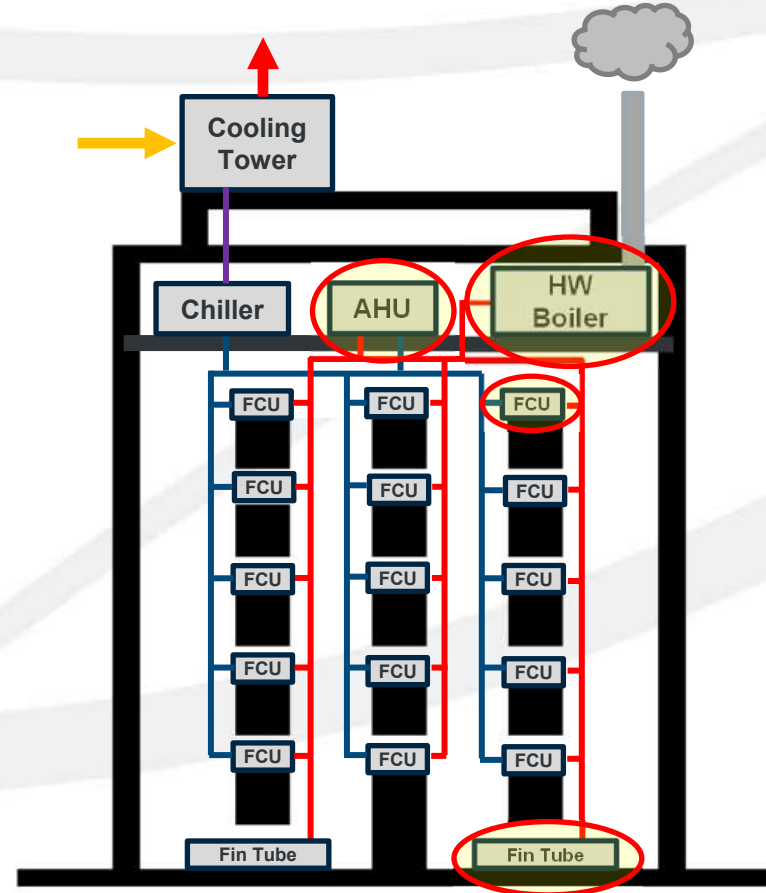

What if we...turn the setpoint temp to 120F?!

Existing equipment will not maintain original heat output

Heat flex Average is a function of average water temp - air temp

› $180/160 = 170\text{F} - 65\text{F} = 105\text{F}$

› $120/100 = 110\text{F} - 65\text{F} = 45\text{F}$

› $45 / 105 = 43\%$

Might maintain building when heating load is <40%



What if we...turn the setpoint temp to 120F?!

- **Non-condensing boilers become *condensing* boilers**
 - Condensation needs to be managed/collected/drained
 - Condensation is highly acidic
 - › Non-condensing boilers do not use corrosion-resistant materials (stainless steel)
 - › Non-condensing boiler chimneys are not designed for sustained condensation – especially not acidic condensation
 - This will promptly lead to significant damage, and ultimately, failure
 - **Need to keep return water >140F**



Limitations of existing heating equipment

Air Handling Unit Coils

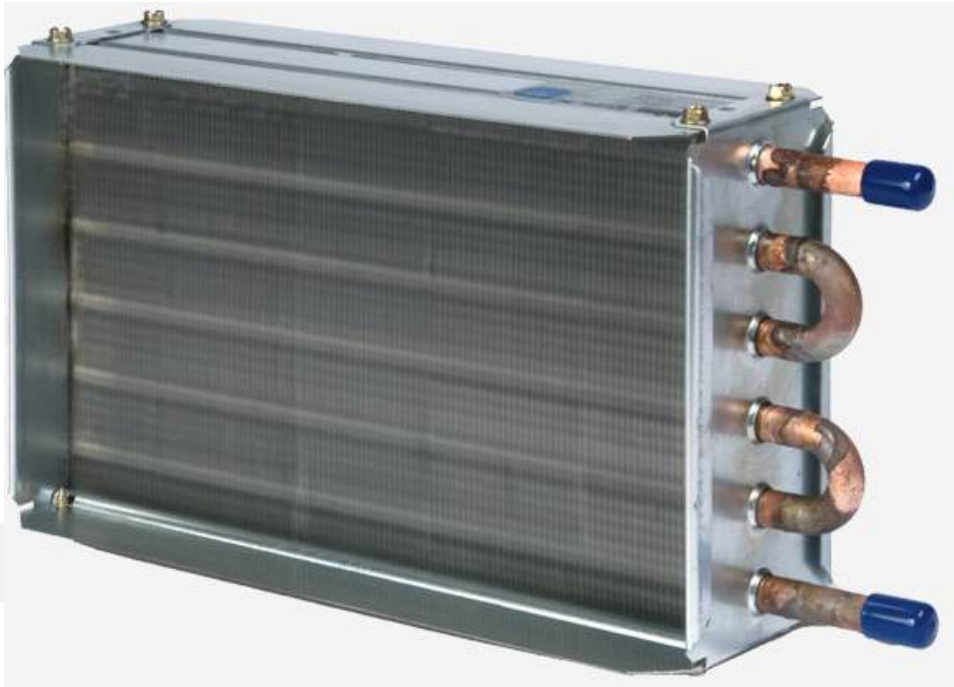

| Performance | | | | | |
|--------------------------------------|--------------------|---------------------------|------------------------------|-------------------------|---|
| Air Flow CFM | Altitude ft | | Face Area ft ² | Face Velocity ft/min | |
| 7500 | 0 | | 15.0 | 500.0 | |
| Total Capacity Btu/hr | Temperature | | | | Air Pressure Drop inH ₂ O |
| | Entering | | Leaving | | |
| | Air Dry Bulb °F | Water °F | Air Dry Bulb °F | Water °F | |
| 330236 | 45.0 | 180.0 | 85.3 | 160.0 | 0.12 |
| Pressure Drop ft H ₂ O | Flow rate gpm | Fluid Velocity ft/s | | Type | Volume gal |
| 13.8 | 32.8 | 5.8 | | Water | 3.00 |

| Performance | | | | | |
|--------------------------------------|--------------------|---------------------------|------------------------------|-------------------------|---|
| Air Flow CFM | Altitude ft | | Face Area ft ² | Face Velocity ft/min | |
| 7500 | 0 | | 15.0 | 500.0 | |
| Total Capacity Btu/hr | Temperature | | | | Air Pressure Drop inH ₂ O |
| | Entering | | Leaving | | |
| | Air Dry Bulb °F | Water °F | Air Dry Bulb °F | Water °F | |
| 180635 | 45.0 | 120.0 | 67.0 | 109.0 | 0.12 |
| Pressure Drop ft H ₂ O | Flow rate gpm | Fluid Velocity ft/s | | Type | Volume gal |
| 15.8 | 32.8 | 5.8 | | Water | 3.00 |

55% of original capacity

Limitations of existing heating equipment

Perimeter Fin Tube



| ELEMENT | WATER FLOW | PRESSURE DROP† | HOT WATER RATINGS BTU/HR. per linear ft. with 65°F entering air | | | | | | | | | | | | |
|--|------------|----------------|--|-------|-------|-------|-------|-------|-------|-------|-------|-------|-------|-------|-------|
| | | | 110°F | 120°F | 130°F | 140°F | 150°F | 160°F | 170°F | 180°F | 190°F | 200°F | 210°F | 215°F | 220°F |
| NO. 30-75 Baseboard with 3/4" E-75 element | 1 GPM | 47 | 160* | 210* | 260* | 320* | 380 | 450 | 510 | 580 | 640 | 710 | 770 | 810 | 840 |
| | 4 GPM | 525 | 160* | 220* | 270* | 340* | 400 | 480 | 540 | 610 | 680 | 750 | 810 | 860 | 890 |

https://www.slantfin.com/images/stories/Technical-Literature/ratings_fineline30_r.pdf?utm_source=chatgpt.com

31% of original capacity

Limitations of existing heating equipment

Fan Coil Units



| Hot Water Preheat Coil | | | | | |
|------------------------|--------------------------|---------------|-----------------------------------|------------------|-----------------------------------|
| Physical | | | | | |
| Fins per Inch | Number of Rows | Coil Circuits | Face Area | Face Velocity | Connections |
| 12 | 1 row, Standard Capacity | 1 | 1.3 ft ² | 461.5 ft/min | 1/2 inch Nominal Sweat (5/8 O.D.) |
| Performance | | | | | |
| Total Capacity Btu/hr | Air Dry Bulb | | Temperature | | |
| | Entering °F | Leaving °F | Entering °F | Fluid Leaving °F | |
| 20641 | 70.0 | 101.5 | 180.0 | 160.2 | |
| Fluid | | | | | |
| Type | Flow Rate gpm | | Pressure Drop ft H ₂ O | | Unit Handling |
| Water | 2.1 | | 11.81 | | Left Hand (Front of Face) |

| Hot Water Preheat Coil | | | | | |
|------------------------|--------------------------|---------------|-----------------------------------|------------------|-----------------------------------|
| Physical | | | | | |
| Fins per Inch | Number of Rows | Coil Circuits | Face Area | Face Velocity | Connections |
| 12 | 1 row, Standard Capacity | 1 | 1.3 ft ² | 461.5 ft/min | 1/2 inch Nominal Sweat (5/8 O.D.) |
| Performance | | | | | |
| Total Capacity Btu/hr | Air Dry Bulb | | Temperature | | |
| | Entering °F | Leaving °F | Entering °F | Fluid Leaving °F | |
| 9512 | 70.0 | 84.5 | 120.0 | 110.9 | |
| Fluid | | | | | |
| Type | Flow Rate gpm | | Pressure Drop ft H ₂ O | | Unit Handling |
| Water | 2.1 | | 11.56 | | Left Hand (Front of Face) |

46% of original capacity

Limitations of existing heating equipment

The existing boilers can't sustain with low temp HW

- and -

The existing terminal equipment can't cover load with lower temp HW



Agenda

- Part 1 – Where are we going, why, and how do we get there?
- Part 2 – Limitations of existing heating systems
- **Part 3 – Making the transition from high-temp to low-temp**
- Part 4 – Deeper dive into low-temp HW terminal equipment



Making the Transition

- 1. Replace terminal equipment with equipment rated for lower temp HW**
 - » Remove the *need* for 180F HW
- 2. Replace non-condensing boilers with condensing boilers**
 - » Provide proper venting for condensing boilers
- 3. Add heat pumps**
- 4. Integrate proper control strategy**



Transitioning in Stages

AHU Coils – Added Rows

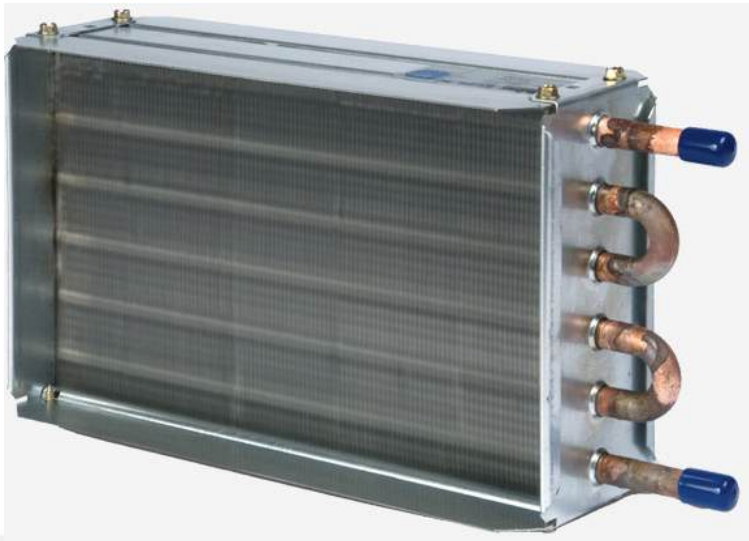

| Performance | | | | | | |
|--------------------------------------|--------------------|---------------------------|------------------------------|-------------------------|---|--|
| Air Flow CFM | Altitude ft | | Face Area ft ² | Face Velocity ft/min | | |
| 7500 | 0 | | 15.0 | 500.0 | | |
| Total Capacity Btu/hr | Temperature | | | | Air Pressure Drop inH ₂ O | |
| | Entering | | Air Dry Bulb °F | Leaving | | |
| | Air Dry Bulb °F | Water °F | | Water °F | | |
| 330236 | 45.0 | 180.0 | 85.3 | 160.0 | 0.12 | |
| Pressure Drop ft H ₂ O | Flow rate gpm | Fluid Velocity ft/s | | Type | Volume gal | |
| 13.8 | 32.8 | 5.8 | | Water | 3.00 | |

| Performance | | | | | | |
|--------------------------------------|--------------------|---------------------------|------------------------------|-------------------------|---|--|
| Air Flow CFM | Altitude ft | | Face Area ft ² | Face Velocity ft/min | | |
| 7500 | 0 | | 15.0 | 500.0 | | |
| Total Capacity Btu/hr | Temperature | | | | Air Pressure Drop inH ₂ O | |
| | Entering | | Air Dry Bulb °F | Leaving | | |
| | Air Dry Bulb °F | Water °F | | Water °F | | |
| 330761 | 45.0 | 120.0 | 85.3 | 99.8 | 0.16 | |
| Pressure Drop ft H ₂ O | Flow rate gpm | Fluid Velocity ft/s | | Type | Volume gal | |
| 4.7 | 32.8 | 2.9 | | Water | 7.00 | |

Increase coil rows. Maintain similar air pressure drop and water pressure drop

Transitioning in Stages

Fan Coil Units – Added Rows



| Hot Water Preheat Coil | | | | | |
|--------------------------|--------------------------|--------------------------------------|---------------------------|---------------|-----------------------------------|
| Physical | | | | | |
| Fins per Inch | Number of Rows | Coil Circuits | Face Area | Face Velocity | Connections |
| 12 | 1 row, Standard Capacity | 1 | 1.3 ft ² | 461.5 ft/min | 1/2 inch Nominal Sweat (5/8 O.D.) |
| Performance | | | | | |
| Total Capacity Btu/hr | Temperature | | | | |
| | Air Dry Bulb | | Fluid | | |
| | Entering °F | Leaving °F | Entering °F | Leaving °F | |
| 20641 | 70.0 | 101.5 | 180.0 | 160.2 | |
| Fluid | | | | | |
| Type | Flow Rate gpm | Pressure Drop ft H ₂ O | Unit Handling | | |
| Water | 2.1 | 11.81 | Left Hand (Front of Face) | | |

| Hot Water Coil | | | | | |
|--------------------------|------------------|--------------------------------------|---------------------------|-----------------------------------|--|
| Physical | | | | | |
| Fins per Inch | Number of Rows | Coil Circuits | Face Area | Connections | |
| 12 | 3 | 4 | 2.1 ft ² | 1/2 inch Nominal Sweat (5/8 O.D.) | |
| Performance | | | | | |
| Total Capacity Btu/hr | Temperature | | | | |
| | Air | | Fluid | | |
| | Entering °F | Leaving °F | Entering °F | Leaving °F | |
| 23755 | 70.0 | 106.2 | 120.0 | 100.0 | |
| Fluid | | | | | |
| Type | Flow rate gpm | Pressure Drop ft H ₂ O | Unit Handling | | |
| Water | 2.4 | 1.72 | Left Hand (Front of Face) | | |

Transitioning in Stages

Multi-pass low-temp fin tube (with fan assist)



BTU/ft at 65F EAT

| Height (in) | Rows | C/C (in) | Steam (1 psi 215°F) | Average Water Temperature (°F) | | | | | | | |
|-------------|------|----------|---------------------|--------------------------------|------|------|------|------|------|-----|-----|
| | | | | 210 | 200 | 190 | 180 | 170 | 160 | 150 | 140 |
| 12 | 1 | - | 1964 | 1866 | 1689 | 1532 | 1355 | 1198 | 1041 | 884 | 786 |



| Passes | Height/Depth | Width | 120/100/65° |
|--------|--------------|-----------|----------------|
| # | H in inch | D in inch | BTU/h per foot |
| 8 | 14 | 8.6 | 840 |

w/out fan assist

| Passes | Height/Depth | Width | 120/100/65° |
|--------|--------------|-----------|-------------|
| # | H in inch | D in inch | BTU/h per |
| 8 | 14 | 8.6 | 1273 |

w/ fan assist

Making the Transition

Replace non-condensing Boilers with *Condensing* Boilers

- › Opportunity to right-size?
 - » Has the building been tested for how much boiler capacity is actually used?
 - » Are there logs of boiler capacity over time?
- › Replace existing chimney / draft venting systems with proper venting systems designed for condensing boilers, inclusive of condensate management
- › Optimize boiler operation strategy to maximize efficiency. Often available from boiler manufacturer controls.



Making the Transition

Heat recovery on 4-pipe systems

- › Energy savings on shoulder days
- › Reduced peak heating load if there are year-round cooling loads

SIMULTANEOUS HEATING AND COOLING

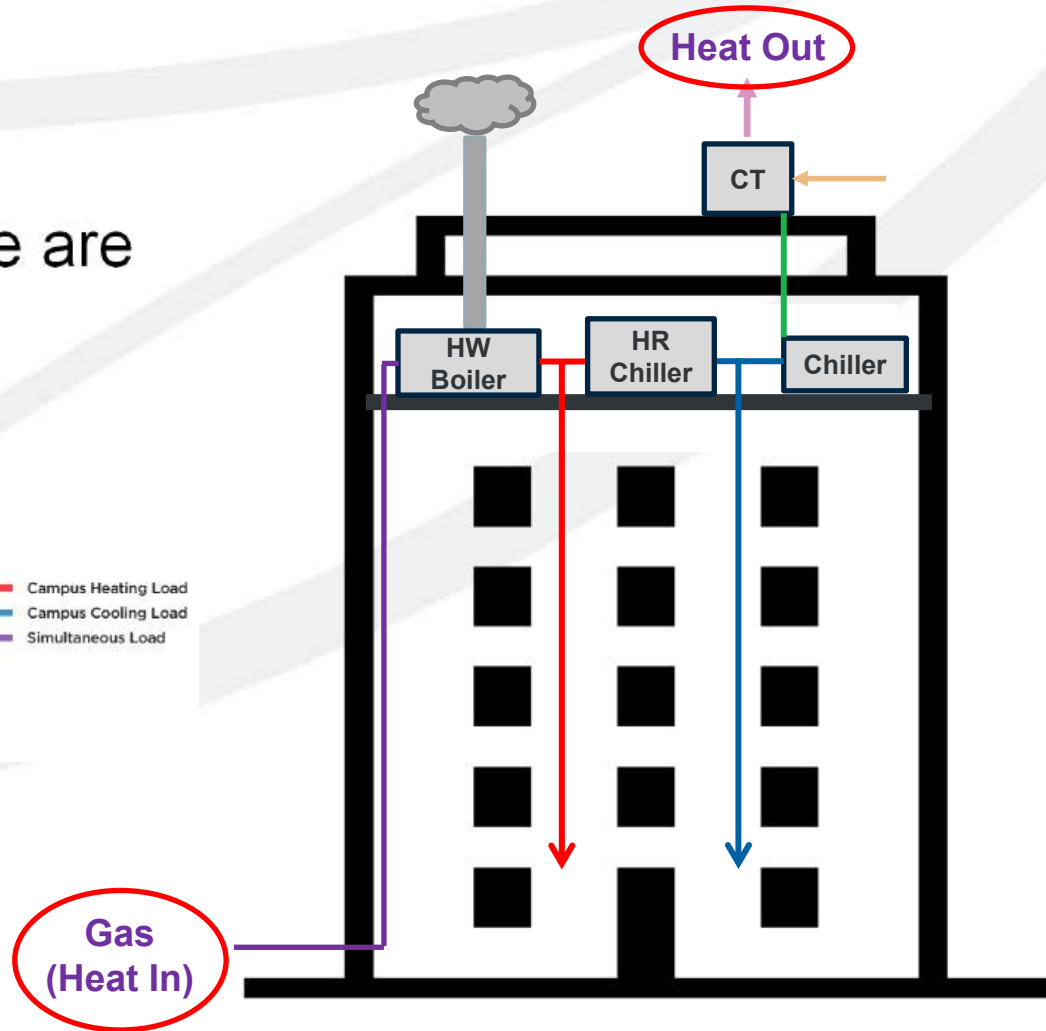
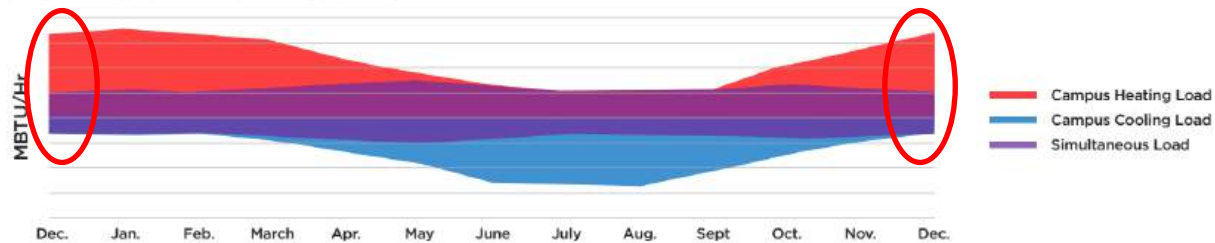

Making the Transition

Add heat pumps

- › Find the right value for heat pump capacity vs. boiler offset
- › What's the goal?
 - » Minimum carbon impact? Lowest annual operating cost?
These two might result in different strategies

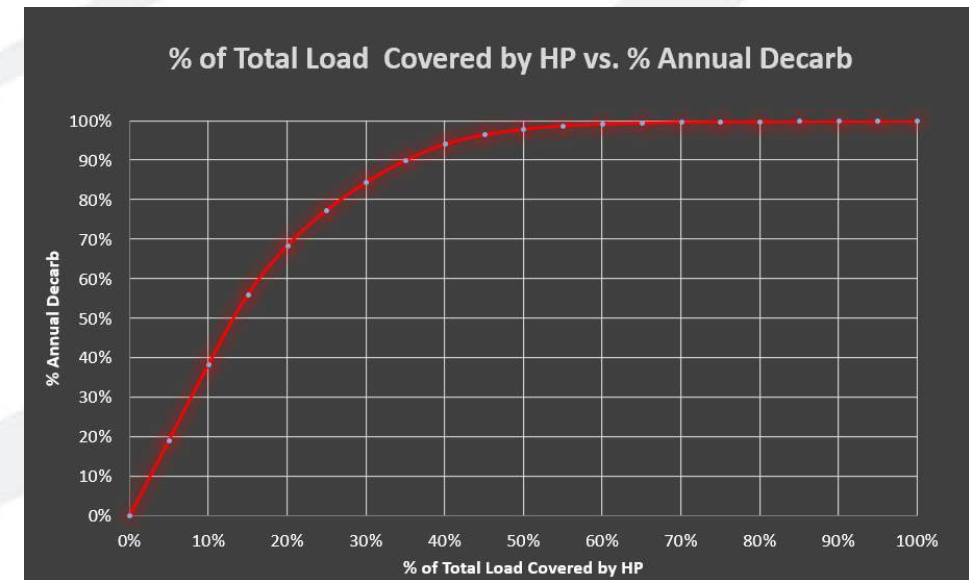

Making the Transition

Add heat pumps

- › Requires additional pumps and heat exchangers due to glycol in air-to-water heat pumps

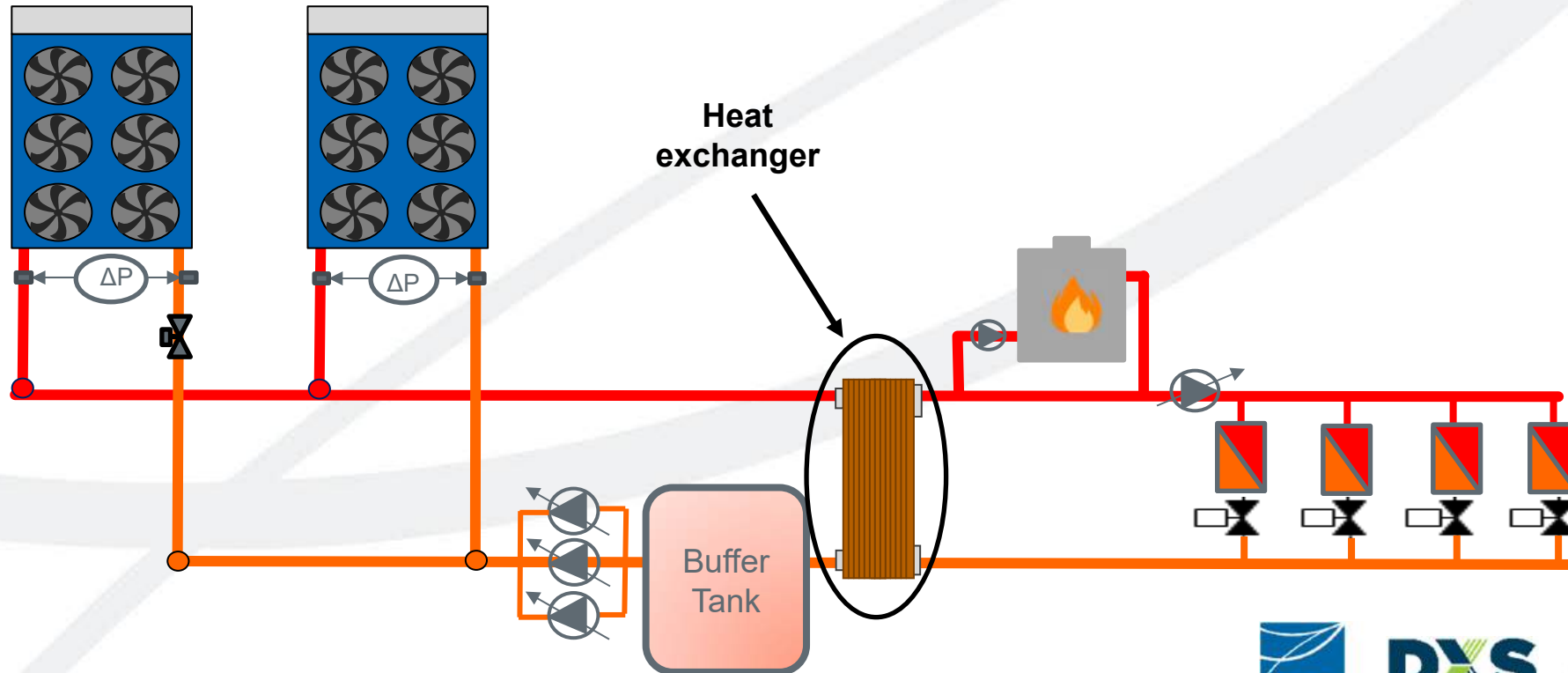

Making the Transition

Integrate proper control strategy

- › Find efficiencies for hybrid heating plant
 - » Variable ambient lockout temp based on utility costs
 - » HW temp reset for efficiency increase
 - » Plant optimization (mindful of pump energy)

At 40F ambient

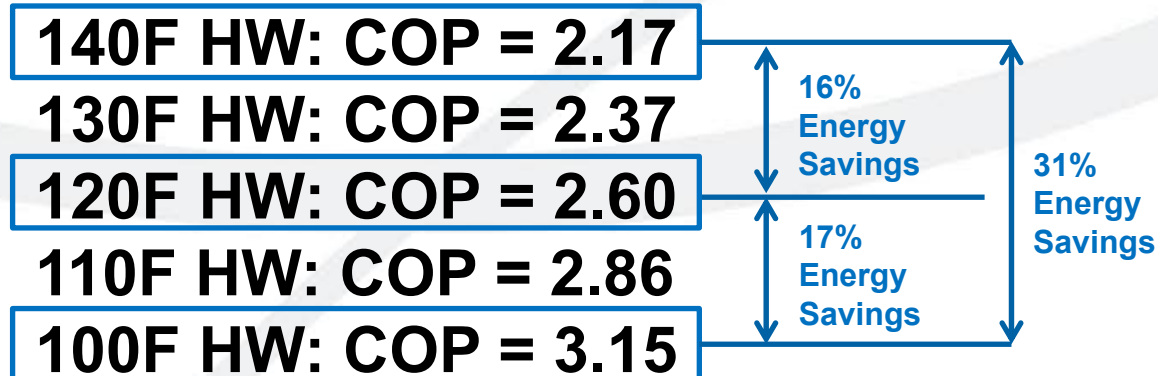

Agenda

- Part 1 – Where are we going, why, and how do we get there?
- Part 2 – Limitations of existing heating systems
- Part 3 – Making the transition from high-temp to low-temp
- **Part 4 – Deeper dive into low-temp HW terminal equipment**



Low-Temperature Hydronic Heating Applications

Jaga is a Belgian manufacturer that specializes in hydronic heating and cooling solutions with a specific focus on the use of low-temperature hot water heating (and higher temperature chilled water cooling).



jaga
CLIMATE
DESIGNERS



Improved Finned Tube Element

- Ideal for hydronic systems operating at 120°F or below
- Corrugated (enhanced) fins
- Can be used with or without fan assist
- Tubes are engineered to maintain turbulent flow as low as 0.15 GPM, giving application flexibility
- Proprietary anti-static coating for sustained performance



Finned Tube – Fan Assist v.s. No Fan

Without Fan Assist

| Group | Model | Height/Depth | Length | Type | Width | 120/100/65° | | | Water side pressure drop ftH2O |
|-----------------|-----------------|--------------|-----------|------|-----------|------------------|----------------|-------------|--------------------------------|
| | | H in inch | L in inch | | D in inch | Heating in BTU/h | BTU/h per foot | Flow in GPM | |
| Horizontal Wall | Strada Continuo | 14 | 23.5 | 10 | 4.8 | 797 | 405 | 0.08 | 0.0006 |

With Fan Assist

| Group | Model | Height/Depth | Length | Type | Width | 120/100/65° | | | Water side pressure drop ftH2O |
|-----------------|-----------------|--------------|-----------|------|-----------|------------------|----------------|-------------|--------------------------------|
| | | H in inch | L in inch | | D in inch | Heating in BTU/h | BTU/h per foot | Flow in GPM | |
| Horizontal Wall | Strada Continuo | 14 | 23.5 | 10 | 4.8 | 1155 | 590 | 0.12 | 0.0008 |

Approximate Increase of 45%



Deeper Look into Fan Assist

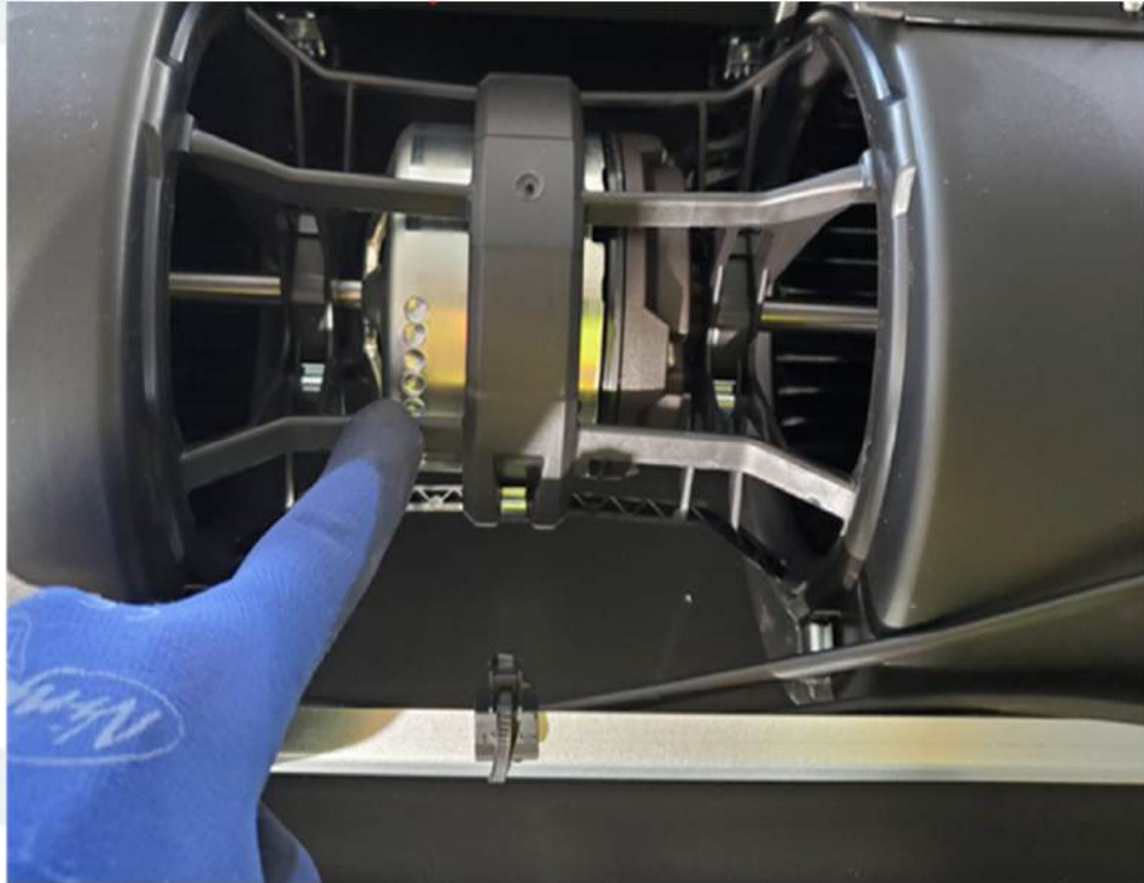

Multi-Pass Convectors vs. Legacy Radiators

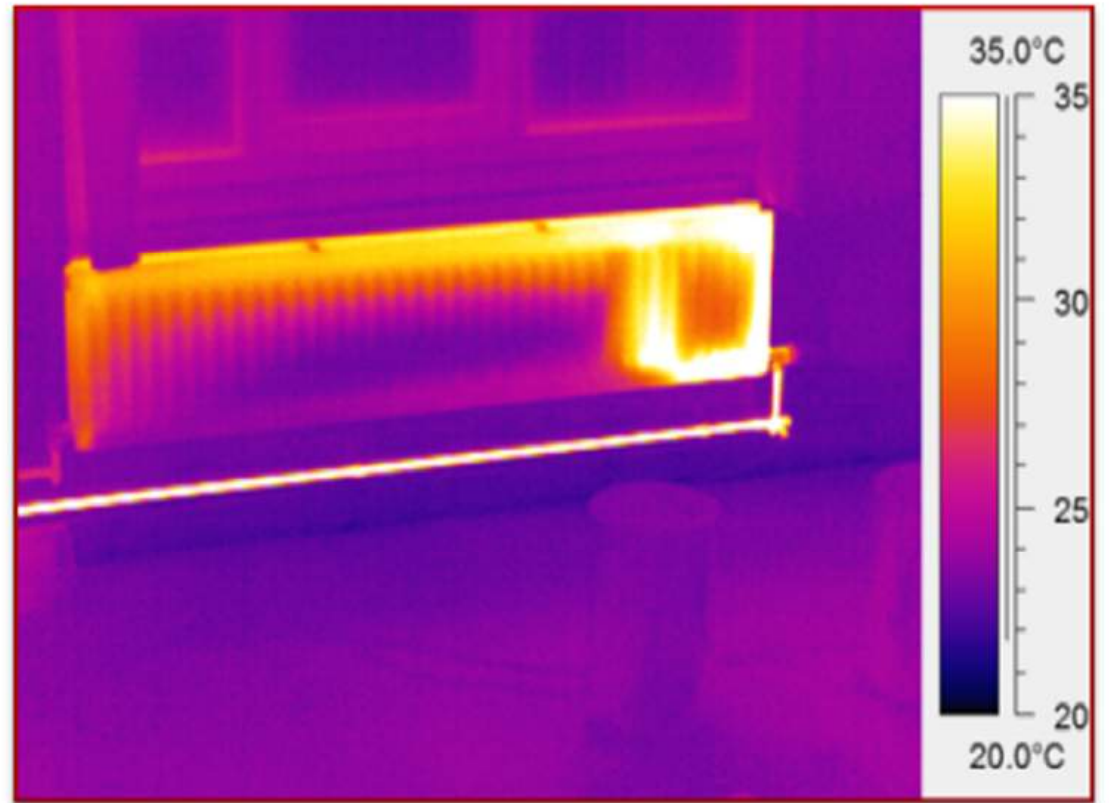
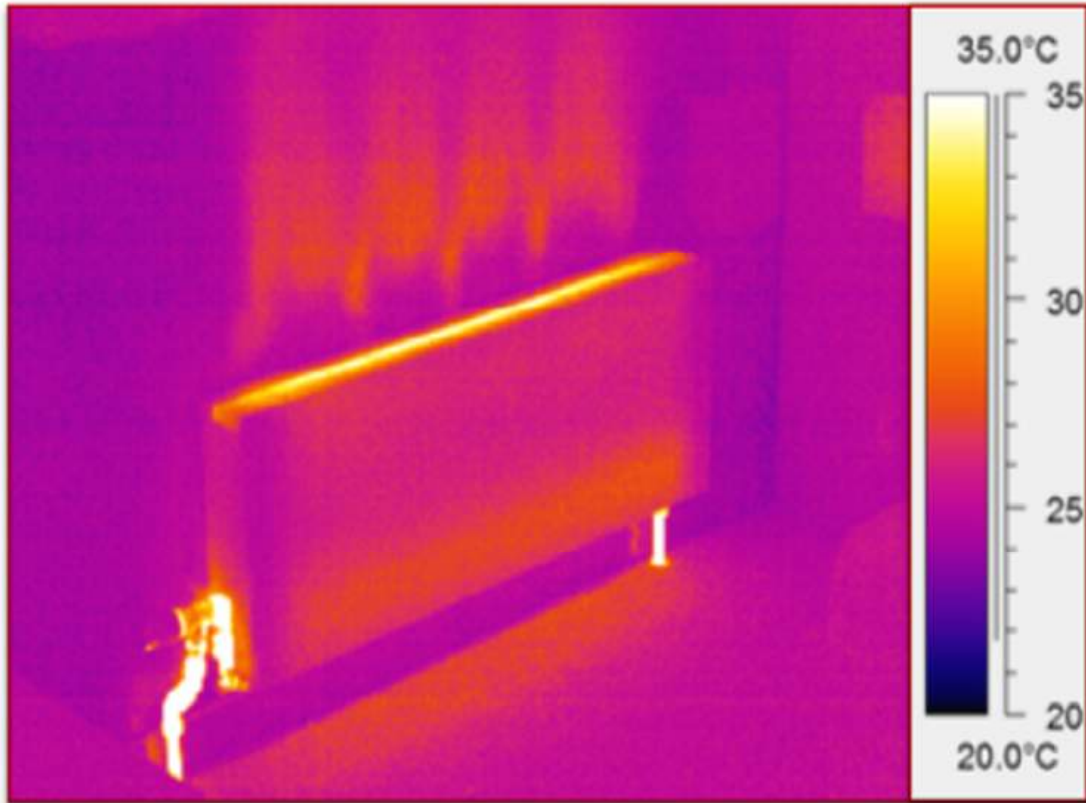

Unit Heater – Venturi Effect

TRADITIONAL UNIT HEATERS



JAGA UNIT HEATER WITH AVS

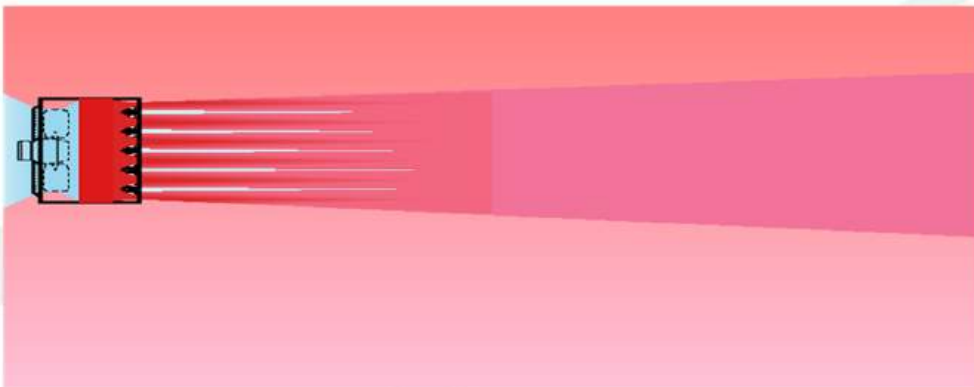

Briza Fan Coil Unit

Low Voltage, Ultra Thin FCU

Depth 4 ½" – 6 ¾"



Traditional line voltage, compact FCU

Depth 8 ¾" – 10 "

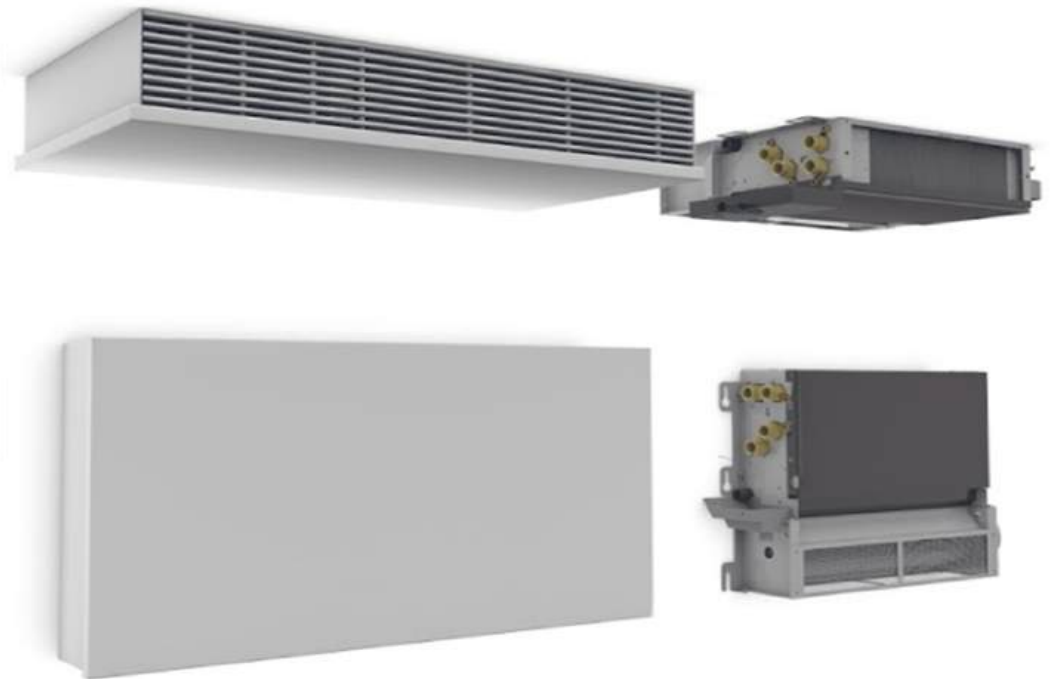

Terminal Heating Types

Continuo



Free-Standing



Knock-On-Wood

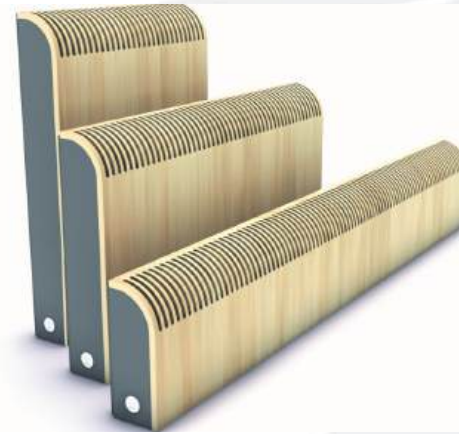

Clima Canal



Tempo



Vertiga



Build-in-Wall



Induction

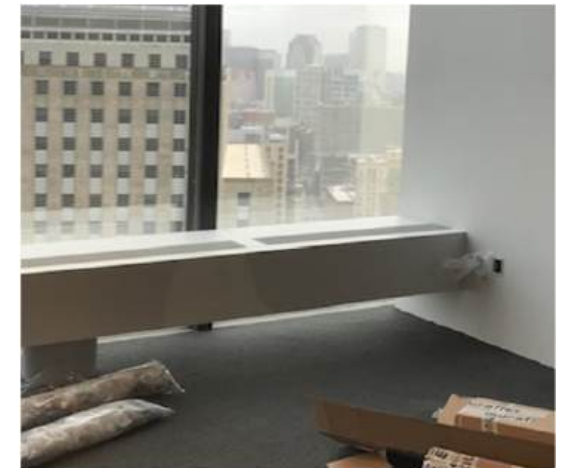

What we discussed today

- **Decarbonizing and reducing energy in existing buildings requires the use of lower temperature hot water**
- **Integration of new equipment is required to do this**
- **There are steps that can be followed to do this**
 - Remove the *need* for 180F hot water
 - Provide central equipment can efficiently provide low-temp HW
 - Create the proper control strategy to optimize performance and operating cost
- **Heating products exist to facilitate this transition**



Thank you



Doug Andrade
Doug.Andrade@hts.com

Mark LaFrance
Mark.LaFrance@hts.com